

SERVICE MANUAL

STANDARD INVERTER PACKAGED AIR CONDITIONERS (Split system, Air to air heat pump type)

CEILING CASSETTE-4 WAY COMPACT TYPE

Single type

FDTC40ZIXVD
50ZIXVD
60ZIXVD

Twin type

FDTC71VNPVD
100VNPVD
100VSPVD
125VNPVD
125VSPVD

Triple type

FDTC140VNTVD
140VSTVD

Double-Twin type

FDTC200VSDVD
FDTC250VSDVD

CEILING SUSPENDED TYPE

Single type

FDEN40ZIXVD
50ZIXVD
60ZIXVD
71VNVD
100VNVD
100VSVD
125VNVD
125VSVD
140VNVD
140VSVD

Twin type

FDEN71VNPVD
100VNPVD
100VSPVD
125VNPVD
125VSPVD
140VNPVD
140VSPVD
200VSPVD
250VSPVD

Triple type

FDEN140VNTVD
140VSTVD
200VSTVD

DUCT CONNECTED-HIGH STATIC PRESSURE TYPE

Single type

FDU71VNVD
100VNVD
100VSVD
125VNVD
125VSVDFDU140VNVD
140VSVD
200VSVD
250VSVD

V Multi System

(OUTDOOR UNIT)

FDC71VN FDC140VN
100VN 140VS
100VS 200VS
125VN 250VS
125VS

(INDOOR UNIT)

FDT40VD FDEN40VD
50VD 50VD
60VD 60VD
71VD 71VD
100VD 100VD
125VD 125VD

CEILING CASSETTE-4 WAY TYPE

Single type

FDT40ZIXVD
50ZIXVD
60ZIXVD
71VNVD
100VNVD
100VSVD
125VNVD
125VSVD
140VNVD
140VSVD

Twin type

FDT71VNPVD
100VNPVD
100VSPVD
125VNPVD
125VSPVD
140VNPVD
140VSPVD
200VSPVD
250VSPVD

Triple type

FDT140VNTVD
140VSTVD
200VSTVD

Double-Twin type

FDT200VSDVD
250VSDVD

DUCT CONNECTED-LOW/MIDDLE STATIC PRESSURE TYPE

Single type

FDUM50ZIXVD
60ZIXVD
71VNVD
100VNVD
100VSVD
125VNVD
125VSVD
140VNVD
140VSVD

Twin type

FDUM100VNPVD
100VSPVD
125VNPVD
125VSPVD
140VNPVD
140VSPVD
200VSPVD
250VSPVD

Triple type

FDUM140VNTVD
140VSTVD
200VSTVD

MITSUBISHI HEAVY INDUSTRIES, LTD.



Большая библиотека технической документации
<http://splitoff.ru/tehn-doc.html>
каталоги, инструкции, сервисные мануалы, схемы.

CONTENTS

1. OUTLINE OF OPERATION CONTROL BY MICROCOMPUTER	3
(1) Remote controller	3
(2) Operation control function by the wired remote controller	5
(3) Operation control function by the indoor controller	6
(4) Operation control function by the outdoor controller	16
(I) SRC40~60 models	16
(II) FDC71~250 models	20
2. MAINTENANCE DATA	31
2.1 Diagnosing of microcomputer circuit	31
(1) Selfdiagnosis function	31
(2) Troubleshooting procedure	35
(3) Troubleshooting at the indoor unit	35
(4) Troubleshooting at the outdoor unit	41
(5) Check of anomalous operation data with the remote controller	51
(6) Inspection display of wireless specification model (FDEN,FDT)	52
(7) Power transistor module (including the driver PCB) inspection procedure	53
(8) Inverter checker for diagnosis of inverter output	54
(9) Outdoor unit controller failure diagnosis circuit diagram	55
2.2 Troubleshooting flow	60
3. ELECTRICAL WIRING	119
(1) Indoor units	119
(2) Outdoor units	128
4. PIPING SYSTEM	133
5. APPLICATION DATA	140
(1) Installation of indoor unit	140
(a) Ceiling cassette-4way compact type (FDTC)	140
(b) Ceiling cassette-4way type (FDT)	146
(c) Ceiling suspended type (FDEN)	152
(d) Duct connected-Low / Middle static pressure type (FDUM)	156
(e) Duct connected-High static pressure type (FDU)	160
1) Models FDU71~140	160
2) Models FDU200,250	164

(2) Installation manual for wired remote controller **168**

(3) Installation of outdoor unit **172**

 (a) Models SRC40~60ZIX-S **172**

 (b) Model FDC71VN **179**

 (c) Models FDC100~140VN, 100~140VS **186**

 (d) Models FDC200,250VS **194**

 (e) Method for connecting the accessory pipe (Models FDC200,250 only) **201**

(4) Electric wiring work installation **203**

How to read the model name

Example: **FDTC 40 Z IXVD**

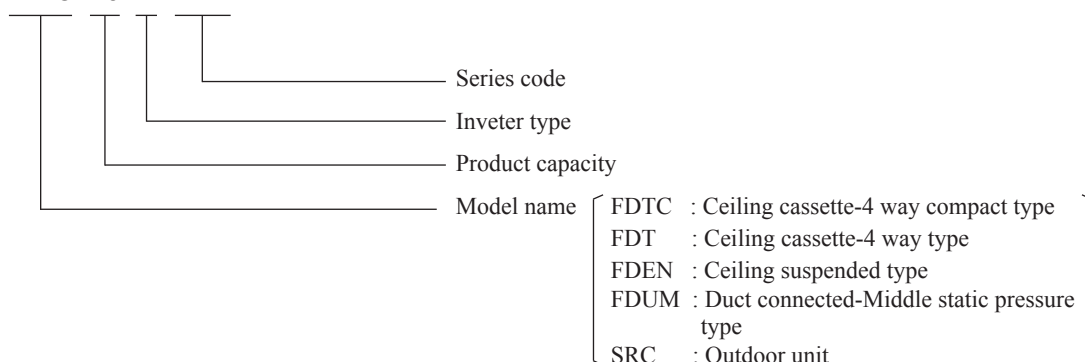

Example: **FDTC 100 VN P VD**

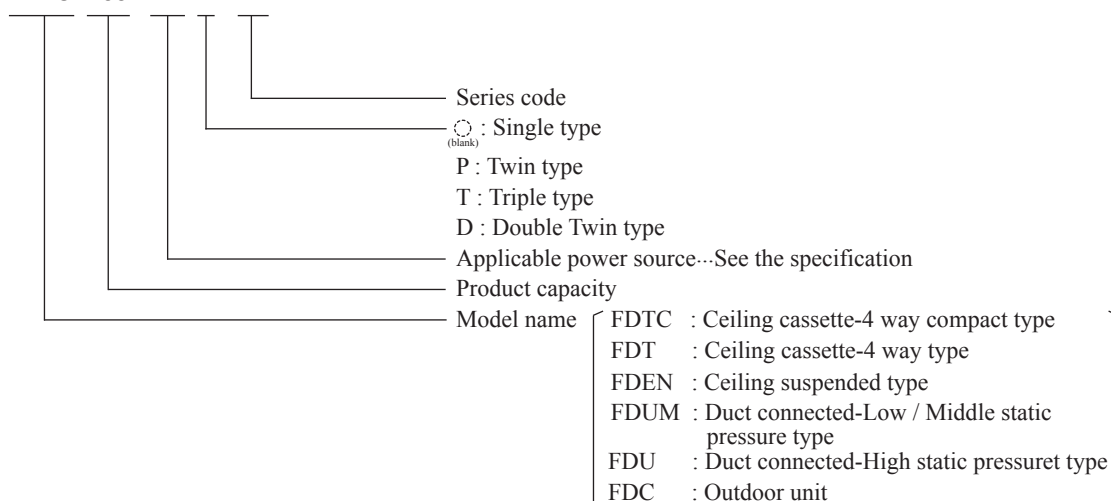

1. OUTLINE OF OPERATION CONTROL BY MICROCOMPUTER

(1) Remote controller

(a) Wired remote controller

The figure below shows the remote controller with the cover opened. Note that all the items that may be displayed in the liquid crystal display area are shown in the figure for the sake of explanation

Characters displayed with dots in the liquid crystal display area are abbreviated.

The figure below shows the remote control with the cover opened.

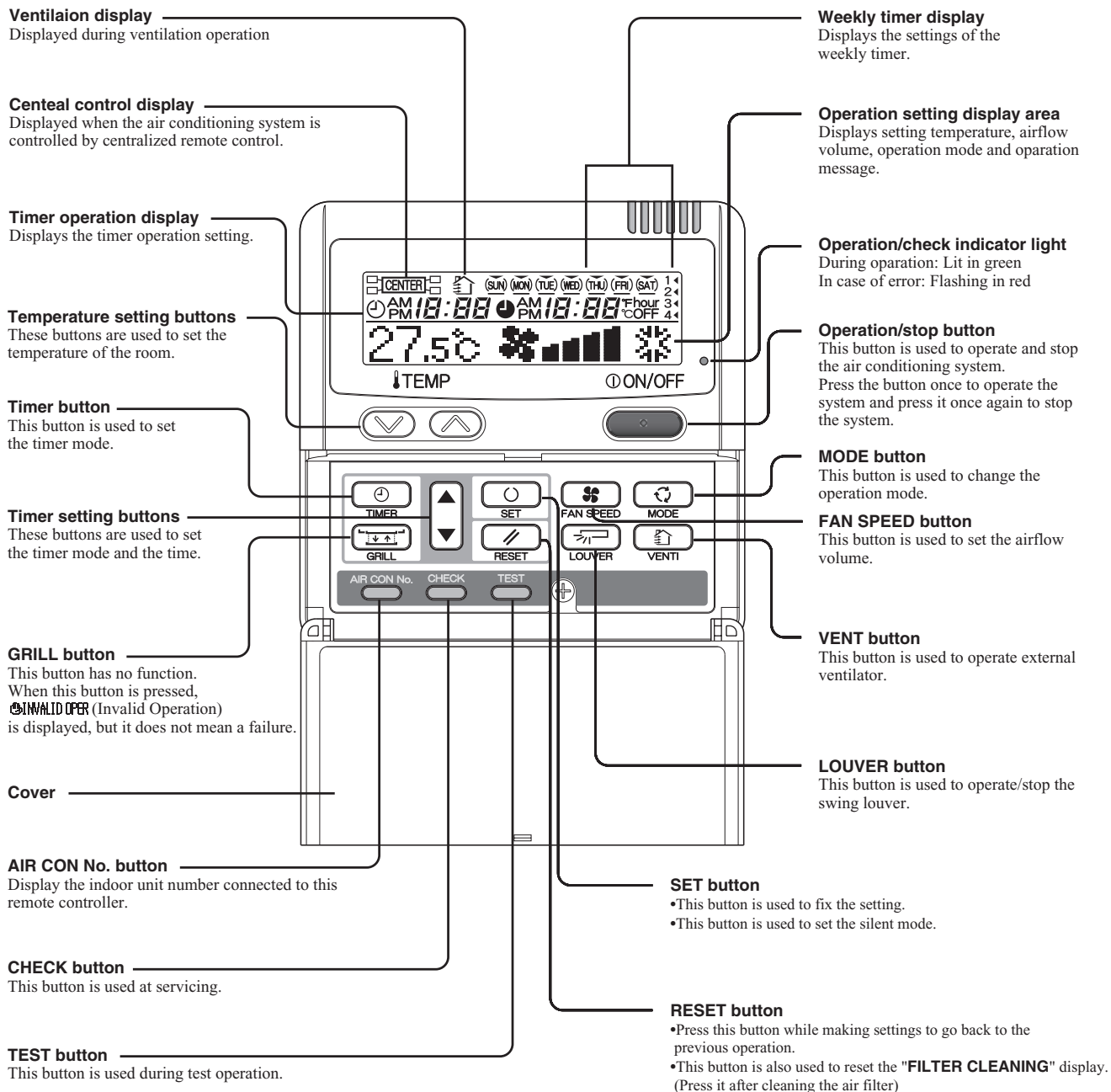

* All displays are described in the liquid crystal display for explanation.

(b) Wireless remote controller

◆FDEN series only

Indication section

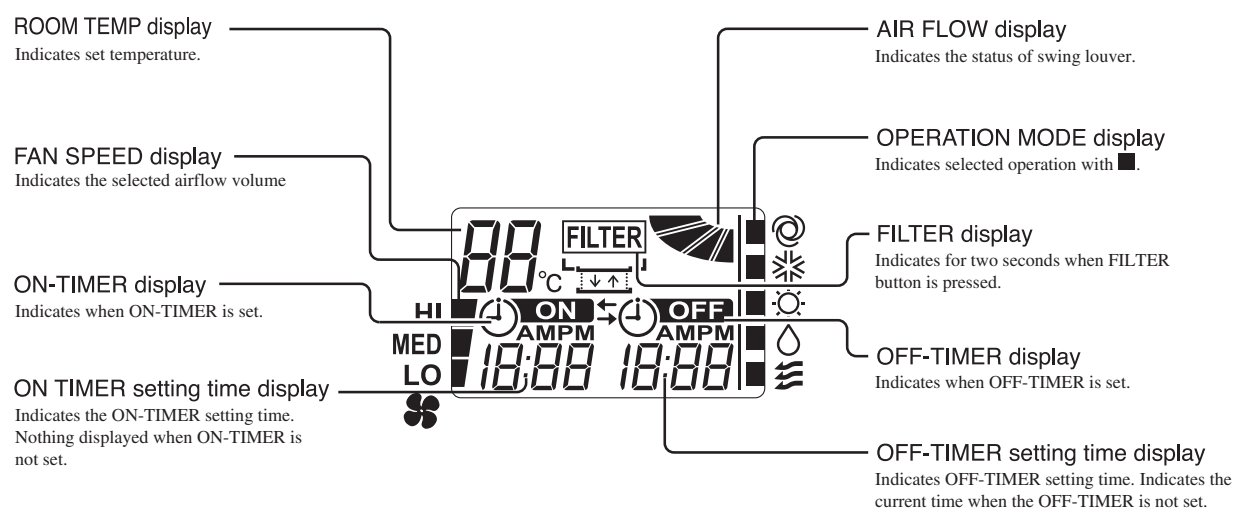

Operation section

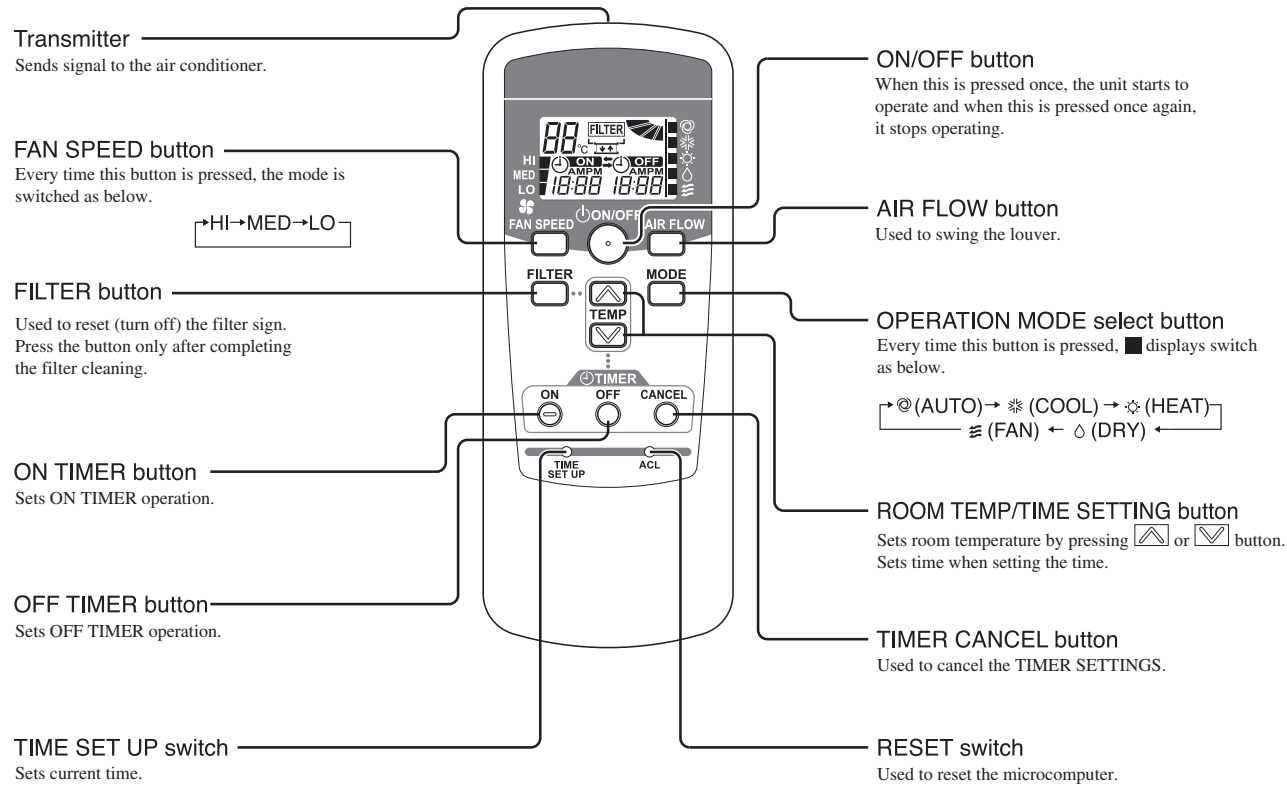

* All displays are described in the liquid crystal display for explanation

(2) Operation control function by the wired remote controller

(a) Switching sequence of the operation mode switches of remote controller

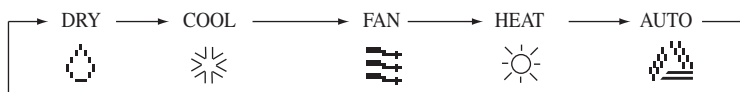

(b) [CPU reset]

This functions when “CHECK” and “GRILL” buttons on the remote controller are pressed simultaneously. Operation is same as that of the power supply reset.

(c) [Power failure compensation function]...Electric power supply failure

- This becomes effective if “Power failure compensation effective” is selected with the setting of remote controller function.
- Since it memorizes always the condition of remote controller, it starts operation according to the contents of memory no sooner than normal state is recovered after the power failure. Although the auto swing stop position and the timer mode are cancelled, the weekly timer setting is restored with the holiday setting for all weekdays.

After recovering from the power failure, it readjusts the clock and resets the holiday setting for each weekday so that the setting of weekly timer becomes effective.

- Content memorized with the power failure compensation are as follows.

Note (1) Items⑥, ⑦ and ⑧ are memorized regardless whether the power failure compensation is effective or not while the setting of silent mode is cancelled regardless whether the power failure compensation is effective or not.

① At power failure – Operating/stopped

If it had been operating under the off timer mode, sleep timer mode, the state of stop is memorized. (Although the timer mode is cancelled at the recovery from power failure, the setting of weekly timer is changed to the holiday setting for all weekdays.)

② Operation mode

③ Airflow volume mode

④ Room temperature setting

⑤ Louver auto swing/stop

However, the stop position (4-position) is cancelled so that it returns to Position (1).

⑥ “Remote controller function items” which have been set with the remote controller function setting (“Indoor function items” are saved in the memory of indoor unit.)

⑦ Upper limit value and lower limit value which have been set with the temperature setting control

⑧ Sleep timer and weekly timer settings (Other timer settings are not memorized.)

[Parts layout on remote controller PCB]

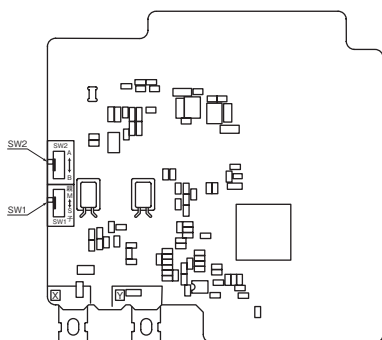

Master/ slave setting when more than one remote controllers are used

A maximum of two remote controllers can be connected to one indoor unit (or one group of indoor units.)

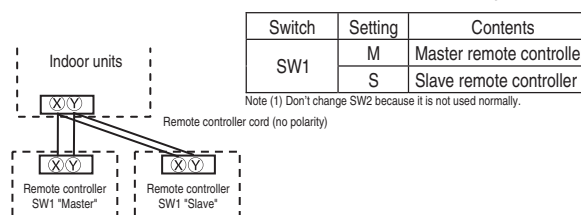

Caution

When using multiple remote controllers, the following displays or settings cannot be done with the slave remote controller. It is available only with the master remote controller.

- ① Louver position setting (set upper or lower limit of swinging range)
- ② Setting indoor unit functions
- ③ Setting temperature range
- ④ Operation data display
- ⑤ Error data display
- ⑥ Silent mode setting
- ⑦ Test operation of drain pump
- ⑧ Remote controller sensor setting

(3) Operation control function by the indoor controller

(a) Auto operation

If “Auto” mode is selected by the remote controller, the heating and the cooling are automatically switched according to the difference between outdoor air temperature and setting temperature and the difference between setting temperature and return air temperature. (When the switching of cooling mode ↔ heating mode takes place within 3 minutes, the compressor does not operate for 3 minutes by the control of 3-minute timer.) This will facilitate the cooling/heating switching operation in intermediate seasons and the adaptation to unmanned operation at stores, etc (ATM corner of bank).

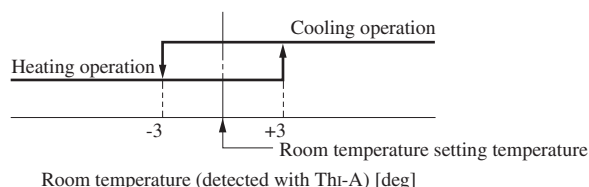

Note (1) Room temperature control during auto cooling/auto heating is performed according to the room temperature setting temperature. (DIFF: ±1 deg)
 (2) If the indoor heat exchanger temperature rises to 59°C or higher during heating operation, it is switched automatically to cooling operation. In addition, for 1 hour after this switching, the heating operation is not performed, regardless of the temperature shown at right.

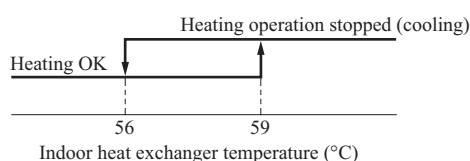

(b) Operations of functional items during cooling/heating

Operation Functional item	Cooling		Fan	Heating			Dehumidify
	Thermostat ON	Thermostat OFF		Thermostat ON	Thermostat OFF	Hot start (Defrost)	
Compressor	○	×	×	○	×	○	○/×
4-way valve	×	×	×	○	○	○(×)	×
Outdoor unit fan	○	×	×	○	×	○(×)	○/×
Indoor unit fan	○	○	○	○/×	○/×	○/×	○/×
Louver motor	○/×			○/×	○/×	○/×	○/×
Drain pump ⁽³⁾	○	× ⁽²⁾	× ⁽²⁾	○/× ⁽²⁾			Thermostat ON: ○ Thermostat OFF: × ⁽²⁾

Note (1) ○: Operation ×: Stop ○/×: Turned ON/OFF by the control other than the room temperature control.
 (2) ON during the drain motor delay control.
 (3) Drain pump ON setting may be selected with the indoor unit function setting of the wired remote controller.

(c) Dehumidifying operation

- 1) When the humidity sensor is not provided (Models other than FDT Series)
 Return air temperature thermistor [Th1-A (by the remote controller when the remote controller thermistor is enabled)] controls the indoor temperature environment simultaneously.
 - a) Operation is started in the cooling mode. When the difference between the return air temperature and the setting temperature is 2°C or less, the indoor unit fan tap is brought down by one tap. That tap is retained for 3 minutes after changing the indoor unit fan tap.
 - b) If the return air temperature exceeds the setting temperature by 3°C during defrosting operation, the indoor unit fan tap is raised. That tap is retained for 3 minutes after changing the indoor unit fan tap.
 - c) If the thermostat OFF is established during the above control, the indoor unit fan tap at the thermostat ON is retained so far as the thermostat is turned OFF.
 - d) After stopping the cooling operation, the indoor unit continues to run at Lo for 15 seconds.
- 2) When the humidity thermistor is provided (FDT Series only) [Optional]
 - a) Operation starts in the cooling mode, and the target relative temperature is determined based on the setting temperature. If the humidity detected by the humidity thermistor becomes lower than the target relative temperature, the indoor unit fan tap is retained.
 - b) Anything other than a) above is same as the item 1) above.

(d) Timer operation

- 1) Sleep timer
Set the duration of time from the present to the time to turn off the air-conditioner.
It can be selected from 10 steps in the range from “OFF 1 hour later” to “OFF 10 hours later”. After the sleep timer setting, the remaining time is displayed with progress of time in the unit of hour.
- 2) OFF timer
Time to turn OFF the air-conditioner can be set in the unit of 10 minutes.
- 3) ON timer
Time to turn ON the air-conditioner can be set. Indoor temperature can be set simultaneously.
- 4) Weekly timer
Timer operation (ON timer, OFF timer) can be set up to 4 times a day for each weekday.
- 5) Timer operations which can be set in combination

Item \ Item	Sleep timer	OFF timer	ON timer	Weekly timer
Sleep timer		×	○	×
OFF timer	×		○	×
ON timer	○	○		×
Weekly timer	×	×	×	

Note (1) ○: Allowed ×: Not

(e) Remote controller display during the operation stop

- 1) “Centralized control ON” is displayed always on the LCD under the “Center/Remote” and “Center” modes during the operation stop (Power ON). This is not displayed under the “Remote” mode.
- 2) If this display is not shown under the “Center/Remote” mode, check if the indoor unit power switch is turned on or not.

(f) Hot start (Cold draft prevention at heating)

At the startup of heating operation, at resetting of the thermostat, during defrost operation and at returning to heating, the indoor fan is controlled by the indoor heat exchanger temperature (detected with Thi-R) for preventing the cold draft.

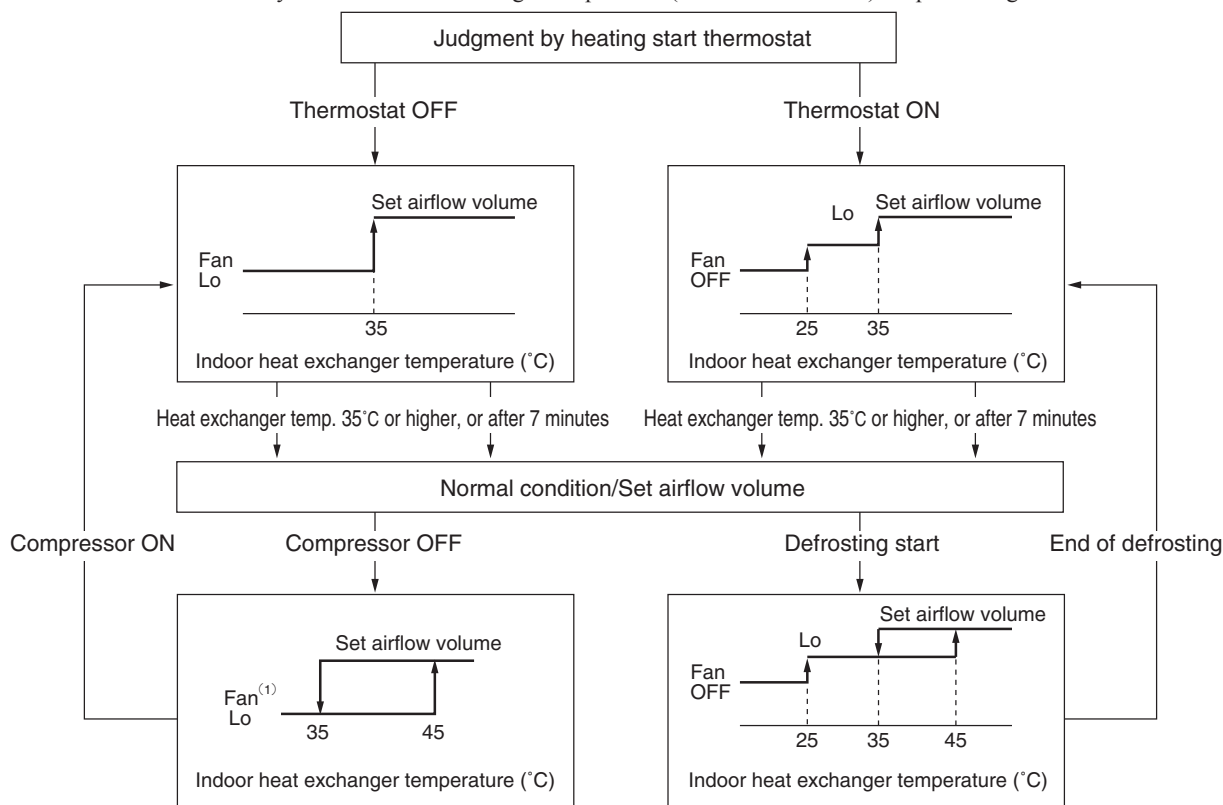

Note (1) Heating preparation is displayed during the hot start (when the compressor is operating and the indoor fan does not provide the set airflow volume).

(g) Hot keep

Hot keep control is performed at the start of the defrost control.

- 1) Control
 - a) When the indoor heat exchanger temperature (detected with Th_i-R1 or R2) drops to 35°C or lower, the speed of indoor fan is changed to the lower tap at each setting.
 - b) During the hot keep, the louver horizontal control signal is transmitted.
- 2) Ending condition

When the indoor fan is at the lower tap at each setting, it returns to the set airflow volume as the indoor heat exchanger temperature rises to 45°C or higher.

(h) Fan control during the heating thermostat OFF

When the heating thermostat is turned OFF, the setting of the fan control is selectable using the indoor function of wired remote controller [☼ FAN CONTROL].

- 1) Low fan speed (Factory default)

If the indoor heat exchanger temperature drops below 35°C with the heating thermostat OFF, the indoor fan operate at the lower speed tap at each setting.
- 2) Set fan speed

Even if the indoor heat exchanger temperature drops below 35°C with the heating thermostat OFF, the indoor fan continues to run at the set airflow volume.
- 3) Intermittence

If the indoor heat exchanger temperature drops below 35°C with the heating thermostat OFF, the indoor fan operates at the lower speed tap at each setting and, when the indoor heater exchanger temperature drops below 25°C, the indoor fan stops for 5 minutes. Then the fan runs at the low speed tap for 2 minutes, and the judgment is made by the thermostat.
- 4) Fan OFF

If the indoor heat exchanger temperature drops below 35°C with the heating thermostat OFF, the indoor fan is turned OFF. The same applies also when the remote controller sensor is effective.

(i) Filter sign

As the operation time (Total ON time of ON/OFF switch) accumulates to 180 hours (1), “FILTER CLEANING” is displayed on the remote controller. (This is displayed when the unit is in trouble and under the centralized control, regardless of ON/OFF)



Note (1) Time setting for the filter sign can be made as shown below using the indoor function of wired remote controller “FILTER SIGN SET”. (It is set at 1 at the shipping from factory.)

Filter sign setting	Function
TYPE 1	Setting time: 180 hrs (Factory default)
TYPE 2	Setting time: 600 hrs
TYPE 3	Setting time: 1,000 hrs
TYPE 4	Setting time: 1,000 hrs (Unit stop) ⁽²⁾

(2) After the setting time has elapsed, the “FILTER CLEANING” is displayed and, after operating for 24 hours further (counted also during the stop), the unit stops.

(j) Auto swing control [Applicable model: FDTC, FDT and FDEN]

1) Louver control

- a) Press the “LOUVER” button to operate the swing louver when the air conditioner is operating.
“SWING ” is displayed for 3 seconds and then the swing louver moves up and down continuously.
- b) To fix the swing louver at a position, press one time the “LOUVER” button while the swing louver is moving so that four stop positions are displayed one after another per second.
When a desired stop position is displayed, press the “LOUVER” button again. The display stops, changes to show the “STOP 1 ” for 5 seconds and then the swing louver stops.
- c) Louver operation at the power on with a unit having the louver 4-position control function
The louver swings one time automatically (without operating the remote controller) at the power on.
This allows inputting the louver motor (LM) position, which is necessary for the microcomputer to recognize the louver position.



Note (1) If you press the “LOUVER” button, the swing motion is displayed on the louver position LCD for 10 second. The display changes to the “SWING ” display 3 seconds later.

2) Automatic louver level setting during heating

At the hot start with the heating thermostat OFF, regardless whether the auto swing switch is operated or not (auto swing or louver stop), the louver takes the level position (In order to prevent the cold start). The louver position display LCD continues to show the display which has been shown before entering this control.

3) Louver-free stop control

When the louver-free stop has been selected with the indoor function of wired remote controller “ POSITION”, the louver motor stops when it receives the stop signal from the remote controller. If the auto swing signal is received from the remote controller, the auto swing will start from the position where it was before the stop.

Note (1) When the indoor function of wired remote controller “ POSITION” has been switched, switch also the remote control function “ POSITION” in the same way.

4) Individual flap (louver) control system

Regarding FDT and FDTC models, the individual flaps (louvers) for 4 directions can be controlled to swing within the ranges between upper limit and lower limit selected with wired remote control respectively.

For detail setting method, refer to ⑦ in page 145 for FDTC or ⑨ in page 151 for FDT.

The single flap (louver) of FDE model can also be controlled to swing like FDT and FDTC.

(refer to ⑪ in page 155 for details)

Note (1) The function is not able to be set with wireless remote controls or simple remote control (RCH-E3)

(k) Compressor inching prevention control

1) 3-minute timer

When the compressor has been stopped by the thermostat, remote controller operation switch or anomalous condition, its restart will be inhibited for 3 minutes. However, the 3-minute timer is invalidated at the power on the electric power source for the unit.

2) 3-minute forced operation timer

- Compressor will not stop for 3 minutes after the compressor ON. However, it stops immediately when the unit is stopped by means of the ON/OFF switch or by when the thermister turned OFF the change of operation mode.
- If the thermostat is turned OFF during the forced operation control of heating compressor, the louver position (with the auto swing) is returned to the level position.

Note (1) The compressor stops when it has entered the protective control.

(l) Drain motor (DM) control [Applicable model: FDTC, FDT and FDUM]

- 1) Drain motor (DM) is operated during the cooling or dehumidifying mode operations and simultaneously with the compressor ON. The DM continues to operate for 5 minutes after the operation stop, anomalous stop, thermostat stop or when it was switched from the cooling and dehumidifying operations to the fan or heating operation.

	Indoor unit operation mode				
	Stop ⁽¹⁾	Cooling	Dehumidifying	Fan ⁽²⁾	Heating
Compressor ON		Control A			
Compressor OFF	Control B				

Note (1) Including the stop from the cooling, dehumidifying, fan and heating, and the anomalous stop
 (2) Including the "Fan" operation according to the mismatch of operation modes

a) Control A

- i) If the float switch detects any anomalous draining condition, the unit stops with the anomalous stop (displays E9) and the drain pump starts. After detecting the anomalous condition, the drain motor continues to be ON.
- ii) It keeps operating while the float switch is detecting the anomalous condition.

b) Control B

If the float switch detects any anomalous drain condition, the drain motor is turned ON for 5 minutes, and at 10 seconds after the drain motor OFF it checks the float switch. If it is normal, the unit is stopped under the normal mode or, if there is any anomalous condition, E9 is displayed and the drain motor is turned ON. (The ON condition is maintained during the drain detection.)

2) Drain motor (DM) interlock control

a) Start conditions

Depending on the function setting by the remote controller, the drain motor is turned ON under either one of the following conditions.

- i) During heating mode operation (Both the thermostat ON/OFF)
- ii) During heating mode operation (Both the thermostat ON/OFF) + Fan operation
- iii) Fan operation

b) End conditions

The drain motor is turned OFF 5 minutes after the stop of operations i) to iii) above.

(m) Operation check/drain pump test run operation mode

- 1) If the power is turned on by the dip switch (SW7-1) on the indoor PCB when electric power source is supplied, it enters the mode of operation check/drain pump test run. It is ineffective (prohibited) to change the switch after turning power on.
- 2) When the communication with the remote controller has been established within 60 seconds after turning power on by the dip switch (SW7-1) ON, it enters the operation check mode. Unless the remote controller communication is established, it enters the drain pump test run mode.

Note (1) To select the drain pump test run mode, disconnect the remote controller connector (CNB) on the indoor PCB to shut down the remote controller communication.

3) Operation check mode

There is no communication with the outdoor unit but it allows performing operation in respective modes by operating the remote controller.

4) Drain pump test run mode

As the drain pump test run is established, the drain pump only operates and during the operation protective functions by the microcomputer of indoor unit become ineffective.

(n) Cooling, dehumidifying frost protection

- 1) To prevent frosting during cooling mode or dehumidifying mode operation, the of compressor speed is reduced if the indoor heat exchanger temperature (detected with $Thi-R$) drops to 1.0 °C or lower at 4 minutes after the start of compressor operation. If the indoor unit heat exchanger temperature is 1.0 °C or lower after 1 minutes, the compressor speed is reduced further. If it becomes 2.5 °C or higher, the control terminates. When the indoor heat exchanger temperature has become as show below after reducing the compressor speed, it is switched to the fan operation. For the selection of indoor fan speed, refer to item 2).

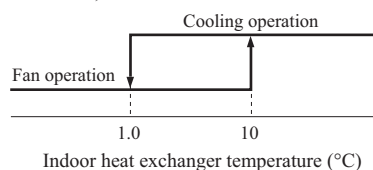

2) Selection of indoor fan speed

If it enters the frost prevention control during cooling operation (excluding dehumidifying), the indoor unit fan speed is switched.

(a) In cases of FDTC, FDUM, FDU and FDEN

- i) When the indoor unit return air temperature (detected with $Thi-A$) is 23°C or lower, this control is invalidated and, as 2 hours elapse after starting the frost prevention control, it is terminated.
- ii) If it is detected again within 15 minutes from the start of frost prevention control, the indoor fan speed is raised by 1 tap to increase the indoor unit fan speed. If it is detected within further 15 minutes, the indoor unit fan speed is raised by 1 tap more.

Note (1) Indoor unit fan speed can be increased by up to 2 taps.

- iii) “ FAN SPEED SW VALID/INVALID” of this control is selectable with the function setting of remote controller.

b) In the case of FDT

- i) When the indoor return air detection temperature (detected with $Thi-A$) is 23°C or higher and the indoor heat exchanger temperature (detected with $Thi-R$) detects the compressor frequency drop start temperature $A^{\circ}C+1^{\circ}C$, of indoor unit fan speed is increased by 20rpm.
- ii) If the phenomenon of i) above is detected again after the acceleration of indoor unit fan, indoor unit fan speed is increased further by 20rpm.

Note (1) Indoor unit fan speed can be increased by up to 2 taps.

• Compressor frequency drop start temperature

Item	Symbol	A
Temperature - Low (Factory default)		1.0
Temperature - High		2.5

Note (1) Frost prevention temperature setting can be selected with the indoor unit function setting of the wired remote controller.

(o) Heating overload protection

- 1) If the indoor heat exchanger temperature (detected with $Thi-R$) at 63°C or higher is detected for 2 seconds continuously, the compressor stops. When the compressor is restarted after a 3-minute delay, if a temperature at 63°C or higher is detected for 2 seconds continuously within 60 minutes after initial detection and if this is detected 5 times consecutively, the compressor stops with the anomalous stop (E8). Anomalous stop occurs also when the indoor heat exchanger temperature at 63°C or higher is detected for 6 minutes continuously.

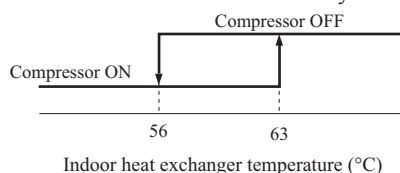

2) Indoor unit fan speed selection

If, after second detection of heating overload protection up to fourth, the indoor fan is set at Me and Lo taps when the compressor is turned ON, the indoor fan speed is increased by 1 tap.

(p) Anomalous fan motor [In case of FDT, FDTC only]

After starting the fan motor, if the fan motor speed is 200rpm or less is detected for 30 seconds continuously and 4 times within 60 minutes, then fan motor stops with the anomalous stop (E16).

(q) Plural unit control – Control of 16 units group by one remote controller

1) Function

One remote controller switch can control a group of multiple number of unit (Max. 16 indoor units). “Operation mode” which is set by the remote controller switch can operate or stop all units in the group one after another in the order of unit No.⁽¹⁾. Thermostat and protective function of each unit function independently.

Note (1) Unit No. is set by SW2 on the indoor unit control PCB. Unit No. setting by SW2 is necessary for the indoor unit only. In cases of the twin, triple and double-twin specification, it is necessary set for the master and the slave units. This can be selected by SW5. (All are set for the master unit at the shipping from factory.)

SW2: For setting of 0 – 9, A – F

SW5: For setting of master and slave units

(See table shown at right.)

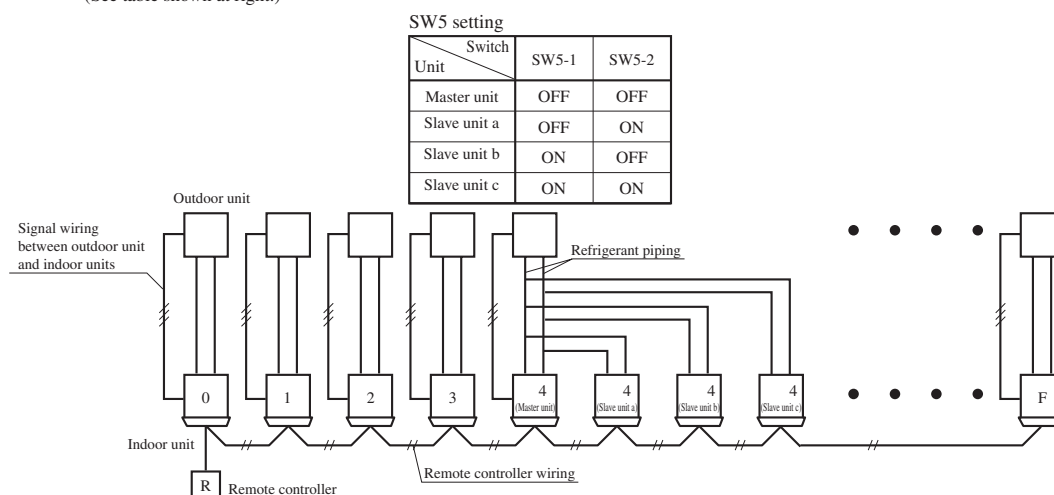

(2) Unit No. may be set at random unless duplicated, it should be better to set orderly like 0, 1, 2, ..., F to avoid mistake.

2) Display to the remote controller

- a) Center or each remote controller basis, heating preparation: the youngest unit No. among the operating units in the remote mode (or the center mode unless the remote mode is available) is displayed.
- b) Inspection display, filter sign: Any of unit that starts initially is displayed.
- c) Confirmation of connected units
Pressing “AIR CON No.” button on the remote controller displays the indoor unit address. If “▲” “▼” button is pressed at the next, it is displayed orderly starting from the unit of youngest No.
- d) In case of anomaly
 - i) If any anomaly occurs on a unit in a group (a protective function operates), that unit stops with the anomalous stop but any other normal units continue to run as they are.
 - ii) Signal wiring procedure
Signal wiring between indoor and outdoor units should be made on each unit same as the normal wiring. For the group control, lay connect with sires wiring between rooms using terminal blocks (X, Y) of remote controller.
Connect the remote controller communication wire separately from the power supply wire or wires of other electric devices (AC220V or higher).

(r) High ceiling control

In the case of indoor unit installed in a higher ceiling room, the airflow volume mode control can be changed with the wired remote controller indoor unit function “FAN SPEED SET”.

Fan tap		Indoor unit airflow setting			
		※all - ※all - ※all - ※all	※all - ※all - ※all	※all - ※all	※all - ※all
FAN SPEED SET	STANDARD	PHi - Hi - Me - Lo	Hi - Me - Lo	Hi - Lo	Hi - Me
	HIGH SPEED1, 2	PHi - PHi - Hi - Me	PHi - Hi - Me	PHi - Me	PHi - Hi

Note (1) Factory default is Standard.

(2) At the hot-start and heating thermostat OFF, or other, the indoor unit fan is operated at the low speed tap of each setting.

(3) This function is not able to be set with wireless remote controls or simple remote control (RCH-E3)

(s) Abnormal temperature thermistor (return air/indoor heat exchanger) wire/short-circuit detection

1) Broken wire detection

When the return air temperature thermistor detects -50°C or lower or the heat exchanger temperature thermistor detect -50°C or lower for 5 seconds continuously, the compressor stops. After a 3-minute delay, the compressor restarts but, if it is detected again within 60 minutes after the initial detection for 6 minutes continuously, stops again (the return air temperature thermistor: E7, the heat exchanger temperature thermistor: E6).

2) Short-circuit detection

If the heat exchanger temperature thermistor detects 70°C or higher for 5 seconds continuously at 2 minutes and 20 seconds after the compressor ON during cooling operation, the compressor stops (E6).

(t) Operation permission/prohibition

(In case of adopting card key switches or commercially available timers)

When the indoor function setting of wired remote controller for “Operation permission/prohibition” is changed from “Invalid (Factory default)” to “Valid”, following control becomes effective.

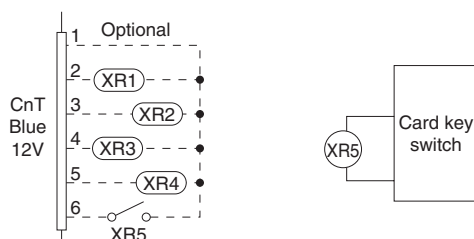

CnT-6	Normal operation (Factory default)		Operation permission/prohibition mode “Valid” (Local setting)	
	ON	OFF	ON	OFF
	Operation	Stop	Operation permission*1	Operation prohibition (Unit stops)

*1 **Only the “LEVEL INPUT” is acceptable for external input**, however when the indoor function setting of “Level input (Factory default)” or “Pulse input” is selected by the function for “External input” of the wired remote controller, operation status will be changed as follows.

In case of “Level input” setting	In case of “Pulse input” setting
Unit operation from the wired remote controller becomes available*(1)	Unit starts operation *(2)

* (1) In case that “Operation permission/prohibition mode” setting is “Valid” and “External input” setting is “Level input (Factory default)”;

- ① When card key switch is ON (CnT-6 ON: Operation permission), start/stop operation of the unit from the wired remote controller becomes available.
- ② When card key switch is OFF (CnT-6 OFF: Operation prohibition), the unit stops operation in conjunction with OFF signal, and start/stop operation of the unit from the wired remote controller becomes not available.

* (2) In case that “Operation permission/prohibition mode” setting is “Valid” and “External input” setting is “Pulse input (Local setting)”;

- ① When card key switch is ON (Operation permission), the unit starts operation in conjunction with ON signal. and also start/stop operation of the unit from the wired remote controller becomes available.
- ② When card key switch is OFF (Operation prohibition), the unit stops operation in conjunction with OFF signal, and start/stop operation of the unit from the wired remote controller becomes not available.

(3) This function is invalid only at “Center mode” setting done by central controller.

(u) External input/output control (CnT)

Be sure to connect the wired remote controller to the indoor unit. Without wired remote controller remote operation by CnT is not possible to perform.

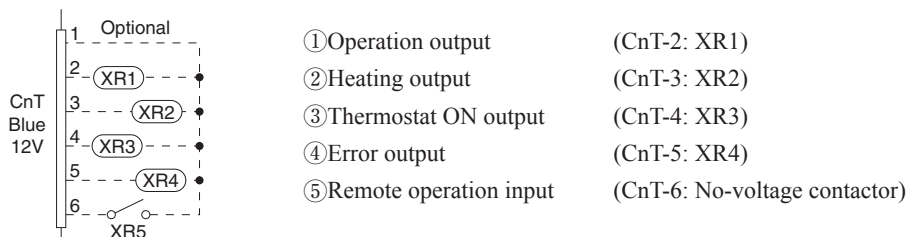

1) Output for external control (remote display)

Following output connectors (CnT) are provided on the indoor control PCB for monitoring operation status.

- ① **Operation output:** Outputs DC12V signal for driving relay during operation
- ② **Heating output:** Outputs DC12V signal for driving relay during heating operation
- ③ **Thermostat ON output:** Outputs DC12V signal for driving relay when compressor is operating.
- ④ **Error output:** Outputs DC12V signal for driving relay when anomalous condition occurs.

2) Remote operation input

Remote operation input connector (CnT-6) is provided on the indoor control PCB.

However remote operation by CnT-6 is not effective, when “Center mode” is selected by center controller.

In case of plural unit (twin, triple, double twin), remote operation input to CnT-6 on the slave indoor unit is invalid.

Only the “LEVEL INPUT” is acceptable for external input, however when the indoor function setting of “Level input (Factory default)” or “Pulse input” is selected by the function for “External input” of the wired remote controller, operation status will be changed as follows.

a) In case of “Level input” setting (Factory default)

Input signal to CnT-6 is OFF→ON unit ON

Input signal to CnT-6 is ON→OFF unit OFF

Operation is not inverted.

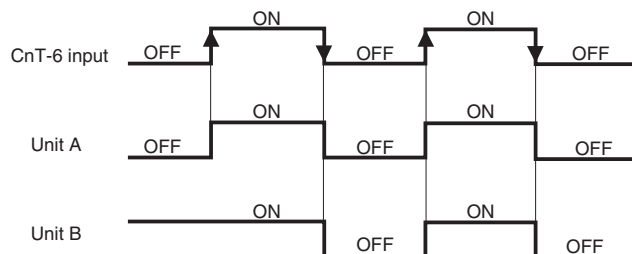

Note: The latest operation has priority

It is available to operate/stop by remote controller or center controller

b) In case of “Pulse input” setting (Local setting)

It is effective only when the input signal to CnT-6 is changed OFF→ON, and at that time unit operation [ON/OFF] is inverted.

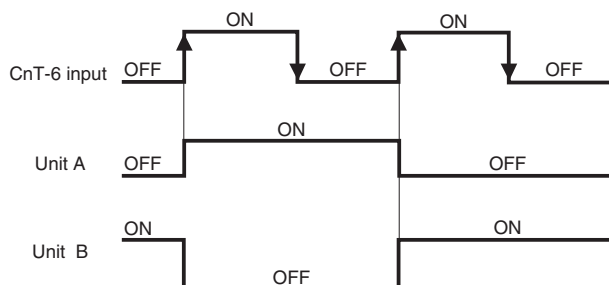

3) Remote operation

a) In case of multiple units (Max. 16 indoor units group) are connected to one wired remote controller

When the indoor function setting of wired remote controller for “External control set” is changed from “Individual (Factory default)” to “For all units”, all units connected in one wired remote controller system can be controlled by external operation input.

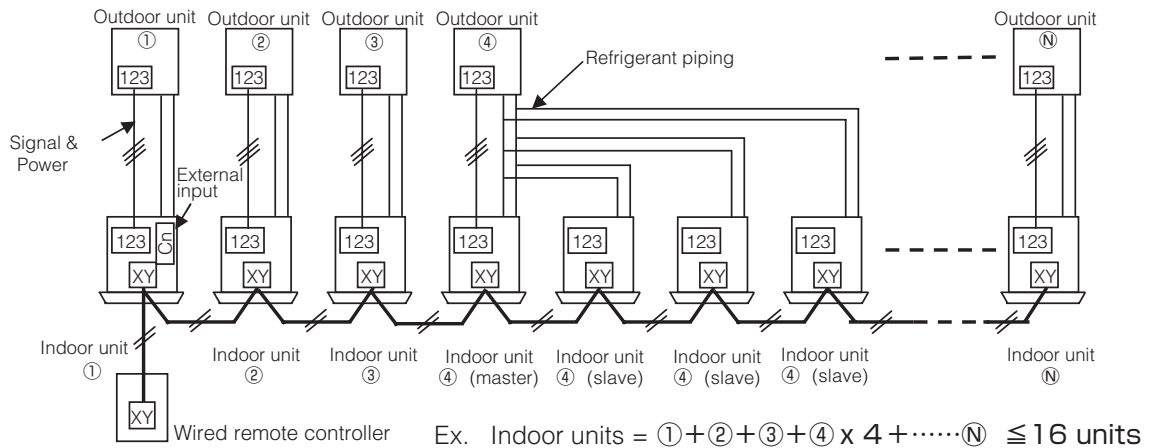

CnT-6	Individual operation (Factory default)		All units operation (Local setting)	
	ON	OFF	ON	OFF
	Only the unit directly connected to the remote controller can be operated.	Only the unit directly connected to the remote controller can be stopped operation.	All units in one remote controller system can be operated.	All units in one remote controller system can be stopped operation.
	Unit ① only	Unit ① only	Units ① – ⑩	Units ① – ⑩

When more than one indoor unit (Max. 16 indoor units) are connected in one wired remote controller system:

- (1) With the factory default, external input to CnT-6 is effective for only the unit ①.
- (2) When setting “For all unit” (Local setting), all units in one remote controller system can be controlled by external input to CnT-6 on the indoor unit ①.
- (3) External input to CnT-6 on the other indoor unit than the unit ① is not effective.

(v) Fan control at heating startup (Applicable model: FDTC and FDT)

- 1) Start conditions
At the start of heating operation, if the difference of setting temperature and return air temperature is 5°C or higher after the end of hot start control, this control is performed.
- 2) Contents of control
 - a) Sampling is made at each minute and, when the indoor unit heat exchanger temperature (detected with Thr-R) is 37°C or higher, present number of revolutions of indoor unit fan speed is increased by 10min⁻¹.
 - b) If the indoor unit heat exchanger temperature drops below 37°C at next sampling, present number of revolutions of indoor unit fan speed is reduced by 10min⁻¹.
- 3) End conditions
Indoor fan speed is reduced to the setting airflow volume when the compressor OFF is established and at 30 minutes after the start of heating operation.

(w) Room temperature detection temperature compensation during heating

With the standard specification, the compressor is turned ON/OFF with the thermostat setting temperature. When the thermostat is likely to turn OFF earlier because the unit is installed at the ceiling where warm air tends to accumulate, the setting can be changed with the wired remote controller indoor unit function “※ SP OFFSET”. The compressor and the heater are turned ON/OFF at one of the setting temperature +3, +2 or +1°C in order to improve the feeling of heating. The setting temperature, however, has the upper limit of 30°C.

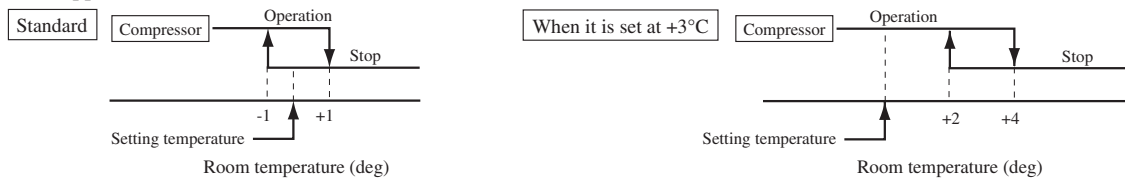

(x) Return air temperature compensation

This is the function to compensate the deviation between the detection temperature by the return air temperature thermistor and the measured temperature after installing the unit.

- 1) It is adjustable in the unit of 0.5°C with the wired remote controller indoor unit function “RETURN AIR TEMP”.
 - +1.0°C, +1.5°C, +2.0°C • -1.0°C, -1.5°C, -2.0°C
 - 2) Compensated temperature is transmitted to the remote controller and the compressor to control them.
- Note (1) The detection temperature compensation is effective on the indoor unit thermistor only.

(4) Operation control function by the outdoor controller

(I) SRC40 ~ 60 models

(a) Defrosting operation

- 1) Starting conditions (Defrosting operation can be started only when all of the following conditions are met.)
 - a) After start of heating operation
When it elapsed 35 minutes. (Accumulated compressor operation time)
 - b) After end of defrosting operation
When it elapsed 35 minutes. (Accumulated compressor operation time)
 - c) Outdoor heat exchanger sensor (TH1) temperature
When the temperature has been below -5°C for 3 minutes continuously.
 - d) The difference between the outdoor air sensor temperature and the outdoor heat exchanger sensor temperature
 - The outdoor air temperature $\geq -2^{\circ}\text{C}$: 7°C or higher
 - $-15^{\circ}\text{C} \leq$ The outdoor air temperature $< -2^{\circ}\text{C}$: $4/15 \times$ The outdoor air temperature $+ 7^{\circ}\text{C}$ or higher
 - The outdoor air temperature $< -15^{\circ}\text{C}$: -5°C or higher
 - e) During continuous compressor operation
In addition, when the speed command from the indoor controller of the indoor unit during heating operation has counted 0 rps 10 times or more and all conditions of a), b), c) and e) above and the outdoor air temperature is 3°C or less are satisfied (note that when the temperature for outdoor heat exchanger sensor (TH1) is -5°C or less: 62 rps or more, -4°C or less: less than 62 rps), defrost operation is started.
- 2) Ending conditions (Operation returns to the heating cycle when either one of the following is met.)
 - a) Outdoor heat exchanger sensor (TH1) temperature: 10°C or higher
 - b) Continued operation time of defrosting \rightarrow For more than 15 min.

(b) Cooling overload protective control

- 1) **Operating conditions:** When the outdoor air temperature (TH2) is 41°C or higher continues for 30 seconds while the compressor command speed of other than 0 rps.
- 2) **Detail of operation**
 - a) The outdoor fan is stepped up by 3 speed step. (Upper limit 8th speed.)
 - b) The lower limit of compressor command speed is set to 30 rps and even if the calculated result becomes lower than that after fuzzy calculation, the speed is kept to 30 rps. However, when the thermo becomes OFF, the speed is reduced to 0 rps.
- 3) **Reset conditions:** When either of the following condition is satisfied.
 - a) The outdoor air temperature is lower than 40°C .
 - b) The compressor command speed is 0 rps.

(c) Cooling high pressure control

- 1) **Purpose:** Prevents anomalous high pressure operation during cooling.
- 2) **Detector:** Outdoor heat exchanger sensor (TH1)
- 3) **Detail of operation:**

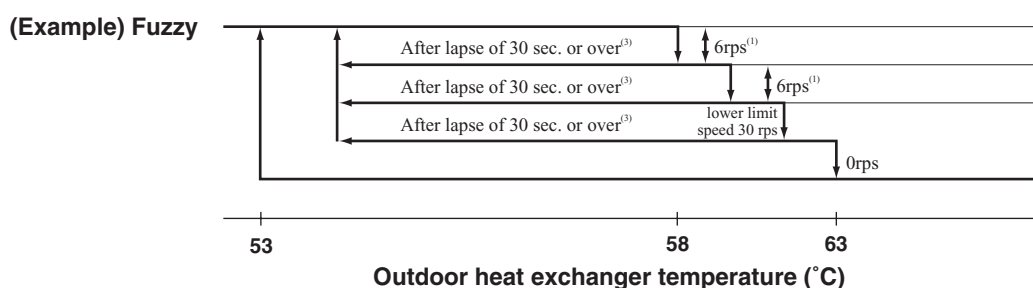

- Notes
- (1) When the outdoor heat exchanger temperature is in the range of $58\text{--}63^{\circ}\text{C}$, the speed is reduced by 6 rps at each 30 seconds.
 - (2) When the temperature is 63°C or higher, the compressor is stopped.
 - (3) When the outdoor heat exchanger temperature is in the range of $53\text{--}58^{\circ}\text{C}$, if the compressor command speed is been maintained and the operation has continued for more than 30 seconds at the same speed, it returns to the normal cooling operation.

(d) Cooling low outdoor temperature protective control

1) **Operating conditions:** When the outdoor air temperature (TH2) is 22°C or lower continues for 20 seconds while the compressor command speed is other than 0 rps.

2) **Detail of operation:**

- a) The lower limit of the compressor command speed is set to 44 (30) rps and even if the speed becomes lower than 44 (30) rps, the speed is kept to 44 (30) rps. However, when the thermo becomes OFF, the speed is reduced to 0 rps.
- b) The upper limit of the compressor command speed is set to 50 (60) rps and even if the calculated result becomes higher than that after fuzzy calculation, the speed is kept to 50 (60) rps.

Note (1) Values in () are for outdoor air temperature is C or D.

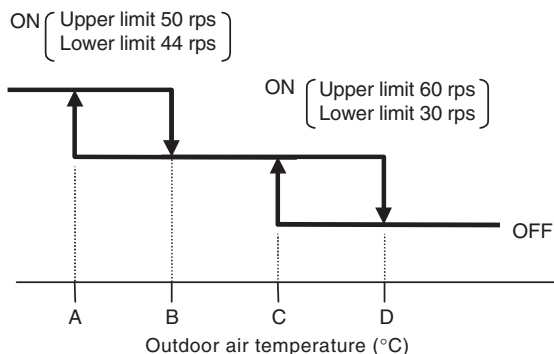

• Values of A, B, C, D

	Outdoor air temp. (°C)			
	A	B	C	D
First time	0	3	22	25
Since the seconds times	7	10	25	28

3) **Reset conditions:** When either of the following condition is satisfied

- a) The outdoor air temperature (TH2) is D °C or higher.
- b) The compressor command speed is 0 rps.

(e) Heating high pressure control

1) **Purpose:** Prevents anomalous high pressure operation during heating.

2) **Detector:** Indoor heat exchanger thermistor (ThI-R)

3) **Detail of operation:**

(Example) Fuzzy

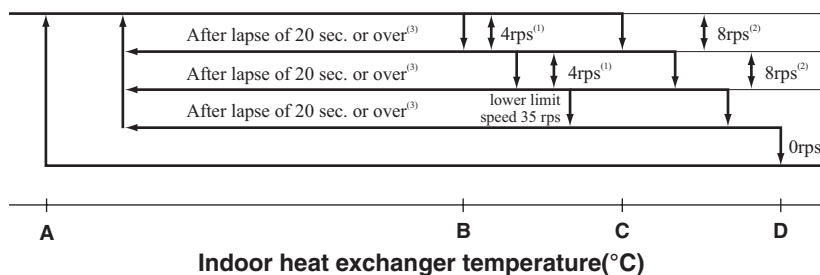

- Notes
- (1) When the indoor heat exchanger temperature is in the range of B~C °C, the speed is reduced by 4 rps at each 20 seconds.
 - (2) When the indoor heat exchanger temperature is in the range of C~D °C, the speed is reduced by 8 rps at each 20 seconds. When the temperature is D °C or higher continues for 1 minute, the compressor is stopped.
 - (3) When the indoor heat exchanger temperature is in the range of A~B °C, if the compressor command speed is been maintained and the operation has continued for more than 20 seconds at the same speed, it returns to the normal heating operation.
 - (4) Indoor blower retains the fan tap when it enters in the high pressure control. Outdoor blower is operated in accordance with the speed.

• **Temperature list**

	Unit : °C			
	A	B	C	D
RPSmin < 88	48.5	56	58	61
88 ≤ RPSmin < 108	44	51.5	53.5	56.5
108 ≤ RPSmin	39	46.5	48.5	51.5

Note (1) RPSmin: The lower one between the outdoor speed and the compressor command speed

(f) Heating overload protective control

- 1) **Operating conditions:** When the outdoor air temperature (TH2) is 17°C or higher continues for 30 seconds while the compressor command speed other than 0 rps.
- 2) **Detail of operation:**
 - a) Taking the upper limit of compressor command speed range at 50 rps, if the output speed obtained with the fuzzy calculation exceeds the upper limit, the upper limit value is maintained.
 - b) The lower limit of compressor command speed is set to 35 rps and even if the calculated result becomes lower than that after fuzzy calculation, the speed is kept to 35 rps. However, when the thermo becomes OFF, the speed is reduced to 0 rps.
 - c) Inching prevention control is activated and inching prevention control is carried out with the minimum speed set at 35 rps.
 - d) The outdoor fan is set on 2nd speed.
- 3) **Reset conditions:** The outdoor air temperature (TH2) is lower than 16°C.

(g) Heating low outdoor temperature protective control

- 1) **Operating conditions:** When the outdoor air temperature (TH2) is lower than 4°C or 13°C or higher continues for 30 seconds while the compressor command speed is other than 0 rps.
- 2) **Detail of operation:** The lower limit compressor command speed is change as shown in the figure below.

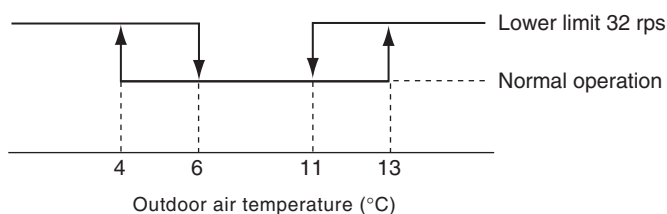

- 3) **Reset conditions:** When either of the following condition is satisfied.
 - a) The outdoor air temperature (TH2) becomes 6°C ~ 11°C.
 - b) The compressor command speed is 0 rps.

(h) Compressor overheat protection

- 1) **Purpose:** It is designed to prevent deterioration of oil, burnout of motor coil and other trouble resulting from the compressor overheat.
- 2) **Detail of operation**

a) Speeds are controlled with temperature detected by the sensor mounted on the discharge pipe.

(Example) Fuzzy

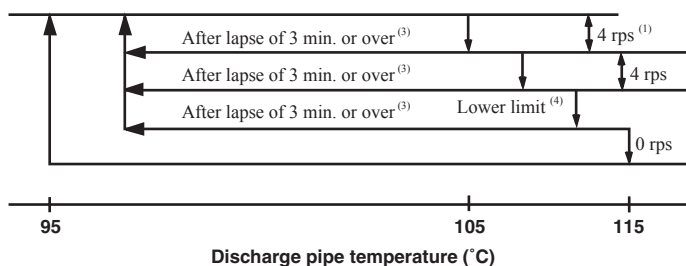

- Notes
- (1) When the discharge pipe temperature is in the range of 105~115°C, the speed is reduced by 4 rps.
 - (2) When the discharge pipe temperature is raised and continues operation for 20 seconds without changing, then the speed is reduced again by 4 rps.
 - (3) If the discharge pipe temperature is in the range of 95~105°C even when the compressor command speed is maintained for 3 minutes when the temperature is in the range of 95~105°C, the speed is raised by 1 rps and kept at that speed for 3 minutes. This process is repeated until the command speed is reached.
 - (4) Lower limit speed

	Cooling	Heating
Lower limit speed	25 rps	32 rps

- b) If the temperature of 115°C is detected by the sensor on the discharge pipe, then the compressor will stop immediately. When the discharge pipe temperature drops and the time delay of 3 minutes is over, the unit starts again within 1 hour but there is no start at the third time.

(i) **Current safe**

- 1) **Purpose:** Current is controlled not to exceed the upper limit of the setting operation current.
- 2) **Detail of operation:** Input current to the converter is monitored with the current sensor fixed on the printed circuit board of the outdoor unit and, if the operation current value reaches the limiting current value, the compressor command speed is reduced.
If the mechanism is actuated when the compressor command speed is less than 30 rps, the compressor is stopped immediately. Operation starts again after a delay time of 3 minutes.

(j) **Current cut**

- 1) **Purpose:** Inverter is protected from overcurrent.
- 2) **Detail of operation:** Output current from the inverter is monitored with a shunt resistor and, if the current exceeds the setting value, the compressor is stopped immediately. Operation starts again after a delay time of 3 minutes.

(k) **Outdoor unit failure**

This is a function for determining when there is trouble with the outdoor unit during air conditioning.

The compressor is stopped if any one of the following in item 1), 2) is satisfied. Once the unit is stopped by this function, it is not restarted.

- 1) When the input current is measured at 1 A or less for 3 continuous minutes or more.
- 2) If the outdoor unit sends a 0 rps signal to the indoor unit 3 times or more within 20 minutes of the power being turned on.

(l) **Rotor lock**

If the motor for the compressor does not turn after it has been started, it is determined that a compressor lock has occurred and the compressor is stopped.

(m) **Outdoor fan motor protection**

If the outdoor fan motor has operated at 75 rpm or under for more than 30 seconds, the compressor and fan motor are stopped.

(n) **Outdoor fan control at low outdoor temperature**

1) **Cooling**

- a) **Operating conditions:** When the outdoor air temperature (TH2) is 22°C or lower continues for 30 seconds while the compressor command speed is other than 0 rps.
- b) **Detail of operation:** After the outdoor fan operates at A speed for 60 seconds; the corresponding outdoor heat exchanger temperature shall implement the following controls.

• Value of A

	Outdoor fan
Outdoor temperature > 10°C	2nd speed
Outdoor temperature ≤ 10°C	1st speed

- i) Outdoor heat exchanger temperature ≤ 21°C
After the outdoor fan speed drops (down) to 1 speed for 60 seconds; if the outdoor heat exchanger temperature is lower than 21°C, gradually reduce the outdoor fan speed by 1 speed. (Lower limit 1st speed)
 - ii) 21°C < Outdoor heat exchanger temperature ≤ 38°C
After the outdoor fan speed maintains at A speed for 20 seconds; if the outdoor heat exchanger temperature is 21°C ~ 38°C, maintain outdoor fan speed.
 - iii) Outdoor heat exchanger temperature > 38°C
After the outdoor fan speed rises (up) to 1 speed for 60 seconds; if the outdoor heat exchanger temperature is higher than 38°C, gradually increase outdoor fan speed by 1 speed. (Upper limit 3rd speed)
- c) **Reset conditions:** When either of the following conditions is satisfied
- i) The outdoor air temperature (TH2) is 25°C or higher.
 - ii) The compressor command speed is 0 rps.
- 2) **Heating**
- a) **Operating conditions:** When the outdoor air temperature (TH2) is 4°C or lower continues for 30 seconds while the compressor command speed is other than 0 rps.
 - b) **Detail of operation:** The outdoor fan is stepped up by 2 speed step at each 20 seconds. (Upper limit 8th speed)
 - c) **Reset conditions:** When either of the following conditions is satisfied
- i) The outdoor air temperature (TH2) is 6°C or higher.
 - ii) The compressor command speed is 0 rps.

(II) FDC 71 ~ 250 models**(a) Determination of compressor speed (frequency)****Required frequency**

1) Cooling/dehumidifying operation

Unit: rps

Model		71	100	125	140	200	250
Max. required frequency	Indoor unit air flow “P-Hi”, “Hi”	88	90	105	105	100	120
	Indoor unit air flow “Me”, “Lo”	76	60	80	85	70	80
Min. required frequency		20	20	20	20	30	30

2) Heating operation

Unit: rps

Model		71	100	125	140	200	250
Max. required frequency	Indoor unit air flow “P-Hi”, “Hi”	95	90	105	110	100	120
	Indoor unit air flow “Me”, “Lo”	86	60	80	85	70	80
Min. required frequency		20	20	20	20	30	30

3) If “Silent mode start” signal is received from the remote controller, the maximum required frequency becomes same as when the indoor air flow is set at “Lo”.

4) Max. required frequency under high outdoor air temperature in cooling mode

Maximum required frequency is selected according to the outdoor air temperature (Tho-A).

Unit: rps

Model		71	100	125	140	200	250
Max. required frequency	Outdoor air temperature is 40°C or higher	76	75	90	96	75	98
	Outdoor air temperature is 46°C or higher	60	75	75	75	66	66

5) Max. required frequency under outdoor air temperature in heating mode

Maximum required frequency is selected according to the outdoor air temperature (Tho-A).

Unit: rps

Model		71	100	125	140	200	250
Max. required frequency	Outdoor air temperature is 18°C or higher	74	60	80	85	70	80

6) Selection of max. required frequency by heat exchanger temperature

1) Maximum required frequency is selected according to the outdoor unit heat exchanger temperature (Tho-R) during cooling/dehumidifying or according to the indoor unit heat exchanger temperature (Thi-R) during heating mode.

2) When there are 3 indoor unit heat exchanger temperatures (Thi-R), whichever the highest applies,

Unit: rps

Model			71	100	125	140	200	250
Max. required frequency	Cooling/dehumidifying	Outdoor unit heat exchanger temperature is 56°C or higher	–	–	100	100	–	–
	Heating	Indoor unit heat exchanger temperature is 56°C or higher	–	–	100	100	–	–

7) When any of the controls from 1) to 6) above may duplicate, whichever the smallest value among duplicated controls is taken as the maximum required frequency.

8) During heating, it is operated with the maximum required frequency until the indoor unit heat exchanger temperature becomes 40°C or higher.

(b) Compressor start control

1) Compressor starts upon receipt of the thermostat ON signal from the indoor unit.

2) However, at initial start after turning the power supply breaker, it may enter the standby state for maximum 30 minutes (“ PREPARATION” is displayed on the remote controller) in order to prevent the oil loss in the compressor.

If the cooling/dehumidifying/heating operation is selected from the remote controller when the outdoor unit is in the standby state, “ PREPARATION” is displayed for 3 seconds on the remote controller.

(c) Compressor soft start control

1) Compressor protection start I

[Control condition] Normally, the compressor operation frequency is raised in this start pattern.

[Control contents] a) Starts with the compressor's target frequency at **A** rps.

However, when the ambient air temperature (Tho-A) is 35°C or higher during cooling/dehumidifying or the indoor return air temperature (Thi-A) is 25°C or higher during heating, it starts at **C** rps.

b) At 30 seconds after the start of compressor, its target frequency changes to **B** rps and the compressor is operated for 2 - 4 minutes with its operation frequency fixed at **B** rps.

Model	Operation mode	A rps	B rps	C rps
71	Cooling/Dehumidifying	42	42	40
	Heating	62	62	40
100~140	Cooling/Dehumidifying	55	55	30
	Heating	55	55	30
200, 250	Cooling/Dehumidifying	55	55	30
	Heating	55	55	30

2) Compressor protection start III

[Control condition] Number of compressor starts is only 1 counted after the power supply breaker ON.

[Control contents] Operates by selecting one of following start patterns according to the operation mode and the outdoor air temperature (Tho-A).

a) Low frequency operation control during cooling/dehumidifying

[Control condition] Upon establishing the conditions of compressor protection start III, the low frequency operation control is performed during cooling/dehumidifying.

[Control contents] ① Starts with the compressor's target frequency at **A** rps. When the outdoor air temperature (Tho-A) is 35°C or higher, it starts at **C** rps.

② At 30 seconds after the compressor start, the compressor's target frequency is changed to **B** rps and the compressor's operation frequency is fixed for 10 minutes.

Model	Operation mode	A rps	B rps	C rps
71	Cooling/Dehumidifying	20	20	20
100~140	Cooling/Dehumidifying	55	55	30
200, 250	Cooling/Dehumidifying	55	30	30

b) Low frequency operation control during heating

[Control condition] When the conditions of compressor protection start III are established and one of following conditions ① and ② is satisfied, the low number of revolutions operation control is performed during heating.

① At 30 minutes or more after turning the power supply breaker on

② Compressor underneath temperature (Tho-H) is 4°C or higher and the difference from the outdoor air temperature (Tho-A) becomes 4°C or higher. [model 200, 250 only]

[Control contents] ① Starts the compressor with its target frequency at **A** rps. However, when the indoor unit return air temperature (Thi-A) is 25°C or higher, it start at **C** rps.

② At 30 seconds after the start of compressor, the compressor's target frequency is changed to **B** rps and the compressor's operation frequency is fixed for 10 minutes.

Model	Operation mode	A rps	B rps	C rps
71	Heating	42	42	40
100~140	Heating	55	55	30
200, 250	Heating	55	30	30

(d) Outdoor unit fan control

1) Outdoor unit fan tap and fan motor speed

Unit: min⁻¹

Model	Mode	Fan motor tap						
		① speed	② speed	③ speed	④ speed	⑤ speed	⑥ speed	⑦ speed
71	Cooling/Dehumidifying	200	400	600	710	850	850	950
	Heating	200	400	600	710	850	850	950
100~140	Cooling/Dehumidifying	200	350	600	740	820	870	910 (950) ⁽²⁾
	Heating	200	350	600	740	820	870	910 (950) ⁽²⁾
200, 250	Cooling/Dehumidifying	200	370	560 (600) ⁽³⁾	820	850	910	950
	Heating	200	370	560 (600) ⁽³⁾	820	850	910	950

Notes(1) Fan motor speed for model 200 and 250 are same for both top and bottom lines.

(2) Value in () are for the model 125, 140.

(3) Value in () are for the model 250.

2) Fan tap control during Cooling/Defumidifying operation

Fan taps are selected depending on the outdoor unit heat exchanger temperature (Tho-R1, R2) and the outdoor air temperature (Tho-A).

Note (1) It is detected by Tho-R1 or R2, whichever the higher.

• Model 71 ~ 140

	A zone	B zone	C zone	D zone
a zone	Tap 5	Tap 5(6) ⁽²⁾	Tap 5	Tap 4
b zone	Tap 5	Tap 5	Tap 4 ⁽³⁾	Tap 3
c zone	Tap 4	Tap 4 ⁽³⁾	Tap 3	Tap 2
d zone	Tap 3	Tap 3	Tap 2	Tap 1

• Model 200, 250

	A zone	B zone	C zone	D zone
a zone	Tap 5	Tap 5	Tap 5	Tap 4
b zone	Tap 5	Tap 5	Tap 4 ⁽³⁾	Tap 3
c zone	Tap 4	Tap 4 ⁽³⁾	Tap 3	Tap 2
d zone	Tap 3	Tap 3	Tap 2	Tap 1

Notes (1) Value in () is for the model 71.

(2) In silent mode, the fan tap is shifted from "Tap 6" to "Tap 5" for the model 71.

(3) In silent mode, the fan taps are shifted from "Tap 4" to "Tap 3" for all models except the model 71.

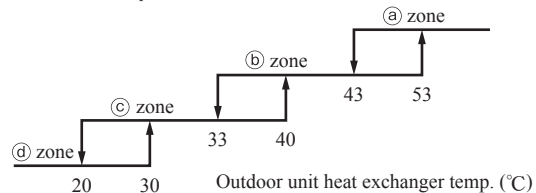
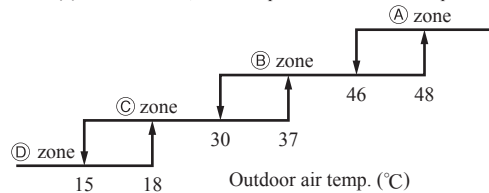

3) Fan tap control during heating operation

Fan taps are selected depending on the outdoor unit heat exchanger temperature (Tho-R1, R2) and the outdoor air temperature (Tho-A).

Note (1) It is detected by Tho-R1 or R2, whichever the lower.

• Model 71 ~ 140

	A zone	B zone	C zone
a zone	Tap 3	Tap 3	Tap 4 ⁽¹⁾
b zone	Tap 3	Tap 4 ⁽¹⁾	Tap 5
c zone	Tap 4	Tap 5	Tap 6

• Model 200, 250

	A zone	B zone	C zone
a zone	Tap 3	Tap 3	Tap 4 ⁽¹⁾
b zone	Tap 3	Tap 4 ⁽¹⁾	Tap 5
c zone	Tap 4	Tap 5	Tap 6

Note (1) In silent mode, the fan taps are shifted from "Tap 4" to "Tap 3" for all models.

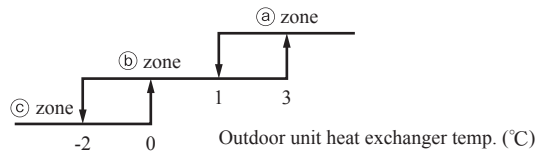
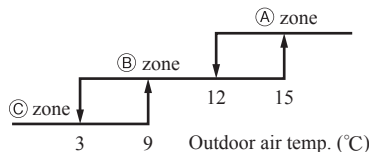

4) Outdoor unit fan control at cooling low outdoor air

a) When all the following conditions are established after the start of compressor, the following control is implemented.

If the outdoor air temperature (Tho-A) is in the zone (B) in the cooling/dehumidifying mode, it has elapsed 20 seconds from the start of outdoor unit fan and the outdoor unit fan is at the tap 1 speed, the outdoor unit fan speed is controlled according to the outdoor unit heat exchanger temperature (Tho-R1, R2).

Note (1) It is detected with Tho-R1 or R2, whichever the higher.

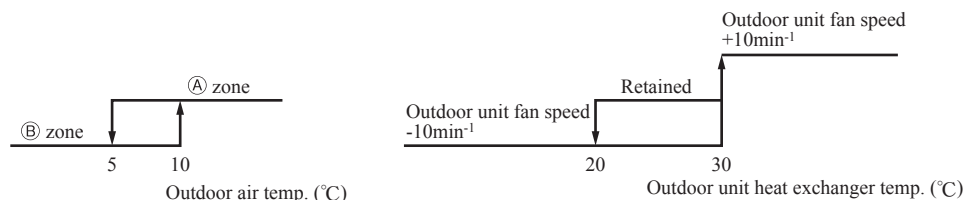

Note (1) In silent mode, the fan taps are shifted from "Tap 4" to "Tap 3" for all models.

- b) The outdoor unit heat exchanger temperature is detected always and, when the number of revolutions of the outdoor fan speed has been increased or decreased, there is no change of fan speed for 20 seconds.
- c) Range of the outdoor unit fan speed under this control is as follows.
 - ① Lower limit: 130rpm
 - ② Upper limit: 500rpm
- d) As any of the following conditions is established, this control terminates.
 - i) When the outdoor air temperature is in the zone ① and the outdoor unit heat exchanger temperature at 30°C or higher is established for 40 seconds or more continuously.
 - ii) When the outdoor fan speed is 500rpm and the outdoor unit heat exchanger temperature at 30°C or higher is established for 40 seconds or more continuously.
 - iii) When the outdoor unit heat changer temperature at 45°C or higher is established for 40 seconds or more.

5) Outdoor unit fan control by the power transistor radiator fin temperature

When all the following conditions are established later than 3 minutes after the start of compressor, the following control is implemented.

- a) Cooling/dehumidifying
 - ① Outdoor air temperature $Tho-A \geq 33^\circ C$
 - ② Compressor's actual frequency $\geq A$ rps
 - ③ Power transistor radiator fin temperature $\geq C$ °C
- b) Heating
 - ① Outdoor air temperature $Tho-A \geq 16^\circ C$
 - ② Compressor's actual frequency $\geq B$ rps
 - ③ Power transistor radiator fin temperature $\geq C$ °C
- c) Control contents
 - i) Raises the outdoor unit fan tap by 1 tap.
 - ii) When the sampling is for 60 minutes and the value of power transistor radiator fin temperature (Tho-P) is as follows.
 - ① When the power transistor radiator fin temperature (Tho-P) $\geq C$ °C, the outdoor unit fan tap is raised by 1 speed further.
 - ② When C °C > power transistor radiator fin temperature (Tho-P) $\geq D$ °C, present outdoor unit fan tap is maintained.
 - ③ When the power transistor radiator fin temperature (Tho-P) $\geq D$ °C, the outdoor unit fan tap is dropped by 1 speed.
- d) Ending conditions

When the operation under the condition of item ii), ③ above and with the outdoor unit fan tap, which is determined by the item 2) is detected 2 times consecutively.

- Compressor's frequency and power transistor radiator fin temperature

Model \ Item	A	B	C	D
71	60	70	80	75
100~140	85	85	72	68
200, 250	70	70	80	75

6) Caution at the outdoor unit fan start control

When the outdoor unit fan is running at 400min⁻¹ before operating the compressor, it may operate with the compressor only, without starting up the outdoor fan This is normal.

7) Snow protection fan control

If the dip switch (SW3-2) on the outdoor unit control PCB is turned ON, the outdoor unit fan is operated for 30 seconds at 4 tap speed once in every 10 minutes depending on the outdoor air temperature (detected with Tho-A) in the stop mode or anomalous stop mode.

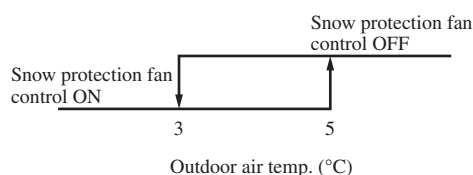

(e) Defrosting

1) Defrosting start conditions

If all of the following defrosting conditions A or conditions B are met, the defrosting operation starts.

a) Defrosting conditions A

- i) Cumulative compressor operation time after the end of defrosting has elapsed 37 [45] minutes, and the cumulative compressor operation time after the start of heating operation (remote controller ON) has elapsed 30 minutes.
- ii) After 5 minutes from the compressor ON
- iii) After 5 minutes from the start of outdoor unit fan
- iv) After satisfying all above conditions, if temperatures of the outdoor unit heat exchanger temperature thermistor (Tho-R1, R2) and the outdoor air temperature thermistor (Tho-A) become lower than the defrosting start temperature as shown by the right figure for 15 seconds continuously, or the suction gas saturation temperature (SST) and the outdoor air temperature (Tho-A), which are obtained from the value detected by the low pressure sensor (LPT) stay for 3 minutes within the range below the defrosting operation start temperature as shown by the right figure. However, it excludes for 10 minutes after the start of compressor and the outdoor air temperature is as shown by the lower figure.

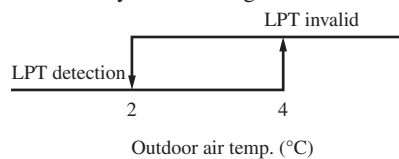

Note (1) Figures in [] are for model 71.

b) Defrosting conditions B

- i) When previous defrosting end condition is the time out of defrosting operation and it is in the heating operation after the cumulative compressor operation time after the end of defrosting has become 30 minutes.
- ii) After 5 minutes from the start of compressor
- iii) After 5 minutes from the start of outdoor unit fan

2) Defrosting end conditions

When any of the following conditions is satisfied, the defrosting end operation starts.

- a) When it has elapsed 8 minutes and 20 seconds after the start of defrosting. (After 10 minutes and 20 seconds for model 71, 200 and 280)
- b) When the outdoor unit heat exchanger temperatures (Tho-R1, R2), whichever the lower, becomes 12°C or higher for 10 seconds continuously.

Model 71 ~ 250

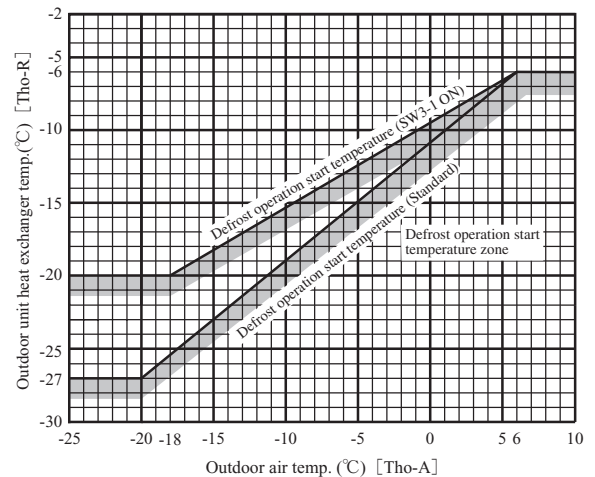

Model 71

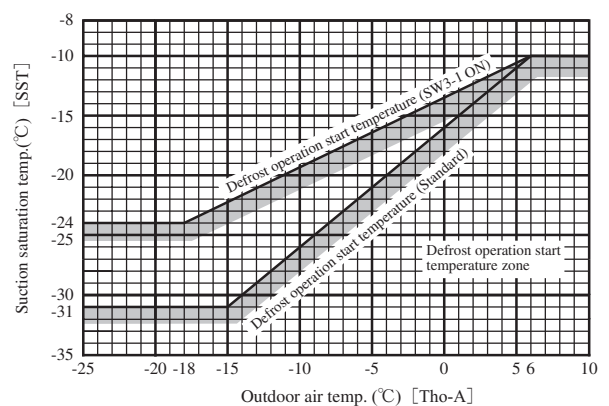

Model 100 ~ 250

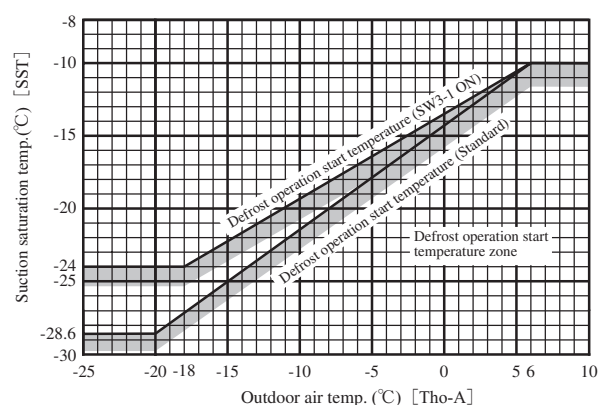

3) Switching of defrosting control with SW3-1

- a) If SW3-1 on the outdoor unit control PCB is turned to ON, it becomes easier to enter the defrosting operation. Use this when installing a unit at snowing regions.
- b) Control contents
 - i) It allows entering the defrosting operation under the defrosting condition A when the cumulative heating operation time becomes 30 minutes. It is 37 [45] minutes at SW3-1 OFF (Factory default).
 - ii) It allows entering the defrosting operation under the defrosting condition B when the cumulative heating operation time becomes 25 minutes. It is 30 minutes at SW3-1 OFF (Factory default).
 - iii) It allows the defrosting operation with the outdoor unit heat exchanger temperature (Tho-R) and suction pressure saturation temperature (SST) being higher than normal.

Note (1) Figures in [] are for model 71.

(f) Protective control/anomalous stop control by compressor's number of revolutions

1) Compressor discharge pipe temperature protection

- a) Protective control

As the discharge pipe temperature (detected with Tho-D) exceeds the setting value, the compressor speed (frequency) is controlled to suppress the rise of discharge pipe temperature.

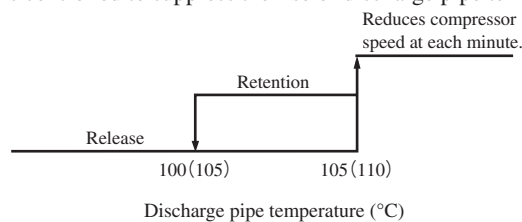

Note (1) Value in () are for the model 200, 250.

- b) Anomalous stop control

- i) If the discharge pipe temperature (detected with Tho-D) exceeds the setting value, the compressor stops.
- ii) When it is detected 2 times within 60 minutes or after continuous 60 minutes, including the stop of compressor, E36 is displayed on the remote controller and it enters the anomalous stop mode.

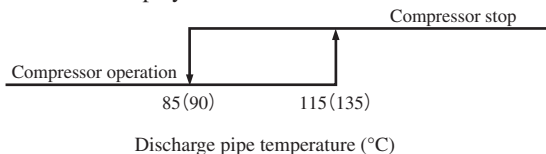

Note (1) Value in () are for the model 200, 250.

- c) Reset of anomalous stop mode

As it drops to the reset value of 85°C (90°C) or lower for 45 minutes continuously, it becomes possible to restart from the remote controller.

Note (1) Value in () are for the model 200, 250.

2) Cooling high pressure protection

- a) Protective control

- i) When the outdoor air temperature (Tho-A) is 40°C or higher and the outdoor unit heat exchanger temperature (Tho-R) exceeds the setting value, the compressor speed (frequency) is controlled to suppress the rise of high pressure.
- ii) Control value A is updated to an optimum value automatically according to the operating conditions.

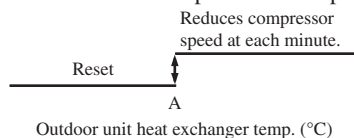

Control value A
54~60°C

- b) Anomalous stop control

- i) As the outdoor unit heat exchanger temperature (Tho-R) exceeds the setting value, the compressor stops.
- ii) If it is detected 5 times within 60 minutes or 65°C or higher continues for 60 minutes, including the stop of compressor, E35 is displayed on the remote controller and it enters the anomalous stop mode.

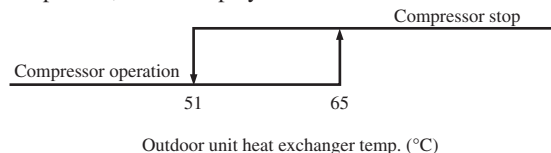

- c) Reset of anomalous stop mode

As it reaches the reset value of 51°C or lower, it becomes possible to restart from the remote controller.

3) Heating high pressure protection

- a) Protective control
 - i) As the indoor unit heat exchanger temperature (Thi-R) exceeds the setting value, the compressor speed (frequency) is controlled to suppress the rise of high pressure.
 - ii) Control value A is updated to an optimum value automatically according to the operating conditions.

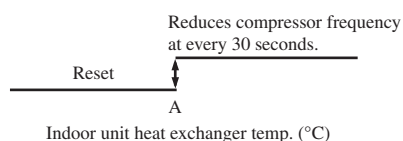

Model	Existing piping adaptation switch: SW5-1 (SW8-1: model 80)	
	OFF (Shipping)	ON
	Control value A (°C)	
71	52~58	46~52
100~140	48~54	
200, 250	52~58	

Note (1) Adaptation to existing piping is at ON.

- b) Anomalous stop control
Operation control function by the indoor unit controller - See the heating overload protection, page 10.
- c) Adaptation to existing piping, stop control
If the existing piping adaptation switch, SW5-1 (SW8-1: 71 type), is turned ON, the compressor stops to protect existing piping when the indoor unit heat exchanger temperature (Thi-R) exceeds the setting value.

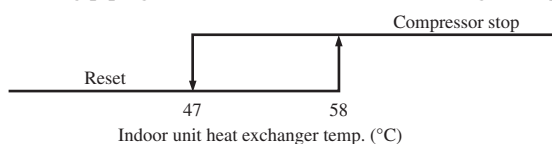

4) Anomaly detection control by the high pressure switch (63H1)

- a) If the pressure rises and operates the high pressure switch (opens at 4.15MPa/closes at 3.15MPa), the compressor stops.
- b) Under any of the following conditions, E40 is displayed and it enters the anomalous stop mode.
 - ① When it occurs 5 times within 60 minutes that pressure rises and the compressor is stopped by 63H1.
 - ② When 63H1 has been in the open state for 60 minutes continuously, including the stop of compressor.

5) Low pressure control

- a) Protective control
If the value detected by the low pressure sensor (LPT) exceeds the setting value, the compressor speed (frequency) is controlled to restrain the drop of pressure.

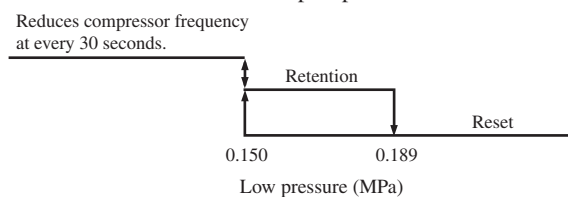

- b) Anomalous stop control
 - i) When a value detected by the low pressure sensor (LPT) satisfies any of the following conditions, the compressor stops to run for its protection.
 - ① When the low pressure drops to 0.079MPa or under for 15 seconds continuously.
 - ② At 10 minutes after the start of compressor, the suction overheat becomes 30°C and the low pressure becomes 0.15MPa or under for 60 seconds continuously.
 - ii) E49 is displayed under any of the following conditions and it enters the anomalous stop mode.
 - a) When the low pressure drops 3 times within 60 minutes and the compressor stops under any of the above conditions.
 - b) When a value detected with the low pressure sensor becomes 0.079MPa or under for 5 minutes, including the stop of compressor.
 - iii) However, when the control condition ① is established during the compressor protection start III, E49 is displayed at initial stop and it enters the anomalous stop mode.

6) Compressor pressure ratio protection control

- a) During heating operation, if the indoor unit heat exchanger temperature (Thi-R) and the outdoor unit heat exchanger temperature (Tho-R) exceed the setting values at 10 minutes after the start of compressor, the compressor speed (frequency) is controlled to protect the compressor.
- b) This control is not performed during the outdoor fan ON and for 10 minutes from the start of outdoor unit fan.
- c) This control is not performed during defrosting operation and at 10 minutes after the reset of defrosting operation.
- d) When there are 3 indoor unit heat exchanger temperatures (Thi-R), the highest temperature is detected.

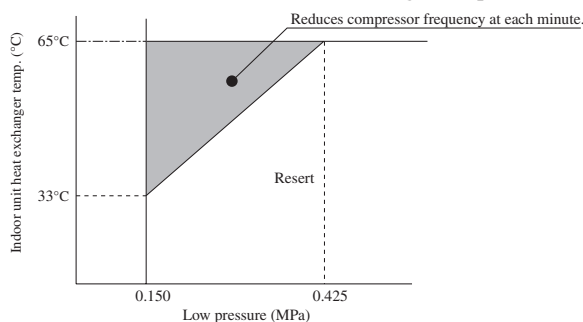

7) Over-current protection current safe controls I, II

Detecting the outdoor unit inverter input (primary) current and the output (secondary) current, if the current values exceed setting values, the compressor speed (frequency) is controlled to protect the inverter.

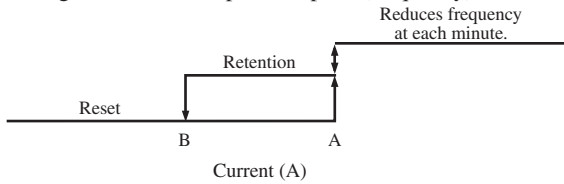

(Fig. C) The control value "A" and the reset value vary depending on the compressor speed.

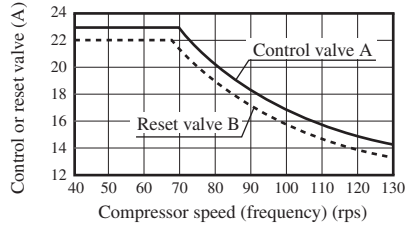

Model	Cooling		Heating		
	Control value A	Reset value B	Control value A	Reset value B	
Primary current side	71	15.0	14.0	16.0	15.0
	100	13.5 (23.0)	12.5 (22.0)	13.5 (23.0)	12.5 (22.0)
	125, 140	13.5 (23.0)	12.5 (22.0)	13.5 (23.0)	12.5 (22.0)
	200	17.0	16.0	17.0	16.0
	250	20.0	19.0	20.0	19.0
Secondary current side	71	13.0	12.0	13.0	12.0
	100	13.0 (Fig.C)	12.0 (Fig.C)	13.0 (Fig.C)	12.0 (Fig.C)
	125, 140	13.0 (Fig.C)	12.0 (Fig.C)	13.0 (Fig.C)	12.0 (Fig.C)
	200	Not implemented			
	250	Not implemented			

Note (1) Value in () are for the single phase models.

8) Power transistor temperature protection

a) Protective control

If the power transistor temperature (detected with TIP) exceeds the setting value, the compressor speed (frequency) is controlled to suppress the rise of power transistor temperature.

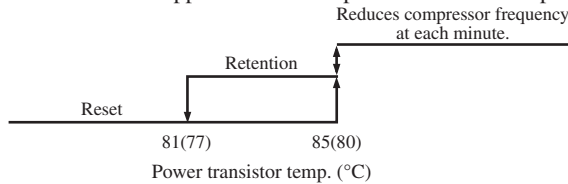

Note (1) Value in () are for the single phase model 100~140.

b) Anomalous stop control (model 200, 250 only)

i) If the power transistor temperature rises further, the protective switch in the power transistor operates to protect the compressor and the power transistor.

ii) Under any of the following condition, E41 is displayed and it enters the anomalous stop mode.

① When the protective switch in the power transistor operates 5 times within 60 minutes and the compressor stops.

9) Anomalous power transistor current

a) Prevents over-current on the inverter. If the current value in the power transistor exceeds the setting value, the compressor stops.

b) If the current value in the power transistor exceeds the specified value and the compressor stops 4 times within 30 minutes, E42 is displayed on the remote controller and it enters the anomalous stop mode.

10) Anomalous inverter PCB

If the power transistor detects any anomaly for 15 minutes, including the stop of compressor, E51 is displayed on the remote controller and it enters the anomalous stop mode.

11) Anti-frost control by the compressor frequency control

a) If the indoor unit heat exchanger temperature (detected with Th-R) exceeds the setting value at 4 minutes after the start of compressor, the compressor speed (frequency) is controlled to initiate the anti-frost control of indoor unit heat exchanger.

b) When there are 3 indoor unit heat exchanger temperatures (Th-R), the lowest temperature is detected.

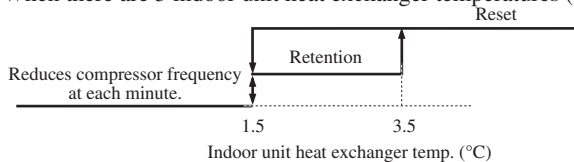

c) Regarding the anti-frost control by the operation stop, refer to the operation control function by the indoor unit controller and the cooling, dehumidifying frost prevention of page 10.

12) Dewing prevention control

[Control condition] During cooling and dehumidifying operation, if all the following conditions are established, the compressor speed (frequency) is reduced to prevent dewing and water splash.

- ① Cooling electronic expansion valve aperture (EEVC) is 500 pulses.
- ② Suction overheat is 10°C or higher.
- ③ Compressor speed (frequency) is **A** rps or higher.

[Control contents] ① When the suction overheat is 10°C or higher, the compressor speed (frequency) is reduced at each 1 minute.

② Compressor speed (frequency) does not rise till the cooling expansion valve becomes 460 pulses.

③ This control takes **A** rps as its lower limit so that compressor speed is not controlled when it is less than **A** rps.

Model	A rps
71	42
100~140	60
200, 250	60

13) Refrigerant quantity shortage protection

Under the compressor protection start III control during cooling and dehumidifying operations, the following control is performed by detecting the indoor unit heat exchanger temperature (Thi-R) and the indoor unit return air temperature (Thi-A).

[Control condition] When the state that the indoor unit heat exchanger temperature (Thi-R) does not become lower than the indoor unit return air temperature (Thi-A) by 4°C or more continues for 1 minute.

[Control contents] It judges that the flowing of refrigerant in to the indoor unit is insufficient so that the compressor is stopped and E57 is displayed on the remote controller.

14) Broken wire detection on temperature thermistor and low pressure sensor

a) Outdoor unit heat exchanger thermistor, outdoor air thermistor and low pressure sensor

If the following is detected for 5 second continuously within 2 minutes to 2 minutes and 20 seconds after the compressor ON, the compressor stops. After a delay of 3 minutes, it restarts but, if the same is detected repeatedly 3 times within 40 minutes, the compressor stops with the anomalous stop.

Note (1) During defrosting and for 3 minutes after the end of defrosting, it is not detected.

- Outdoor unit heat exchanger thermistor: -50°C or lower
- Outdoor air temperature thermistor: -45 or lower
- Low pressure sensor: 0V or under or 3.49V or over

b) Discharge pipe temperature thermistor, suction pipe temperature thermistor and underneath temperature thermistor (model 200, 250 only)

If the following is detected for 5 second continuously within 10 minutes to 10 minutes and 20 seconds after the compressor ON, the compressor stops. After a delay of 3 minutes, it restarts but, if the same is detected repeatedly 3 times within 40 minutes, the compressor stops with the anomalous stop.

Note (1) During defrosting and for 3 minutes after the end of defrosting, it is not detected.

- Discharge pipe temperature thermistor: -10°C or lower
- Suction pipe temperature thermistor: -50 or lower
- Underneath temperature thermistor: -50°C or lower

15) Open phase protection (3-phase models only)

When 0V is detected on any of L1, L2 or L3 phase for 5 seconds continuously after the power ON, it judges the state of open phase on the power supply and activates the anomalous stop (E34) 1 second later.

16) Fan motor error

a) If the fan speed of 100rpm or under is detected for 30 second continuously under the outdoor unit fan control (with the operation command of fan tap at ① speed or higher), the compressor stops.

b) When the fan motor speed drops to 100rpm or under 5 times within 60 minutes and the compressor stops, it enters the anomalous stop mode with E48 displayed on the remote controller.

17) Anomalous stop by the compressor start stop

1) When it fails to shift to the compressor DC motor's rotor position defection operation at 5 seconds after establishing the compressor start condition, the compressor stops temporarily and restarts 3 minutes later.

2) If it fails to shift to the position detection operation again at second time, it judges the anomalous compressor start and stops the compressor by the anomalous stop (E59).

18) Anomalous compressor rotor lock (model 200, 250 only)

After shifting to the compressor rotor's position detection operation, if fails again to detect the rotor position, the compressor stops.

Compressor restarts 3 minutes later but, if it is operated 4 times within 15 minutes, the anomalous stop (E60) occurs.

(g) Silent mode

- 1) As “Silent mode start” signal is received from the remote controller, it operates by dropping the outdoor unit fan tap and the compressor speed (frequency).
- 2) For details, refer to items (a) and (d) above.

(h) Test run

1) It is possible to operate from the outdoor unit using the dip switch on the outdoor unit control PCB.

SW3-3 (SW5-3)	ON	SW3-4 (SW5-4)	OFF	Cooling test run
			ON	Heating test run
	OFF	Normal and end of test run		

Make sure to turn SW3-3 (SW5-3) to OFF after the end of operation.

Note (1) Value in () are for the model 71.

2) Test run control

- a) Operation is performed at the maximum compressor speed (frequency), which is determined for each model.
- b) Each protective control and error detection control are effective.
- c) If SW3-4 (SW5-4) is switched during test run, the compressor is stopped for once by the stop control and the cooling/heating operation is switched.
Note (1) Value in () are for the model 71.
- d) Setting and display of remote controller during test run

Mode \ Item	Contents of remote controller setting/display
Cooling test run	Setting temperature of cooling is 5°C.
Heating test run	Setting temperature of heating (preparation) is 30°C.

(i) Pump-down control

Turning ON the pump-down switch SW1 (SW9) for 2 seconds during the operation stop or anomalous stop (excluding the thermostat OFF), the pump-down operation is performed. (This is invalid when the indoor unit is operating. This is effective even when the indoor unit is stopped by the anomalous stop or the power supply is turned OFF.)

Note (1) Value in () are for the model 71.

1) Control contents

- a) Close the operation valve at the liquid side. (It is left open at the gas side.)
- b) Compressor is started with the target speed (frequency) at 55 (62) rps in the cooling mode.
Note (1) Value in () are for the model 71.
- c) Red and green lamps (LED) flash continuously on the outdoor unit control PCB.
- d) Each of protection and error detection controls, excluding the low pressure control, anti-frost control and dewing prevention control, is effective.
- e) Outdoor unit fan is controlled as usual.
- f) Electronic expansion valve is fully opened.
- g) Solenoid valve (SV1) of model 71 is fully opened during the control.

2) Control ending conditions

Stop control is initiated depending on any of the following conditions.

- a) Low pressure of 0.087MPa or lower is detected for 5 seconds continuously.
 - i) Red LED: Light, Green LED: Flashing, Remote controller: Displays stop.
 - ii) It is possible to restart when the low pressure is 0.087MPa or higher.
 - iii) Electronic expansion valve (cooling/heating) is kept fully open.
- b) Stop by the error detection control
 - i) Red LED: Flashing, Green LED: Flashing
 - ii) Restart is prohibited. To return to normal operation, reset the power supply.
 - iii) Electronic expansion valve (cooling/heating) is left fully open.
- c) When the cumulative operation time of compressor under the pump-down control becomes 5 minutes.
 - i) Red LED: OFF, Green LED: Flashing, Remote controller: Stop
 - ii) It is possible to pump-down again.
 - iii) Electronic expansion valve (cooling/heating) is left fully open.

Note (1) After the stop of compressor, close the operation valve at the gas side.

Caution: Since pressing the pump-down switch cancels communications with the indoor unit, the indoor unit and the remote controller display “Transmission error – E5”. This is normal.

(j) Drain pan ON/OFF output control (optional) (Models 100 ~ 250 only)**1) Drain pan heater ON conditions**

When all of following conditions are met, the drain pan heater is turned ON.

- Outdoor air temperature (detected with Tho-A) is 3°C or lower.
- In the heating mode
- When the compressor is turned ON

2) Drain pan heater OFF conditions

When either one of following conditions is met, the drain pan heater is turned OFF.

- Outdoor air temperature (detected with Tho-A) is 5°C or higher.
- When the compressor stop has been detected for 30 minutes continuously
- In the cooling or dehumidifying mode

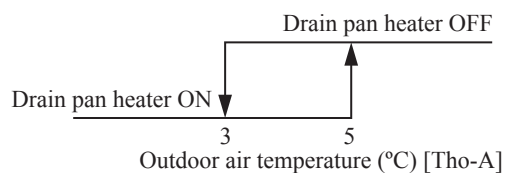

2. MAINTENANCE DATA

2.1 Diagnosing of microcomputer circuit

(1) Selfdiagnosis function

(a) Check Indicator Table

Whether a failure exists or not on the indoor unit and outdoor unit can be know by the contents of remote controller error code, indoor/outdoor unit green LED (power pilot lamp and microcomputer normality pilot lamp) or red LED (check pilot lamp).

(i) Indoor unit

Remote controller		Indoor control PCB		Outdoor control PCB		Location of trouble	Description of trouble	Repair method	Reference page
Error code	Red LED	Red LED	Green LED (1)	Red LED	Green LED (1)				
No-indication	Stays OFF	Stays OFF	Keeps flashing	Stays OFF	Keeps flashing	—	• Normal operation	—	—
		Stays OFF	Stays OFF	2 times flash	Stays OFF	Indoor unit power supply	• Power OFF, broken wire/blown fuse, broken transformer wire	Repair	68
		* 3 times flash	Keeps flashing	Stays OFF	Keeps flashing	Remote controller wires	• Poor connection, breakage of remote controller wire * For wire breaking at power ON, the LED is OFF.	Repair	69
				Remote controller	• Defective remote controller PCB	Replacement of remote controller			
WAIT or INSPECT I/U		Stays OFF	Keeps flashing	2 times flash	Keeps flashing	Indoor-outdoor units connection wire	• Poor connection, breakage of indoor-outdoor units connection wire	Repair	70 ~ 77
						Remote controller	• Improper setting of master and slave by remote controller		
E1	Keeps flashing	Stays OFF	* Keeps flashing	Stays OFF	Keeps flashing	Remote controller wires (Noise)	• Poor connection of remote controller signal wire (White) * For wire breaking at power ON, the LED is OFF	Repair	79
						Remote controller indoor control PCB	• Intrusion of noise in remote controller wire * Defective remote controller or indoor control PCB (defective communication circuit)?	Replacement of remote controller or PCB	
E5	Keeps flashing	2 times flash	Keeps flashing	2(6) times flash	Keeps flashing	Indoor-outdoor units connection wire	• Poor connection of wire between indoor-outdoor units during operation (disconnection, loose connection)	Repair	80
		2 times flash	Keeps flashing	Stays OFF	Keeps flashing	(Noise)	• Anomalous communication between indoor-outdoor units by noise, etc.	Power reset or Repair	
		2 times flash	Keeps flashing	Stays OFF	Stays OFF	Outdoor control PCB	• CPU-runaway on outdoor control PCB * Occurrence of defective outdoor control PCB on the way of power supply (defective communication circuit)?	Replacement of PCB	
E6	Keeps flashing	1 time flash	Keeps flashing	Stays OFF	Keeps flashing	Indoor heat exchanger temperature thermistor	• Defective indoor heat exchanger temperature thermistor(defective element, broken wire, short-circuit)	Replacement, repair of temperature thermistor	81
						Indoor control PCB	• Poor contact of temperature thermistor connector * Defective indoor control PCB (Defective temperature thermistor input circuit)?		
E7	Keeps flashing	1 time flash	Keeps flashing	Stays OFF	Keeps flashing	Indoor return air temperature thermistor	• Defective indoor return air temperature thermistor(defective element, broken wire, short-circuit)	Replacement, repair of temperature thermistor	82
						Indoor control PCB	• Poor contact of temperature thermistor connector * Defective indoor control PCB (Defective temperature thermistor input circuit)?		
E8	Keeps flashing	1 time flash	Keeps flashing	Stays OFF	Keeps flashing	Installation or operating condition	• Heating over-load (Anomalously high indoor heat exchanger temperature)	Repair	83
						Indoor heat exchanger temperature thermistor	• Defective indoor heat exchanger temperature thermistor (short-circuit)	Replacement of temperature thermistor	
						Indoor control PCB	* Defective indoor control PCB (Defective temperature thermistor input circuit)?	Replacement of PCB	
E9	Keeps flashing	1 time flash	Keeps flashing	Stays OFF	Keeps flashing	Drain trouble	• Defective drain pump (DM), broken drain pump wire, disconnected connector	Replacement, repair of DM	84
						Float switch	• Anomalous float switch operation (malfunction)	Repair	
						Indoor control PCB	* Defective indoor control PCB (Defective float switch input circuit)	Replacement of PCB	
						Option	* Defective indoor control PCB (Defective DM drive output circuit)?		
E10	Keeps flashing	Stays OFF	Keeps flashing	Number of connected indoor units	• When multi-unit control by remote controller is performed, the number of units is over	Repair	85		
E14	Keeps flashing	3 times flash	Stays OFF	Keeps flashing	Indoor unit No. setting	• No master is assigned to slaves.	Repair	86	
					Remote controller wires	• Anomalous remote controller wire connection, broken wire between master and slave units			
E16	Keeps flashing	Stays OFF	Stays OFF	Keeps flashing	Fan motor	• Defective fan motor	Replacement, repair	87	
					Indoor control PCB	• Defective indoor control PCB (In case of FDTC, FDT)	Replacement		
E19	Keeps flashing	1 time flash	Stays OFF	Keeps flashing	Indoor control PCB	• Improper operation mode setting	Repair	88	
E28	Keeps flashing	Stays OFF	Stays OFF	Keeps flashing	Remote controller temperature thermistor	• Broken wire of remote controller temperature thermistor	Repair	89	

Note (1) Normal indicator lamp (Indoor, outdoor units: Green) extinguishes (or lights continuously) only when CPU is anomalous. It keeps flashing in any trouble other than anomalous CPU.

(2) * mark in the Description of trouble means that, in ordinary diagnosis, it cannot identify the cause definitely, and, if the trouble is repaired by replacing the part, it is judged consequently that the replaced part was defective.

(3) Value in [] are for the model SRC40 ~ 60.

(ii) Outdoor unit

1) Models SRC40~60

Remote controller		Indoor control PCB		Outdoor control PCB		Location of trouble	Description of trouble	Repair method	Reference page
Error code	Red LED	Red LED	Green LED	Red LED	Red LED				
E35		Stays OFF	Keeps flashing	2 times flash	Installation, operation status	• Higher outdoor heat exchanger temperature	Repair	91	
					Outdoor heat exchanger temperature thermistor	• Defective outdoor heat exchanger temperature thermistor	Replacement, repair of temperature thermistor		
					Outdoor control PCB	*• Defective outdoor control PCB (Defective temperature sensor input circuit)?	Replacement of PCB		
E36		Stays OFF	Keeps flashing	5 times flash	Installation, operation status	• Higher discharge temperature	Repair	93	
					Discharge pipe temperature thermistor	• Defective discharge pipe temperature thermistor	Replacement, repair of temperature thermistor		
					Outdoor control PCB	*• Defective outdoor control PCB (Defective temperature sensor input circuit)?	Replacement of PCB		
E37		Stays OFF	Keeps flashing	8 times flash	Outdoor heat exchanger temperature thermistor	• Defective outdoor heat exchanger temperature thermistor, broken wire or poor connector connection	Replacement, repair of temperature thermistor	94	
					Outdoor control PCB	*• Defective outdoor control PCB (Defective temperature sensor input circuit)?	Replacement of PCB		
E38		Stays OFF	Keeps flashing	8 times flash	Outdoor air temperature thermistor	• Defective outdoor air temperature thermistor, broken wire or poor connector connection	Replacement, repair of temperature thermistor	95	
					Outdoor control PCB	*• Defective outdoor control PCB (Defective temperature sensor input circuit)?	Replacement of PCB		
E39	Keeps flashing	Stays OFF	Keeps flashing	8 times flash	Discharge pipe temperature thermistor	• Defective discharge pipe temperature thermistor, broken wire or poor connector connection	Replacement, repair of temperature thermistor	96	
					Outdoor control PCB	*• Defective outdoor control PCB (Defective temperature sensor input circuit)?	Replacement of PCB		
E42		Stays OFF	Keeps flashing	1 time flash	Outdoor control PCB compressor	• Current cut (Anomalous compressor over-current)	Replacement of PCB	99 • 100	
					Installation, operation status	• Service valve closing operation	Repair		
E47		Stays OFF	Keeps flashing	2 times flash	Outdoor control PCB power transistor	• Anomalous inverter over-voltage	Repair PCB replacement	102	
E48		Stays OFF	Keeps flashing	keeps flashing	Fan motor	• Defective fan motor	Replacement	103	
					Outdoor control PCB	• Defective outdoor control PCB			
E51		Stays OFF	Keeps flashing	1 time flash	Power transistor error (outdoor control / PCB)	• Power transistor error	Replacement of PCB	107	
E57		Stays OFF	Keeps flashing	2 times flash	Operation status	• Shortage in refrigerant quantity	Repair	112	
					Installation status	• Service valve closing operation	Service valve opening check		
E58		Stays OFF	Keeps flashing	3 times flash	• Overload operation • Overcharge • Compressor locking	• Current safe stop	Replacement	114	
E59		Stays OFF	Keeps flashing	2 times flash	Compressor outdoor control PCB	• Anomalous compressor startup	Replacement	115	
E60		Stays OFF	Keeps flashing	7 times flash	Compressor	• Anomalous compressor rotor lock	Replacement	117	

Note (1) * mark in the Description of trouble means that, in ordinary diagnosis, it cannot identify the cause definitely, and, if the trouble is repaired by replacing the part, it is judged consequently that the replaced part was defective.

2) Models FDC71~250

Remote controller		Indoor control PCB		Outdoor control PCB		Outdoor inverter PCB		Location of trouble	Description of trouble	Repair method	Reference page
Error code	Red LED	Red LED	Green LED (1)	Red LED	Green LED (1)	Yellow LED (3) or Red LED (4)	Green LED (2)				
E34		Stays OFF	Keeps flashing	1 time flash	Keeps flashing			Power supply wires	• Outdoor unit power supply L3-phase interruption, defective noise filter (3-phase model only)	Repair	90
								Outdoor control PCB	* Defective outdoor control PCB (Defective power supply input circuit)? (3-phase model only)	Replacement of PCB	
E35		Stays OFF	Keeps flashing	1 time flash	Keeps flashing			Installation or operating condition	• Higher outdoor heat exchanger temperature	Repair	92
								Outdoor heat exchanger temperature thermistor	• Defective outdoor heat exchanger temperature thermistor	Replacement of temperature thermistor	
E36		Stays OFF	Keeps flashing	1 time flash	Keeps flashing			Outdoor control PCB	* Defective outdoor control PCB (Defective temperature thermistor input circuit)?	Replacement of PCB	93
								Installation or operating condition	• Higher discharge temperature	Repair	
E37		Stays OFF	Keeps flashing	1 time flash	Keeps flashing			Discharge pipe temperature thermistor	• Defective discharge pipe temperature thermistor	Replacement, repair of temperature thermistor	94
								Outdoor heat exchanger temperature thermistor	• Defective outdoor heat exchanger temperature thermistor, broken wire or poor connector connection	Replacement, repair of temperature thermistor	
E38		Stays OFF	Keeps flashing	1 time flash	Keeps flashing			Outdoor control PCB	* Defective outdoor control PCB (Defective temperature thermistor input circuit)?	Replacement of PCB	95
								Outdoor air temperature thermistor	• Defective outdoor air temperature thermistor, broken wire or poor connector connection	Replacement, repair of temperature thermistor	
E39		Stays OFF	Keeps flashing	1 time flash	Keeps flashing			Outdoor control PCB	* Defective outdoor control PCB (Defective temperature thermistor input circuit)?	Replacement of PCB	96
								Discharge pipe temperature thermistor	• Defective discharge pipe temperature thermistor, broken wire or poor connector connection	Replacement, repair of temperature thermistor	
E40		Stays OFF	Keeps flashing	1 time flash	Keeps flashing			Installation or operating condition	• Rising high pressure (Operation of 63H1) • Service valve closing operation	Repair	97
								Outdoor control PCB	* Defective outdoor control PCB (Defective 63H input circuit)?	Replacement of PCB	
E41		Stays OFF	Keeps flashing	1 time flash	Keeps flashing	2 times flash or 6 times flash		Inverter PCB or radiator fin	• Power transistor overheat (Model 71VN,100VN,125VN,140VN,200VS,250VS)	Replacement of PCB or Repair	98
E42	Keeps flashing	Stays OFF	Keeps flashing	1 time flash	Keeps flashing	1 time flash or 5 times flash		Outdoor control PCB compressor	• Current cut (Anomalous compressor over-current)	Replacement of PCB	99 • 100
								Installation or operating condition	• Service valve closing operation	Repair	
E45		Stays OFF	Keeps flashing	1 time flash	Keeps flashing	Keeps flashing		Outdoor control PCB	• Anomalous outdoor control PCB communication	Service valve opening check	101
								Inverter PCB	• Anomalous inverter PCB communication	Replacement of PCB	
E47		Stays OFF	Keeps flashing	1 time flash	Keeps flashing	7 times flash		Inverter PCB activefilter	• Defective outdoor inverter PCB (Model FDC 71) Defective active filter of control.	Replacement	103
E48		Stays OFF	Keeps flashing	1 time flash	Keeps flashing			Outdoor fan motor	• Anomalous outdoor fan motor	Replacement, repair	105
								Outdoor control PCB	* Defective outdoor control PCB (Defective motor input circuit)?	Replacement of PCB	
E49		Stays OFF	Keeps flashing	1 time flash	Keeps flashing		Keeps flashing	Installation or operating condition	• Low pressure error • Service valve closing operation	Repair	106,107
								Low pressure sensor	• Anomalous low pressure, broken wire of low pressure sensor or poor connector connection	Replacement, repair of sensor	
								Outdoor control PCB	* Defective outdoor control PCB (Defective sensor input circuit)?	Replacement of control PCB	
E51		Stays OFF	Keeps flashing	1 time flash	Keeps flashing	2 times flash or 6 times flash		Inverter PCB	• Anomalous inverter PCB	Replacement of PCB	109
E53		Stays OFF	Keeps flashing	1 time flash	Keeps flashing			Suction pipe temperature thermistor	• Defective suction pipe temperature thermistor, broken wire or poor connector connection	Replacement, repair of temperature thermistor	110
								Outdoor control PCB	* Defective outdoor PCB (Defective thermistor input circuit)?	Replacement of control PCB	
E54		Stays OFF	Keeps flashing	1 time flash	Keeps flashing		Keeps flashing	Low pressure sensor	• Defective low pressure sensor	Replacement of sensor	111
								Outdoor control PCB	• Defective outdoor control PCB (Defective sensor input circuit)?	Replacement of control PCB	
E55		Stays OFF	Keeps flashing	1 time flash	Keeps flashing			Compressor underneath temperature thermistor	• Defective compressor underneath temperature thermistor (Models 200, 250 only)	Replacement of temperature thermistor	112
								Outdoor control PCB	• Defective outdoor control PCB (Defective thermistor input circuit)? (Models 200, 250 only)	Replacement of control PCB	
E57		Stays OFF	Keeps flashing	1 time flash	Keeps flashing			Operation status	• Shortage in refrigerant quantity	Repair	114
								Installation status	• Service valve closing operation	Service valve opening check	
E59		Stays OFF	Keeps flashing	5 times flash	Keeps flashing	Stays OFF or 4 times flash		Compressor inverter PCB	• Anomalous compressor startup	Replacement	117
E60		Stays OFF	Keeps flashing	1 time flash	Keeps flashing			Compressor	• Anomalous compressor rotor position detection (Models 200, 250 only)	Replacement	118

Note (1) * mark in the Description of trouble means that, in ordinary diagnosis, it cannot identify the cause definitely, and, if the trouble is repaired by replacing the part, it is judged consequently that the replaced part was defective.

- (2) This LED is installed on models FDC200, 250VS
- (3) This LED is installed on models FDC71~140VN, FDC100~140VS
- (4) This LED is installed on models FDC200, 250VS

(iii) Optional controller in-use

Error code	Indoor unit control PCB		Outdoor unit control PCB		Description of trouble	Repair method
	Red LED	Green LED	Red LED	Green LED		
E75	Keeps flashing	Stays OFF	Keeps flashing	Stays OFF	Keeps flashing	• Communication error (Defective communication circuit on the main unit of SC-SL2N-E or SC-SL3N-E) etc.

(iv) Display sequence of error codes or inspection indicator lamps



■ Occurrence of one kind of error

Displays are shown respectively according to errors.

■ Occurrence of plural kinds of error

Section	Category of display
Error code on remote controller	<ul style="list-style-type: none"> • Displays the error of higher priority (When plural errors are persisting) <p style="text-align: center;"><i>E 1 > E 5 > > E 10 > E 32 > > E 60</i></p>
Red LED on indoor control PCB	
Red LED on outdoor control PCB	
	<ul style="list-style-type: none"> • Displays the present errors. (When a new error has occurred after the former error was reset.)

■ Error detecting timing

Section	Error description	Error code	Error detecting timing
Indoor	Drain trouble (Float switch activated)	<i>E 9</i>	Whenever float switch is activated after 30 second had past since power ON.
	Communication error at initial operation	“  WAIT  ”	No communication between indoor and outdoor units is established at initial operation.
	Remote controller communication circuit error	<i>E 1</i>	Communication between indoor unit and remote controller is interrupted for mote than 2 minutes continuously after initial communication was established.
	Communication error during operation	<i>E 5</i>	Communication between indoor and outdoor units is interrupted for mote than 2 minutes continuously after initial communication was established.
	Excessive number of connected indoor units by controlling with one remote controller	<i>E 10</i>	Whenever excessively connected indoor units is detected after power ON.
	Return air temperature thermistor anomaly	<i>E 7</i>	-50°C or lower is detected for 5 seconds continuously within 60 minutes after initial detection of this anomalous temperature.
	Indoor heat exchanger temperature thermistor anomaly	<i>E 6</i>	-50°C or lower is detected for 5 seconds continuously within 60 minutes after initial detection of this anomalous temperature. Or 70°C or higher is detected for 5 seconds continuously.
Outdoor	Outdoor air temperature thermistor anomaly	<i>E 38</i>	-45 (-55)°C or lower is detected for 5 seconds continuously 3 times within 40 minutes after initial detection of this anomalous temperature. Or -45 (-55)°C or higher is detected for 5 seconds continuously within 20 seconds after compressor ON.
	Outdoor heat exchanger temperature thermistor anomaly	<i>E 37</i>	-50 (-55)°C or lower is detected for 5 seconds continuously 3 times within 40 minutes after initial detection of this anomalous temperature. Or -50 (-55)°C or lower is detected for 5 seconds continuously within 20 seconds after compressor ON.
	Discharge pipe temperature thermistor anomaly	<i>E 39</i>	-10 (-25)°C or lower is detected for 5 seconds continuously 3 times within 40 minutes after initial detection of this anomalous temperature.
	Suction pipe temperature thermistor anomaly	<i>E 53</i>	-50°C or lower is detected for 5 seconds continuously 3 times within 40 minutes after initial detection of this anomalous temperature.
	Low pressure sensor anomaly	<i>E 54</i>	0V or lower or 3.49V or higher is detected for 5 seconds continuously 3 times within 40 minutes after initial detection of this anomalous pressure.
	Underneath temperature thermistor anomaly	<i>E 55</i>	-50°C or lower is detected for 5 seconds continuously 3 times within 40 minutes after initial detection of this anomalous temperature.

Note (1) Value in () are for the models SRC40~60

■ **Error log and reset**

Error indicator	Memorized error log	Reset
Remote controller display	• Higher priority error is memorized.	• Stop the unit by pressing the ON/OFF switch of remote controller. • If the unit has recovered from anomaly, it can be operated.
Red LED on indoor control PCB	• Not memorized.	
Red LED on outdoor control PCB	• Memorizes a mode of higher priority.	

■ **Resetting the error log**

- Resetting the memorized error log in the remote controller
Holding down “CHECK” button, press “TIMER” button to reset the error log memorized in the remote controller.
- Resetting the memorized error log
The remote controller transmits error log erase command to the indoor unit when “VENTI” button is pressed while holding down “CHECK” button.
Receiving the command, the indoor unit erase the log and answer the status of no error.

(2) **Troubleshooting procedure**

When any trouble has occurred, inspect as follows. Details of respective inspection method will be described on later pages.

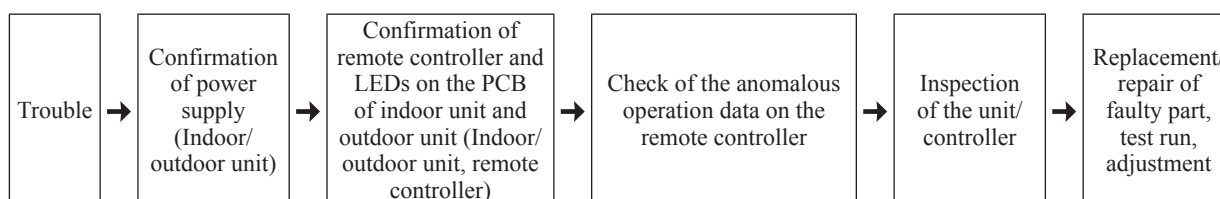

(3) **Troubleshooting at the indoor unit**

With the troubleshooting, find out any defective part by checking the voltage (AC, DC), resistance, etc. at respective connectors at around the indoor PCB, according to the inspection display or operation status of unit (the compressor does not run, fan does not run, the 4-way valve does not switch, etc.), and replace or repair in the unit of following part.

(a) **Replacement part related to indoor PCB's**

Control PCB, power supply PCB, temperature thermistor (return air, indoor heat exchanger), remote controller switch, limit switch, transformer and fuse

Note (1) With regard to parts of high voltage circuits and refrigeration cycle, judge it according to ordinary inspection methods.

(b) **Instruction of how to replace indoor control PCB**

SAFETY PRECAUTIONS

- Read the "SAFETY PRECAUTIONS" carefully first of all and then strictly follow it during the replacement in order to protect yourself.
- The precautionary items mentioned below are distinguished into two levels, WARNING and CAUTION. Both mentions the important items to protect your health and safety so strictly follow them by any means.

⚠ WARNING	Wrong installation would cause serious consequences such as injuries or death.
⚠ CAUTION	Wrong installation might cause serious consequences depending on circumstances.

- After completing the replacement, do commissioning to confirm there are no anomaly.

⚠ WARNING

- Replacement should be performed by the specialist.
If you replace the PCB by yourself, it may lead to serious trouble such as electric shock or fire.
- Replace the PCB correctly according to these instructions.
Improper replacement may cause electric shock or fire.
- Shut off the power before electrical wiring work.
Replacement during the applying the current would cause the electric shock, unit failure or improper running.
It would cause the damage of connected equipment such as fan motor, etc.
- Fasten the wiring to the terminal securely, and hold the cable securely so as not to apply unexpected stress on the terminal.
Loose connections or hold could result in abnormal heat generation or fire.
- Check the connection of wiring to PCB correctly before turning on the power, after replacement.
Defectiveness of replacement may cause electric shock or fire.

⚠ CAUTION

- In connecting connector onto the PCB, connect not to deform the PCB. It may cause breakage or malfunction.
- Insert connector securely, and hook stopper. It may cause fire or improper running.
- Bundle the cables together so as not to be pinched or be tensioned. It may cause malfunction or electric shock for disconnection or deformation.

◆ **Model: FDT, FDTC series**

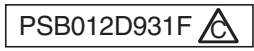

• Control PCB

Replace and set up the PCB according to this instruction.

① Set to an appropriate address and function using switch on PCB.

Select the same setting with the removed PCB.

item	switch	Content of control			
Address	SW2	Plural indoor units control by 1 remote controller			
Master /Slave setting		Master	Slave1	Slave2	Slave3
	SW5-1	—	—	○	○
	SW5-2	—	○	—	○
Test run	SW7-1	—	Normal		
		○	Operation check/drain motor test run		

○:ON —:OFF

② Set to an appropriate capacity using the model selector switch(SW6).

Select the same capacity with the PCB removed from the unit.

SW6	-1	-2	-3	-4
40V	○	○	—	—
50V	○	—	○	—
60V	○	○	○	—
71V	○	—	—	○

SW6	-1	-2	-3	-4
100V	○	○	—	○
125V	—	—	○	○
140V	○	—	○	○

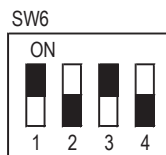

Example setting for 50V

③ Replace the PCB

1. Fix the PCB so as not to pitch the cords.
2. Connect connectors to the PCB. Connect a cable connector with the PCB connector of the same color.
3. Do not pass CPU surrounding about wirings.

④ Control PCB

Parts mounting are different by the kind of PCB.

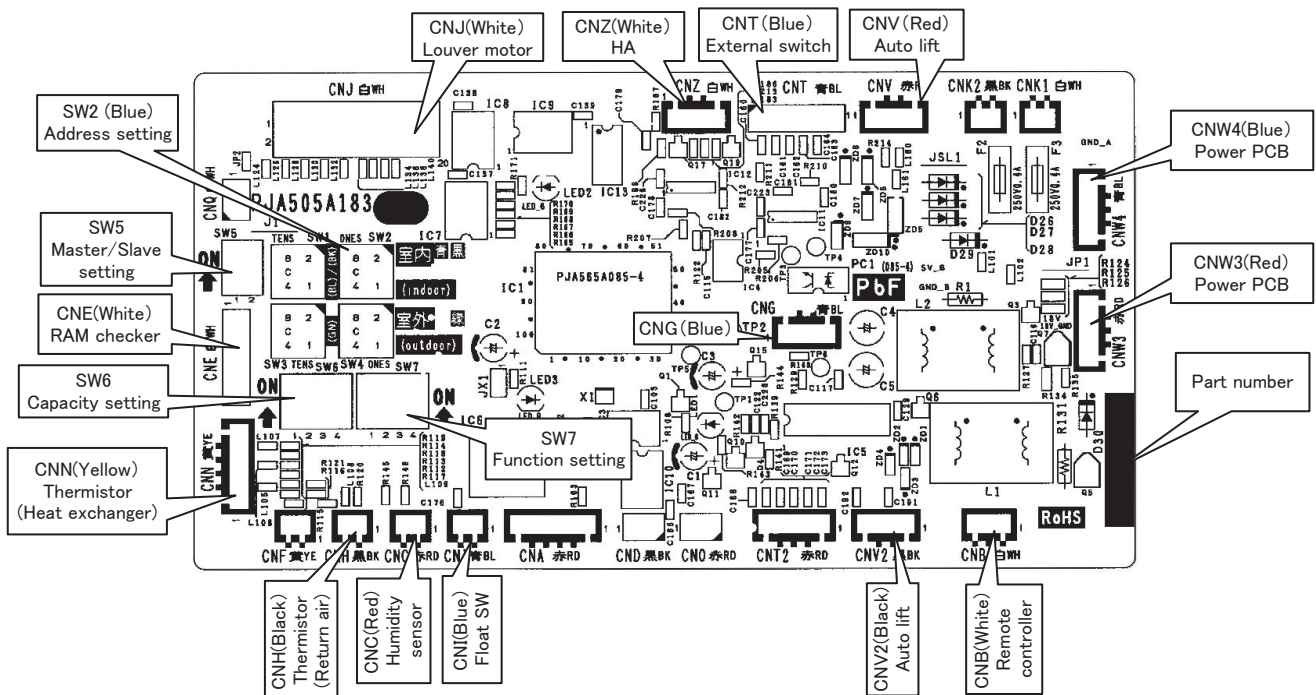

• Power PCB

PSB012D953A

This PCB is a general PCB. Replace the PCB according to this instruction.

① Replace the PCB (refer to right dwg.)

1. Unscrew terminal of the wiring(yellow/green) soldered to PCB from the box.
 2. Cut the band that binds the wiring (red and blue) from connector CNW1 and CNW2, and the wiring (yellow/green) from PCB (T2/T3) . (Note 1)
(However, do not cut the band that binds only the red and blue wirings.)
 3. Replace the PCB only after all the wirings connected to the connector are removed.
 4. Fix the board such that it will not pinch any of the wires.
 5. Reconnect the wirings to the PCB. Wiring connector color should match with the color of connector of the PCB. (Note 2)
 6. Let the wiring (red and blue) pass beneath the (yellow/green) wiring and bind together with band.
 7. Screw back the terminal of wiring (yellow/green) from PCB(T1, T2/T3), that was removed in 1.
In that case, do not place the crimping part of the wiring under the PCB.
- (Note 1): It might not be applicable on some models.
(Note 2): After replacing PCB, connection between capacitor assy and connector CNP is **no longer needed.**

② Power PCB

Parts mounting are different by the kind of PCB.

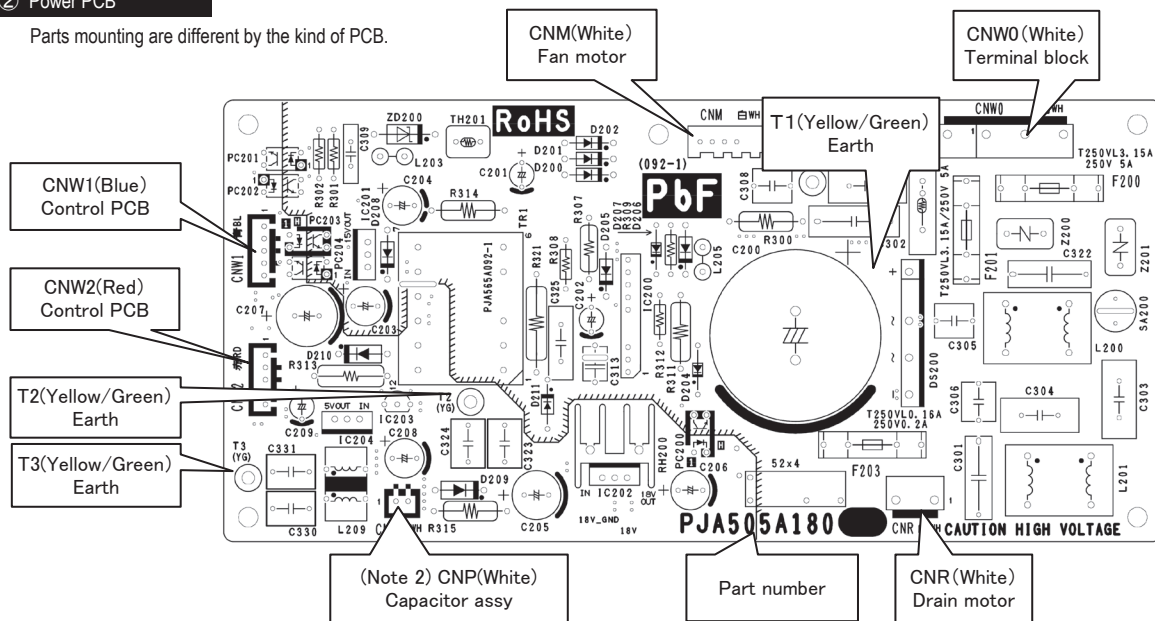

for FDT

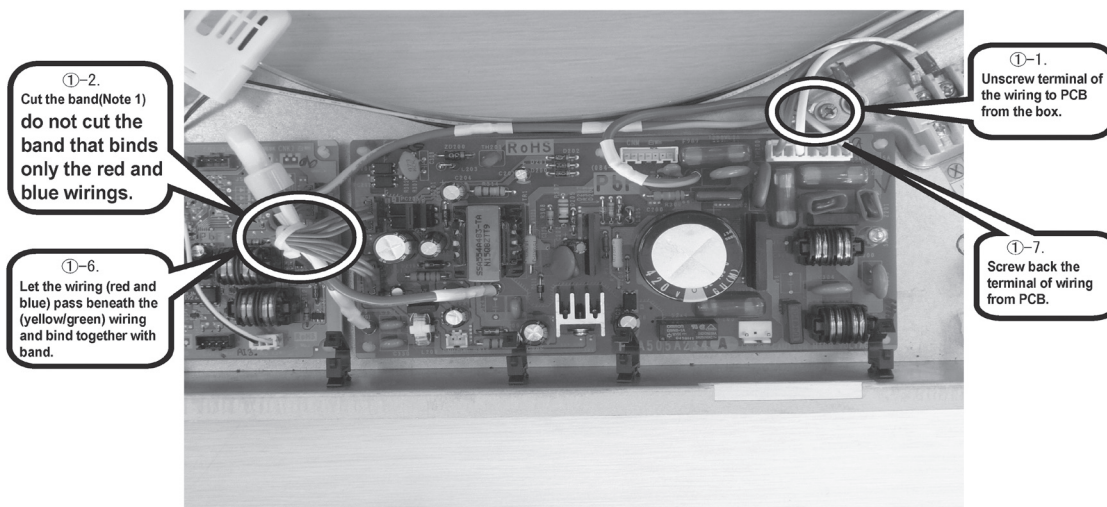

for F D T C

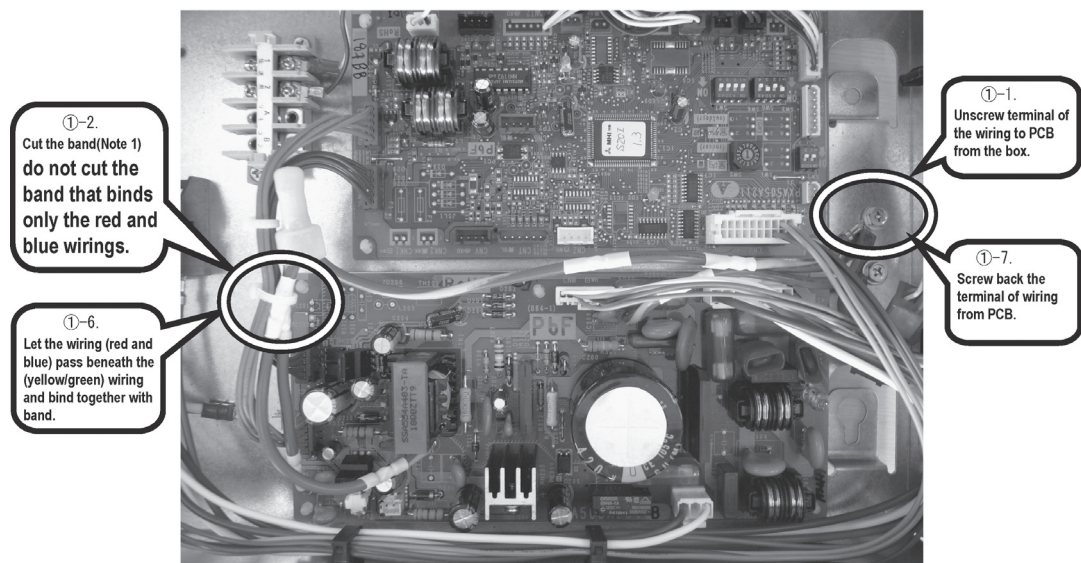

①-2.
Cut the band(Note 1)
do not cut the
band that binds
only the red and
blue wirings.

①-6.
Let the wiring (red and
blue) pass beneath the
(yellow/green) wiring
and bind together with
band.

①-1.
Unscrew terminal of
the wiring to PCB
from the box.

①-7.
Screw back the
terminal of wiring
from PCB.

◆ Model: FDUM, FDU, FDEN series

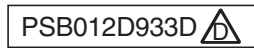

① Set to an appropriate address and function using switch on PCB.

1. There is a unit having plural applicable PCB depending on a model.
2. Set the function setting corresponding the spare PCB and the applicable model.

item	switch	Content of control			
Address	SW2	Plural indoor units control by 1 remote controller			
Master /Slave setting	SW5-1	Master	Slave1	Slave2	Slave3
	SW5-2	—	—	—	—
Test run	SW7-1	—	Normal		
		○	Operation check/drain motor test run		

○ : ON — : OFF

② Set to an appropriate capacity using the model selector switch(SW6).

Select the same capacity with the PCB removed from the unit.

SW6	-1	-2	-3	-4
40V	○	○	—	—
50V	○	—	○	—
60V	○	○	○	—
71V	○	—	—	○

SW6	-1	-2	-3	-4
100V	○	○	—	○
125V	—	—	○	○
140V	○	—	○	○

SW6	-1	-2	-3	-4
200V	—	○	○	○
250V	○	○	○	○

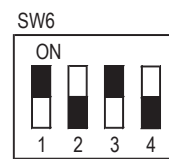

Example setting for 50V

③ Replace the PCB

1. Fix the PCB so as not to pitch the cords.
2. Connect connectors to the PCB. Connect a cable connector with the PCB connector of the same color.
3. Do not pass CPU surrounding about wirings.

④ Control PCB

Parts mounting are different by the kind of PCB.

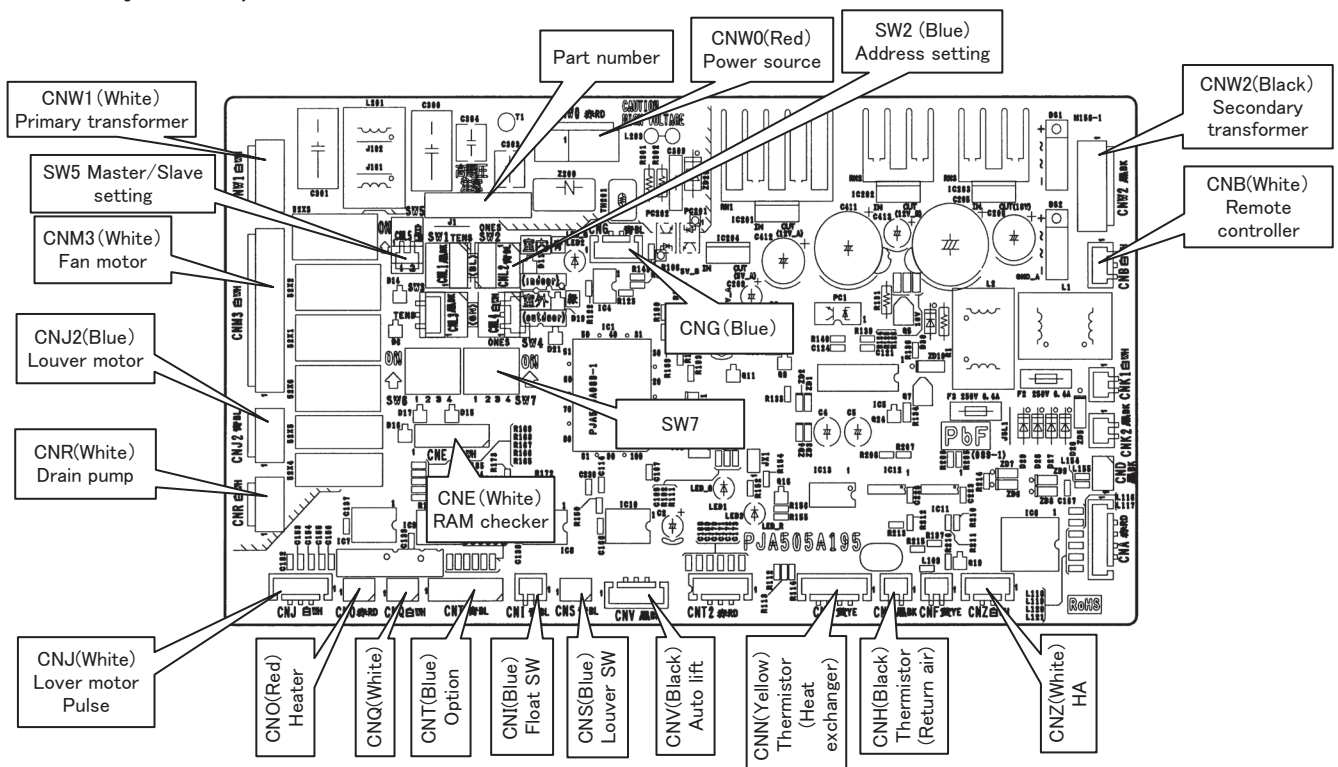

●DIP switch setting list

Switches	Description		Default setting		Remarks
SW2	Address No. setting at plural indoor units control by 1 R/C		0		0-F
SW5-1	Master/Slave setting	Master*/Slave	OFF		See table 2
SW5-2			OFF		
SW6-1	Model selection		As per model		See table 1
SW6-2					
SW6-3					
SW6-4					
SW7-1	Test run, Drain motor	Normal*/Test run	OFF	Normal	
SW7-2	Reserved		OFF		keep OFF
SW7-3	Powerful mode	Valid*/Invalid(FDU only)	ON	Valid	
SW7-4	Reserved		OFF		keep OFF
JSL1	Superlink terminal spare	Normal*/switch to spare	With		

* Default setting

Table 1: Indoor unit model selection with SW6-1-SW6-4

	0: OFF 1:ON								
	40V	50V	60V	71V	100V	125V	140V	200V	250V
SW6-1	1	1	1	1	1	0	1	0	1
SW6-2	1	0	1	0	1	0	0	1	1
SW6-3	0	1	1	0	0	1	1	1	1
SW6-4	0	0	0	1	1	1	1	1	1

Table 2: Indoor unit Master/Slave setting with SW5-1,SW5-2

	0: OFF 1:ON	
	SW5-1	SW5-2
Master	0	0
Slave1	0	1
Slave2	1	0
Slave3	1	1

(4) Troubleshooting at the outdoor unit

When troubleshooting the outdoor unit, firstly assess the overview of malfunction and try to presume the cause and the faulty part by checking the error code displayed on the remote controller and flashing pattern of indicator lamps (Red LED and Green LED), and then proceed further inspection and remedy it.

Self-diagnosis system by microcomputer on indoor and outdoor PCB can assist to find the cause of malfunction smoothly by making a diagnosis of not only the anomaly of microcomputer, but also the anomaly in power supply system, installation space, overload resulting from improper charging amount of refrigerant and etc.

Unless the power is reset, the error log is saved in memory and the inspection indicator lamps on outdoor PCB keep flashing after automatical recovering from malfunction.

After automatical recovering from malfunction, if any another error mode which has a higher priority than the previous error saved in memory occurs, it is overwritten in memory and is displayed.

[Reset of power supply]

Be sure to avoid electrical shock, when replacing or checking the outdoor control PCB, because some voltage is still retained in the electrolytic capacitor on the PCB even after shutting down the power supply to the outdoor unit.

Be sure to start repairing work, after confirming that the Red LED (or Green LED for 71-250type) on the PCB has been extinguished for more than 10 seconds after more than 3 minutes had been passed since power shut down, and reconfirming that voltage has been discharged sufficiently by measuring the voltage (DC) between both terminals of electrolytic capacitor (C58) (Measurement of voltage may be disturbed by the moisture-proof coating. In such case, remove the coating and measure it by taking care of avoiding electrical shock)

(a) Module of part to be replaced for outdoor unit controller

Outdoor control PCB, Inverter PCB, Temperature thermistor (of outdoor heat exchanger, discharge pipe, outdoor air, IPM and suction pipe), Fuses (for power supply and control PCB), Noise filter, Capacitor, Reactor and Transformer

(b) Replacement procedure of outdoor control PCB

Precautions for Safety	
<ul style="list-style-type: none"> • Since the following precaution is the important contents for safety, be sure to observe them. WARNING and CAUTION are described as follows: 	
<div style="border: 1px solid black; padding: 2px; display: inline-block;"> WARNING</div>	Indicates an imminently hazardous situation which will result in death or serious injury if proper safety procedures and instructions are not adhered to.
<div style="border: 1px solid black; padding: 2px; display: inline-block;"> CAUTION</div>	Indicates a potentially hazardous situation which may result in minor or moderate injury if proper safety procedures and instructions are not adhered to.
<div style="border: 1px solid black; padding: 2px; display: inline-block;"> WARNING</div>	
<ul style="list-style-type: none"> • Securely replace the PCB according to this procedure. If the PCB is incorrectly replaced, it will cause an electric shock or fire. • Be sure to check that the power source for the outdoor unit is turned OFF before replacing the PCB. The PCB replacement under current-carrying will cause an electric shock or fire. • After finishing the PCB replacement, check that wiring is correctly connected with the PCB before power distribution. If the PCB is incorrectly replaced, it will cause an electric shock or fire. 	
<div style="border: 1px solid black; padding: 2px; display: inline-block;"> CAUTION</div>	
<ul style="list-style-type: none"> • Band the wiring so as not to tense because it will cause an electric shock. 	

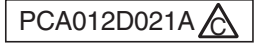

1) Model FDC71VN

- a) Replace the PCB **after elapsing 3 minutes from power OFF.**
(Be sure to measure voltage (DC) between T26 and T27 on inverter PCB, and check that the voltage is discharged sufficiently(10V or less).(Refer to Fig.1))
- b) Disconnect the connectors from the control PCB.
- c) Match the switches setting (SW4) with the former PCB.
- d) Connect the connectors to the control PCB.(Confirm the **connectors are not half inserted.**)

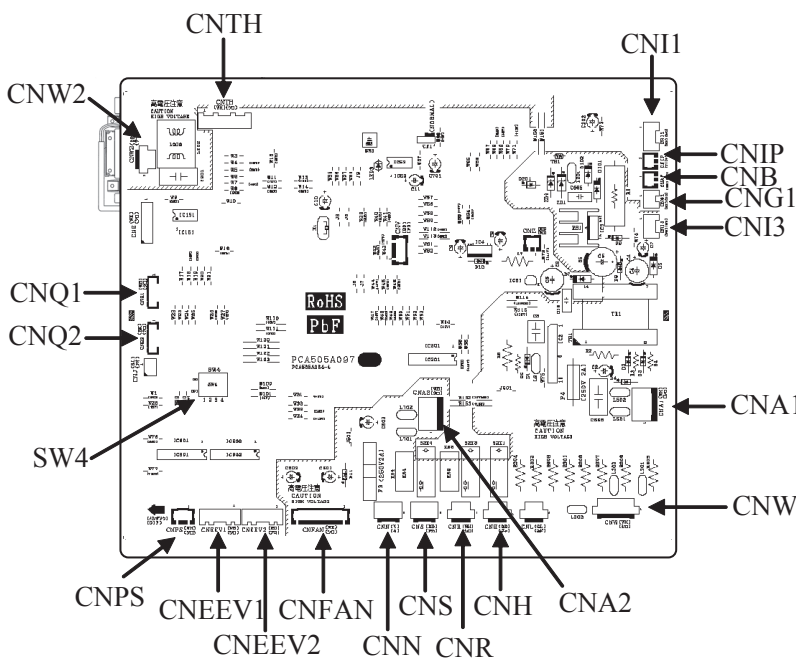

Parts Arrangement View

connectors are not half inserted

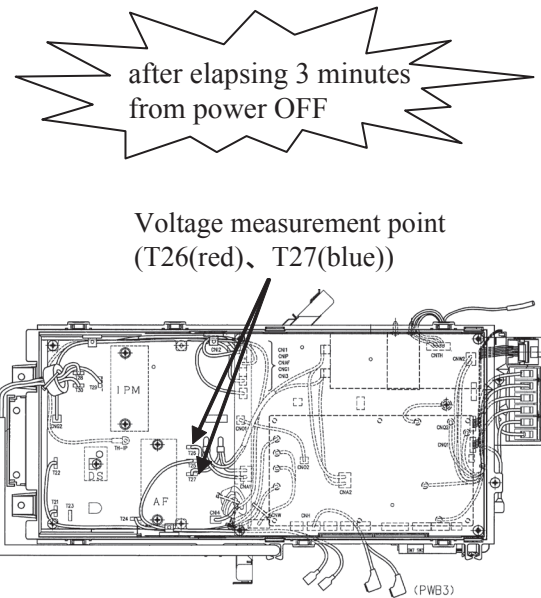
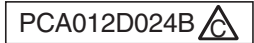
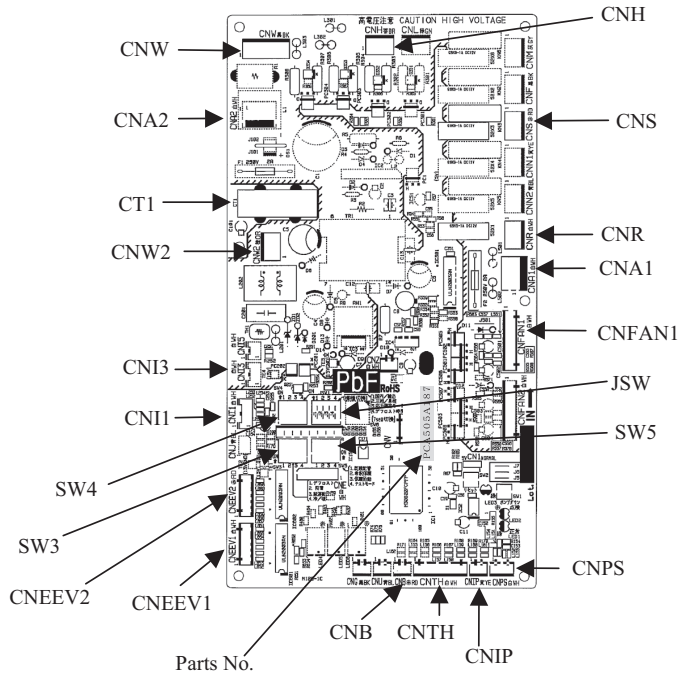

Fig.1 Position of terminal



2) Model FDC100VN, 125VN, 140VN

- a) Replace the PCB **after elapsing 3 minutes from power OFF.**
(Be sure to measure voltage (DC) on both capacitor terminals located in controller back, and check that the voltage is discharged sufficiently. (Refer to Fig.1))
- b) Disconnect the connectors from the control PCB.
- c) Disconnect the white wiring passing through CT1 on the PCB before replacing the PCB.
- d) Match the setting switches (SW3-5,JSW) with the former PCB.
- e) Tighten up a screw after passing white wiring through CT1 of the changed.
- f) Connect the connectors to the control PCB.(Confirm the **connectors are not half inserted.**)



Parts No.
 Parts arrangement view
 connectors are not half inserted

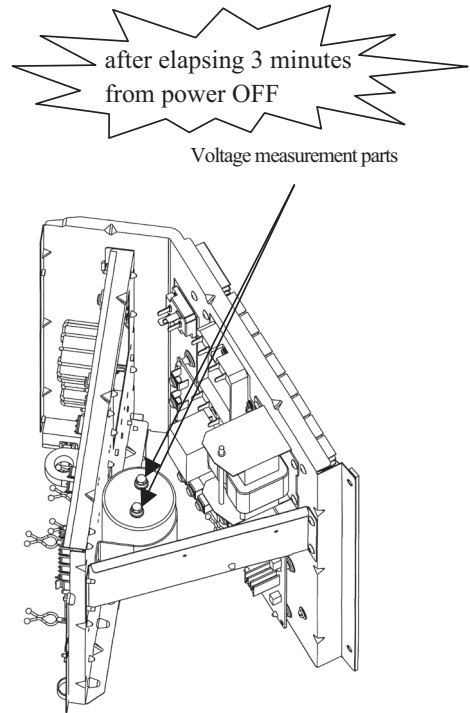
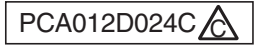

Fig.1 Position of capacitor



3) Model FDC100VS, 125VS, 140VS

- a) Replace the PCB **after elapsing 3 minutes from power OFF.**
(Be sure to measure voltage (DC) on both capacitor terminals located in controller back, and check that the voltage is discharged sufficiently. (Refer to Fig.1))
- b) Disconnect the connectors from the control PCB.
- c) Disconnect the white wiring passing through CT1 on the PCB before replacing the PCB.
- d) Match the setting switches (SW3-5,JSW) with the former PCB.
- e) Tighten up a screw after passing white wiring through CT1 of the changed.
- f) Connect the connectors to the control PCB. (Confirm the **connectors are not half inserted.**)

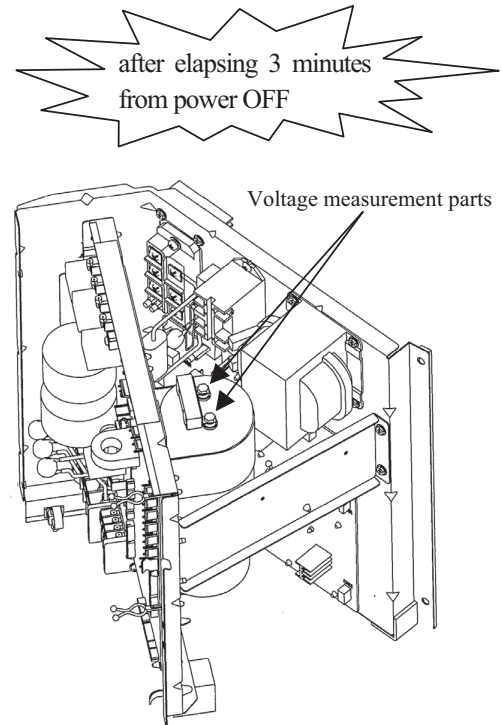
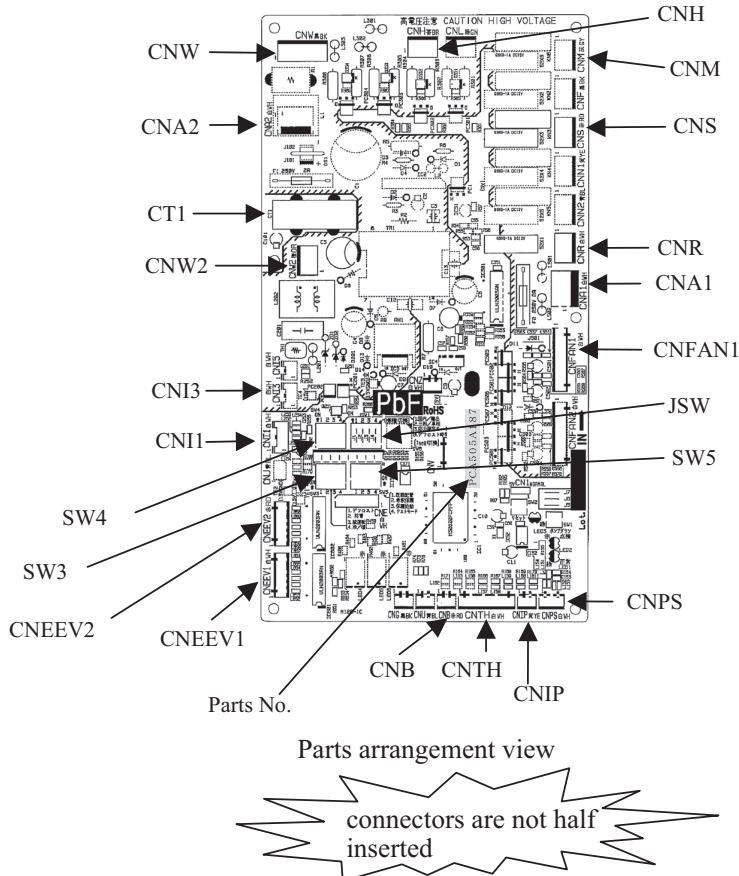
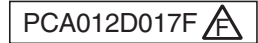
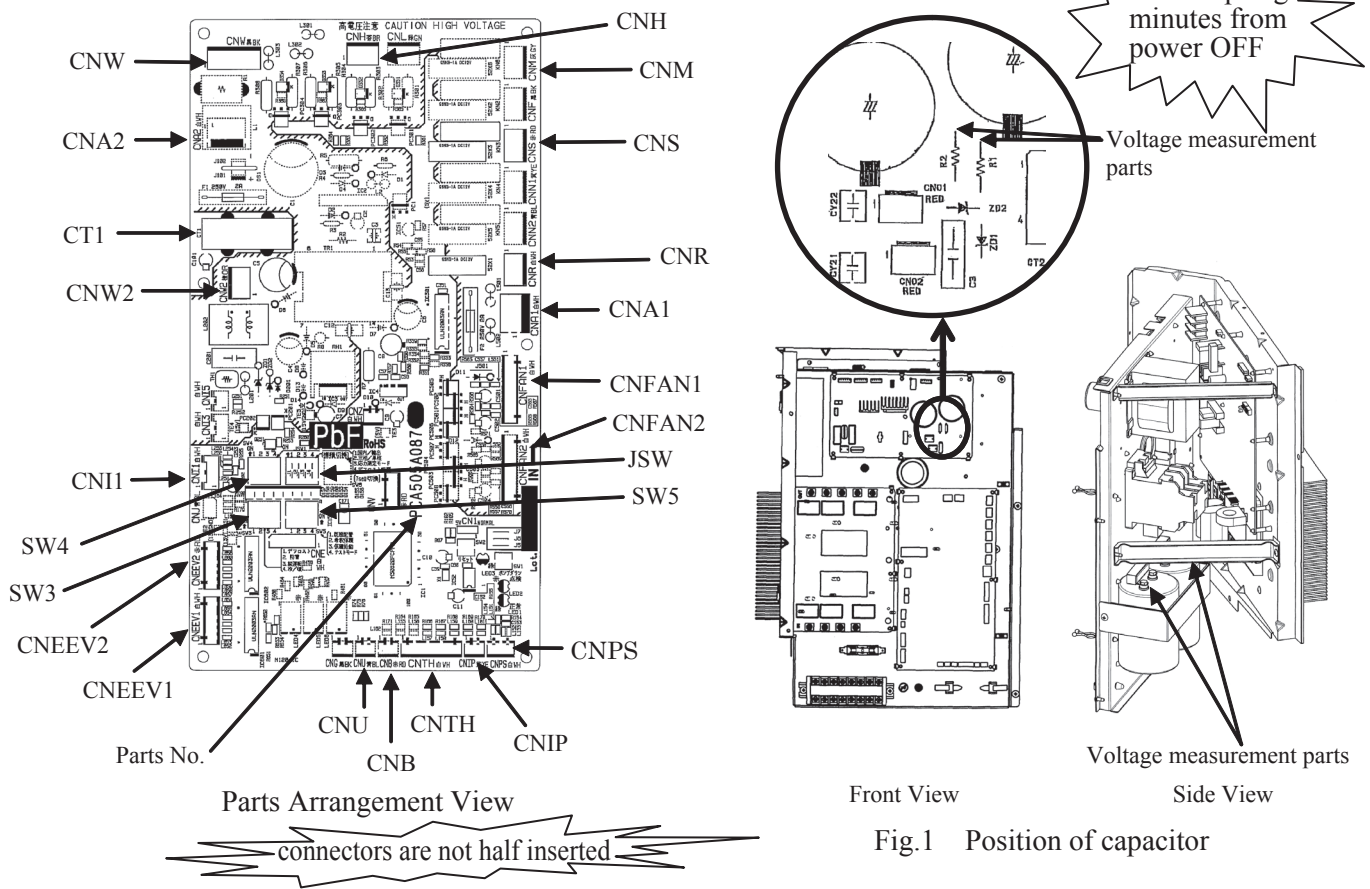

Fig.1 Position of capacitor

4) Model FDC200,250VS



- a) Replace the PCB **after elapsing 3 minutes from power OFF.**
(Be sure to measure the voltage (DC) of two places (1.Resistor on PCB at the front of controller
 2.Both capacitor terminals located in back of controller), and **check that the voltage is discharged sufficiently.** (Refer to Fig.1))
- b) Disconnect the connectors from the control PCB.
- c) Disconnect the blue wiring passing through CT1 on the substrate before replacing the PCB.
- d) Match the setting switches (SW3-5,JSW) with the former PCB.
- e) Tighten up a screw after passing blue wiring through CT1 of the changed.
- f) Connect the connectors to the control PCB. (Confirm the **connectors are not half inserted**)



Front View
Side View
Fig.1 Position of capacitor

(c) Outdoor inverter PCB replacement procedure

Precautions for Safety

- Since the following precaution is the important contents for safety, be sure to observe them.
WARNING and CAUTION are described as follows:

WARNING Indicates an imminently hazardous situation which will result in death or serious injury if proper safety procedures and instructions are not adhered to.

CAUTION Indicates a potentially hazardous situation which may result in minor or moderate injury if proper safety procedures and instructions are not adhered to.

WARNING

- Securely replace the PCB according to this procedure.
If the PCB is incorrectly replaced, it will cause an electric shock or fire.
- Be sure to check that the power source for the outdoor unit is turned OFF before replacing the PCB. The PCB replacement under current-carrying will cause an electric shock or fire.
- After finishing the PCB replacement, check that wiring is correctly connected with the PCB before power distribution. If the PCB is incorrectly replaced, it will cause an electric shock or fire.

CAUTION

- Band the wiring so as not to tense because it will cause an electric shock.

Replace the inverter PCB according to the following procedure.

1) Model FDC71VN

PCA012D022D

- a) Replace the PCB **after elapsing 3 minutes from power OFF.**
(Be sure to measure voltage (DC) between T26 and T27 on inverter PCB, and check that the voltage is discharged sufficiently (10V or less). (Refer to Fig.1))
- b) Take off the connection of inverter PCB terminal and connector, and remove the screw of power transistor (IC10), active filter (IC2), and diode stack (DS1) then remove the PCB. Wipe off the silicon grease neatly on the controller's radiation heat fins. (Refer to Fig.1 and 2)
- c) Refer to table1 for the setting of switch (JSW10, 11) of new PCB.
- d) Before installing the power transistor (IC10), active filter (IC2), and diode stack (DS1) on the new PCB, apply silicon grease equally to the their surface. (Make full use of the silicon grease.) **They may be damaged unless they apply it.**
- e) Tighten the screw of power transistor (IC10), active filter (IC2), and diode stack (DS1) on inverter PCB and connect terminal and connector. Confirm the connection and there is not the half insertion. **Tighten properly power transistor, (IC10) active filter (IC2), and diode stack (DS1) with a screw and make sure there is no slack. They can be damage if not properly tighten.** (Recommended tightening torque: power transistor (IC10)1.2±0.1 and active filter (IC2)0.98±0.1, diode stack(DS1) 0.5±0.1 Unit N·m

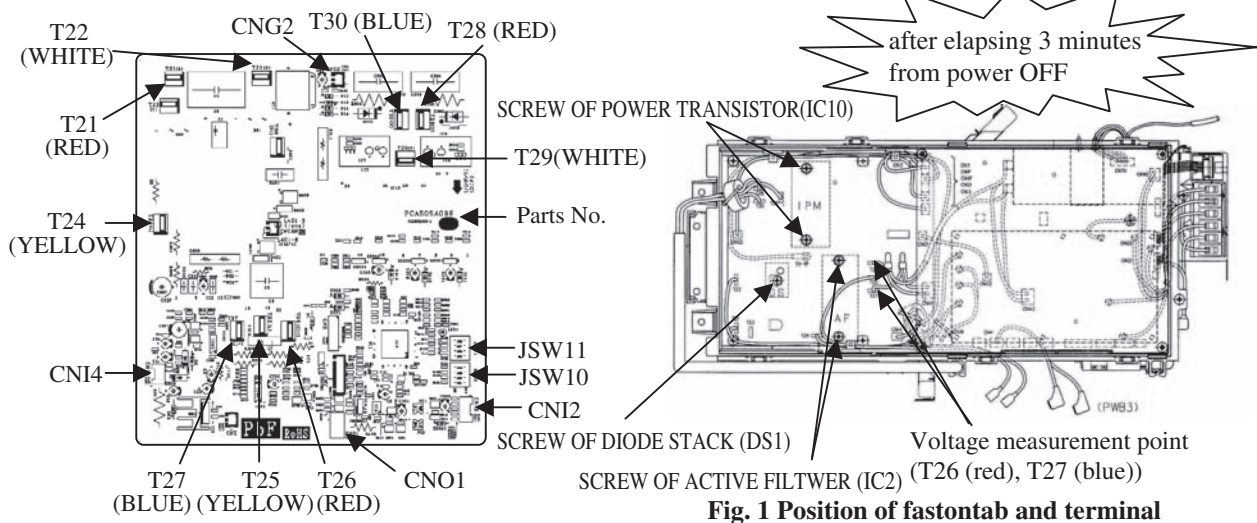

Fig. 1 Position of fastontab and terminal

Table. 1 Switch setting

JSW10	-1	OFF	JSW11	-1	ON
	-2	OFF		-2	ON
	-3	OFF		-3	OFF
	-4	OFF		-4	OFF

Connectors are not half inserted

2) Model FDC100VN, 125VN, 140VN

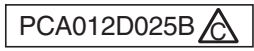

- a) Replace the PCB **after elapsing 3 minutes from power OFF.**
(Be sure to measure voltage (DC) on both capacitor terminals located in controller back, and check that the voltage is discharged sufficiently. (Refer to Fig.1))
- b) Take off the connection of inverter PCB terminal block connector and remove the screw of power transistor then remove the PCB. Wipe off the silicon grease neatly on the controller's radiation heat fins.
- c) Refer to table1 for the setting of switch (JSW10,11) of new PCB.
- d) Before installing the power transistor on the new PCB,Apply uniformly a bundled of silicon grease first on the surface of power transistor.Make sure it is applied to prevent damage on power transistor.
- e) Tighten the screw of power transistor on inverter PCB and connect the terminal block.Confirm the connection and don't use soldering in the connection.Tighten properly the power transistor with a screw and make sure there is no clearance gap.Power transistor can be damage if not properly tighten.(Recommended power transistor tightening torque:0.98~1.47N·m)

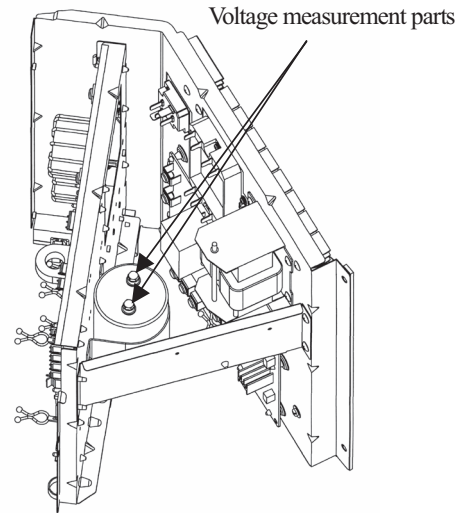
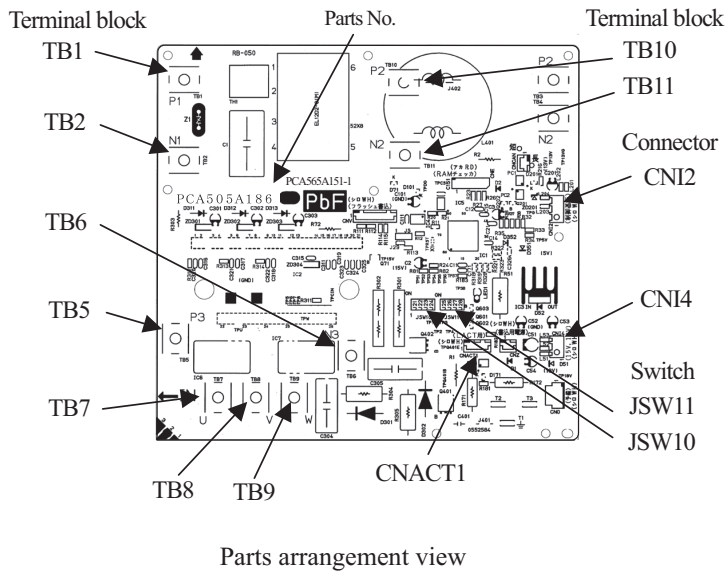
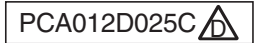

Fig.1 Position of capacitor

Table. 1 Switch setting

JSW 10	-1	OFF	JSW 11	-1	ON
	-2	OFF		-2	OFF
	-3	OFF		-3	OFF
	-4	OFF		-4	ON

3) Model FDC100VS, 125VS, 140VS



- a) Replace the PCB **after elapsing 3 minutes from power OFF.**
(Be sure to measure voltage (DC) on both capacitor terminals located in controller back, and check that the voltage is discharged sufficiently. (Refer to Fig.1))
- b) Take off the connection of inverter PCB terminal block connector and remove the screw of power transistor then remove the PCB. Wipe off the silicon grease neatly on the controller's radiation heat fins.
- c) Refer to table1 for the setting of switch (JSW10,11) of new PCB.
- d) Before installing the power transistor on the new PCB, Apply uniformly a bundled of silicon grease first on the surface of power transistor. Make sure it is applied to prevent damage on power transistor.
- e) Tighten the screw of power transistor on inverter PCB and connect the terminal block. Confirm the connection and don't use soldering in the connection. Tighten properly the power transistor with a screw and make sure there is no clearance gap. Power transistor can be damage if not properly tighten. (Recommended power transistor tightening torque: 0.98~1.47N·m)

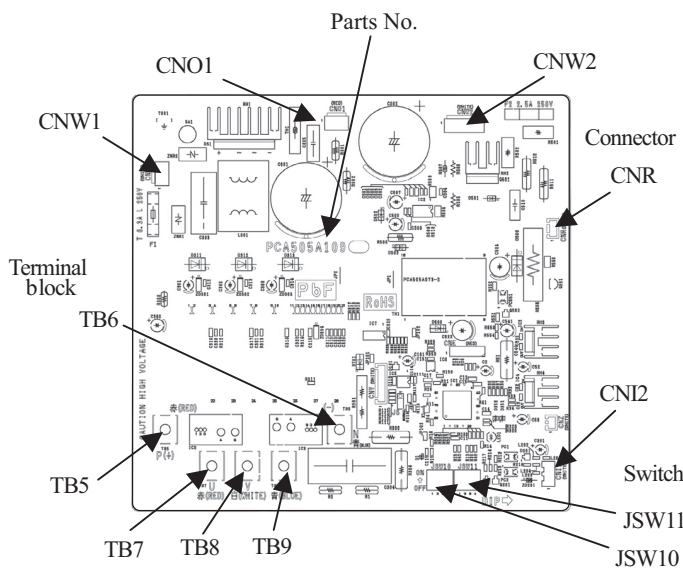

Parts arrangement view

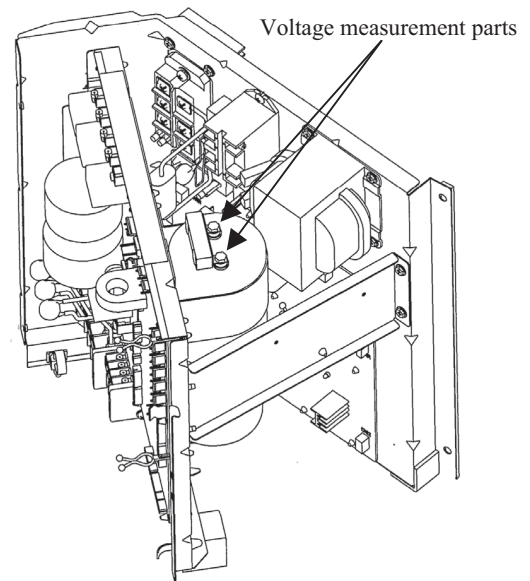



Fig.1 Position of capacitor

Table. 1 Switch setting

JSW10	-1	OFF	JSW11	-1	OFF
	-2	OFF		-2	ON
	-3	OFF		-3	OFF
	-4	OFF		-4	ON

4) Model FDC200VS, 250VS

PCB012D007C 

- a) Replace the inverter PCB after 10 minutes from power OFF. (Be sure to check that LED (LED1,2) of the inverter PCB put out the lights. It measures that the voltage (AC) between terminals (R,S,T) on the noise filter PCB (see Fig 1) is discharged sufficiently.)
- b) Remove the terminal on the terminal block (TB2) of the inverter PCB and the connector (CNR) of replace the PCB.
- c) Make set switch (SW1,2) as shown in Table 1.
- d) Connect the terminal of terminal block and the connector to the inverter PCB.
 ※Remove the short bar form the PCB before the replacement.
 Connect it with P2-P3 pins of PCB after the replacement.

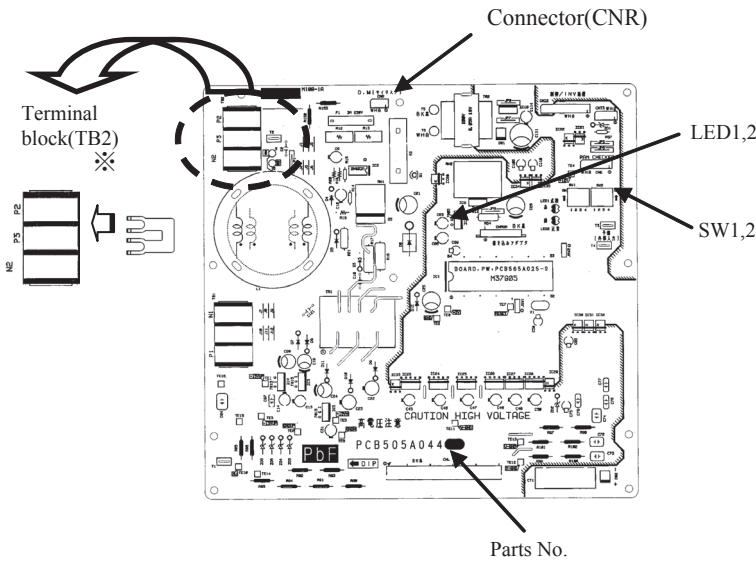

Parts Arrangement View
(the inverter PCB)

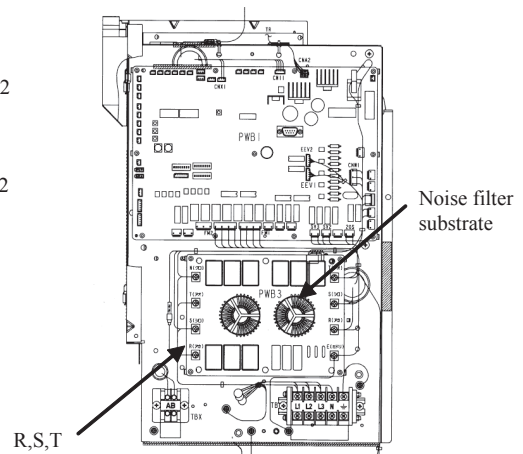

Fig. 1 The front of control

Table.1 Switch setting

In case of one substrate.

SW1-1	OFF
SW1-2	OFF
SW1-3	OFF
SW1-4	OFF
SW2-1	ON
SW2-2	OFF
SW2-3	OFF
SW2-4	OFF

● DIP switch setting list (Outdoor unit)

(1) Control PCB

Model FDC71VN

Switches	Description		Default setting		Remarks
SW3-1	Defrost condition	Normal*/Cold region	OFF	Normal	
SW3-2	Snow protection control	Normal*/Snow protection	OFF	Normal	
SW3-3	Model selection	Cooling only/Heat pump*	OFF	Heat pump	Keep OFF
SW3-4	Defrost prohibition time	ON: 37min*/OFF: 45min	ON	37min.	
SW4-1	Model selection	Domestic/Overseas*	ON	Overseas	Keep ON
SW4-2	Model selection	3-phase/Single phase*	ON	Single phase	Keep ON
SW4-3	Reserved		OFF		Keep OFF
SW4-4	Spare		OFF		Keep OFF
SW5-1	Model selection	Capacity	OFF		Keep OFF
SW5-2	Model selection	Capacity	OFF		Keep OFF
SW5-3	Test run SW	Normal*/Test run	OFF	Normal	
SW5-4	Test run mode	Cooling*/Heating	OFF	Cooling	
SW7-1	Spare		OFF		
SW7-2	Antifrost control	Valid*/Invalid	OFF	Valid	
SW7-3	Spare		OFF		Keep OFF
SW8-1	Reserved		OFF		Keep OFF
SW8-2	Spare		OFF		Keep OFF
SW8-3	Spare		OFF		Keep OFF
SW9	Pump down operation	Normal*/Pump down	OFF	Normal	

* Default setting

Models FDC100,125,140VN,100,125,140,200,250VS

Switches	Description		Default setting		Remarks
SW1	Pump down operation	Normal*/Pump down	OFF	Normal	
J5W1-1	Model selection		As per model		See table 1
J5W1-2					
J5W1-3					
J5W1-4					
SW3-1	Defrost condition	Normal*/Cold region	OFF	Normal	
SW3-2	Snow protection control	Normal*/Snow protection	OFF	Normal	
SW3-3	Test run SW	Normal*/Test run	OFF	Normal	
SW3-4	Test run mode	Cooling*/Heating	OFF	Cooling	
SW4-1	Model selection	Domestic/Overseas*	ON	Overseas	See table 1
SW4-2	Model selection	3-phase/Single phase	As per model		See table 1
SW4-3	Reserved		OFF		Keep OFF
SW4-4	Reserved		OFF		Keep OFF
SW5-1	Reserved		OFF		Keep OFF
SW5-2	Reserved		OFF		Keep OFF
SW5-3	Reserved		OFF		Keep OFF
SW5-4	Reserved		OFF		Keep OFF
J5	Antifrost control	Valid*/Invalid	With	Valid	
J6	Drain pan heater	Normal*/Equipped	With	Normal	
J7	Outdoor fan control when ducting	Normal*/Hi tap	With	Normal	

* Default setting

Table 1: Outdoor unit model selection with JSW1-1-JSW1-4 and SW4-1-SW4-2

0: OFF 1: ON

	100VN	100VS	125VN	125VS	140VN	140VS	200VS	250VS
J5W1-1	0	0	1	1	0	0	1	0
J5W1-2	0	0	0	0	1	1	1	0
J5W1-3	0	0	0	0	0	0	0	1
J5W1-4	0	0	0	0	0	0	0	0
SW4-1	1	1	1	1	1	1	1	1
SW4-2*	1	0	1	0	1	0	0	0

* 3-phase: OFF/Single phase: ON

(2) Inverter PCB

Switches	71VN	100, 125, 140VN	100, 125, 140VS
	Single phase models	Single phase models	3-phase models
J5W10-1	OFF	OFF	OFF
J5W10-2	OFF	OFF	OFF
J5W10-3	OFF	OFF	OFF
J5W10-4	OFF *	OFF *	OFF *
J5W11-1	ON	ON	OFF
J5W11-2	ON	OFF	ON
J5W11-3	OFF	OFF	OFF
J5W11-4	OFF	ON	ON

Switches	200,250VS
	3-phase models
SW1-1	OFF
SW1-2	OFF
SW1-3	OFF
SW1-4	OFF
SW2-1	ON
SW2-2	OFF
SW2-3	OFF
SW2-4	OFF

* When checking inverter PCB of FDC71~140 models with inverter checker, turn JSW10-4 ON.

(Regarding the checking method of inverter PCB with inverter checker, refer to page 54 for details)

*

(5) Check of anomalous operation data with the remote controller

Operation data can be checked with remote control unit operation.

- ① Press the **CHECK** button.
The display change “OPER DATA ▼”
- ② Press the **(SET)** button while “OPER DATA ▼” is displayed.
- ③ When only one indoor unit is connected to remote controller, “DATA LOADING” is displayed (blinking indication during data loading).
Next, operation data of the indoor unit will be displayed. Skip to step ⑦.
- ④ When plural indoor units is connected, the smallest address number of indoor unit among all connected indoor unit is displayed.

[Example]:

“SELECT I/U” (blinking 1 seconds) → “I/U000 ▲” blinking.

- ⑤ Select the indoor unit number you would like to have data displayed with the **▲ ▼** button.
- ⑥ Determine the indoor unit number with the **(SET)** button.
(The indoor unit number changes from blinking indication to continuous indication)
“I/U000” (The address of selected indoor unit is blinking for 2 seconds.)



“DATA LOADING” (A blinking indication appears while data loaded.)

Next, the operation data of the indoor unit is indicated.

- ⑦ Upon operation of the **▲ ▼** button, the current operation data is displayed in order from data number 01.

The items displayed are in the above table.

*Depending on models, the items that do not have corresponding data are not displayed.

- ⑧ To display the data of a different indoor unit, press the **AIR CON NO.** button, which allows you to go back to the indoor unit selection screen.
- ⑨ Pressing the **ON/OFF** button will stop displaying data.

Pressing the **(RESET)** button during remote control unit operation will undo your last operation and allow you to go back to the previous screen.

⊙ If two (2) remote controllers are connected to one (1) inside unit, only the master controller is available for trial operation and confirmation of operation data. (The slave remote controller is not available.)

Number	Data Item
01	☼ (Operation Mode)
02	SET TEMP (Set Temperature)
03	RETURN AIR (Return Air Temperature)
04	SENSOR (Remote Controller Thermistor Temperature)
05	THI-R1 (Indoor Heat Exchanger Thermistor / U Bend)
06	THI-R2 (Indoor Heat Exchanger Thermistor /Capillary)
07	THI-R3 (Indoor Heat Exchanger Thermistor /Gas Header)
08	I/U FANSPEED (Indoor Unit Fan Speed)
09	DEMAND (Frequency Requirements)
10	ANSWER (Response Frequency)
11	I/U EEV (Pulse of Indoor Unit Expansion Value)
12	TOTAL I/U RUN (Total Running Hours of The Indoor Unit)
21	OUTDOOR (Outdoor Air Temperature)
22	THO-R1 (Outdoor Heat Exchanger Thermistor)
23	THO-R2 (Outdoor Heat Exchanger Thermistor)
24	COMP (Compressor Frequency)
25	HP (High Pressure)
26	LP (Low Pressure)
27	Td (Discharge Pipe Temperature)
28	COMP BOTTOM (Comp Bottom Temperature)
29	CT (Current)
30	TARGET SH (Target Super Heat)
31	SH (Super Heat)
32	TDSH (Discharge Pipe Super Heat)
33	PROTECTION No.
34	O/U FANSPEED (Outdoor Unit Fan Speed)
35	63H1 (63H1 On/Off)
36	DEFROST (Defrost Control On/Off)
37	TOTAL COMP RUN (Total Running Hours of The Compressor)
38	O/U EEV1 (Pulse of The Outdoor Unit Expansion Valve EEVC)
39	O/U EEV2 (Pulse of The Outdoor Unit Expansion Valve EEVH)

●Details of Compressor protection status No. 33

No.	Contents of display	In case of FDC100-140 refer to
"0"	Normal	
"1"	Discharge pipe temperature protection control	P.25, (f.1).a)
"2"	Discharge pipe temperature anomaly	P.25, (f.1).b)
"3"	Current safe control of inverter primary current	P.27, (f.7)
"4"	High pressure protection control	P.25, (f.2).a), P.26, (f.3).a)
"5"	High pressure anomaly	P.25, (f.2).b)
"6"	Low pressure protection control	P.26, (f.5).a)
"7"	Low pressure anomaly	P.26, (f.5).b)
"8"	Anti-frost prevention control	P.27, (f.11)
"9"	Current cut	P.27, (f.7)
"10"	Power transistor protection control	P.27, (f.8)
"11"	Power transistor anomaly (Overheat)	P.27, (f.9)
"12"	Compression ratio control	P.26, (f.6)
"13"	Spare	
"14"	Dewing prevention control	P.28, (f.12)
"15"	Current safe control of inverter secondary current	P.27, (f.7)
"16"	Stop by compressor rotor lock	
"17"	Stop by compressor startup failure	P.28, (f.17)

- Note(1) Operation data display on the remote controller.
 •Data is displayed until canceling the protection control.
 • In case of multiple protections controlled, only the younger No. is displayed.
- Note(2) Common item.
 ① In heating mode.
 During protection control by the command signal for reducing compressor frequency from indoor unit, No. "4" is displayed.
 ② In cooling and dehumidifying mode.
 During protection control by the command signal for reducing compressor frequency from indoor unit, No. "8" is displayed.

(6) Inspection display of wireless specification model (FDEN, FDT)

(a) Display

1) FDEN Series

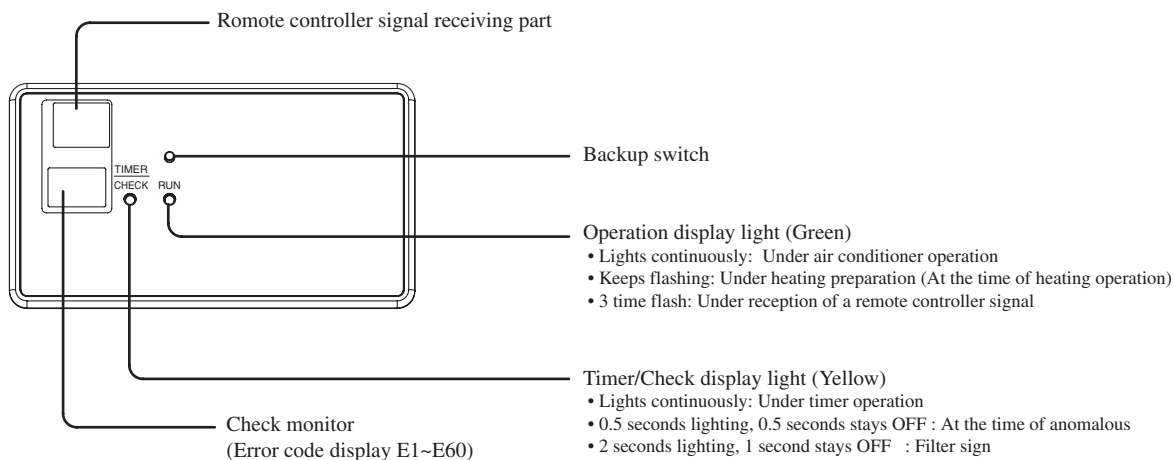

2) FDT (Wireless kit)

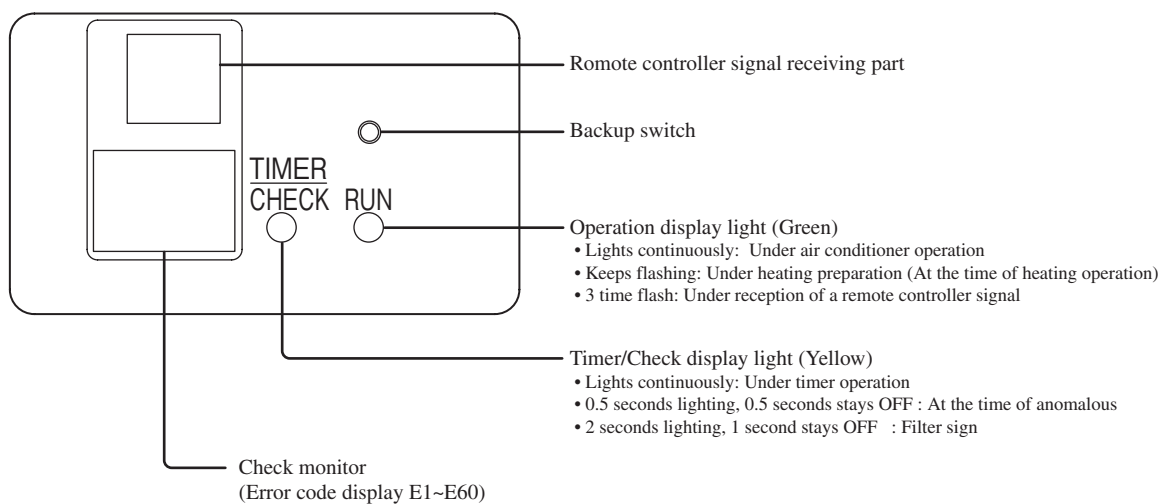

(7) Power transistor module (including the driver PCB) inspection procedure

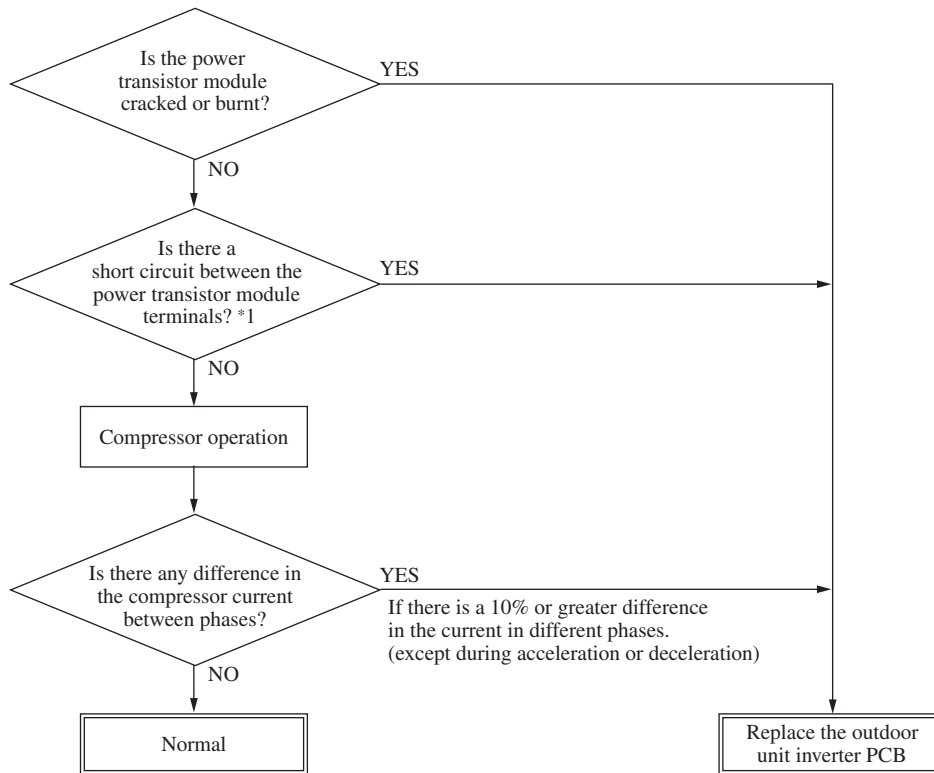

*1 Power transistor module terminal short circuit check procedure

Disconnect the compressor wiring, then conduct a short circuit check.

P-U, P-V, P-W

N-U, N-V, N-W

Check between the P-N terminals.

Bring the tester probes in contact with the following places on each terminal.

P: Power transistor P terminal,

N: Power transistor N terminal,

U: End of red harness to compressor

V: End of white harness to compressor

W: End of black or blue harness to compressor

Check for a power transistor short circuit.

- When you do not have a diagnostic checker for judging if the inverter is defective, measure between the terminals of the power transistor parts, judge whether the power transistor is defective or not.
- Disconnect the compressor, then measure with the controller incorporated.

Tester		Normal values (Ω)		
Terminal (+)	Terminal (-)	Model 71	Model 100~140	Model 200, 250
P	N	0 ~ (Numerical value rises.)	Approx. 1 M Approx. 300~400	Scores of M
N	P			A few of M
P	U	Several M (Numerical value rises.)	0	Scores of M
P	V			Scores of M
P	W			Scores of M
N	U	Approx. 650 k	Approx. 1.2 M	Hundreds of K
N	V			Hundreds of K
N	W			Hundreds of K
U	P	Approx. 670 k	Approx. 1.3 M	Hundreds of K
V	P	Approx. 4.4 M		Hundreds of K
W	P	Approx. 4.4 M		Hundreds of K
U	N	Approx. 650 k	0	Scores of M
V	N	Approx. 4.8 M		Scores of M
W	N	Approx. 4.9 M		Scores of M

If the measured values range from 0 ~ several kW, there is a possibility that the elements are damaged, so replace the power transistor parts.

(8) Inverter checker for diagnosis of inverter output

● Checking method

(a) Model: SRC40ZIX-S, 50ZIX-S, 60ZIX-S

1) Setup procedure of checker.

- a) Power OFF (Turn off the breaker).
- b) Remove the terminal cover of compressor and disconnect the wires (U, V, W) from compressor.
- c) Connect the wires U (Red) , V (White) and W (Black) of the checker to the terminal of disconnected wires (U, V, W) from compressor respectively.

2) Operation for judgment.

- a) Power ON and start check operation on cooling or heating mode.
- b) Check ON/OFF status of 6 LED's on the checker.
- c) Judge the PCB by ON/OFF status of 6 LED's on the checker.

ON/OFF status of LED	If all of LED are ON/OFF according to following pattern	If all of LED stay OFF or some of LED are ON/OFF
Inverter PCB	Normal	Anomalous

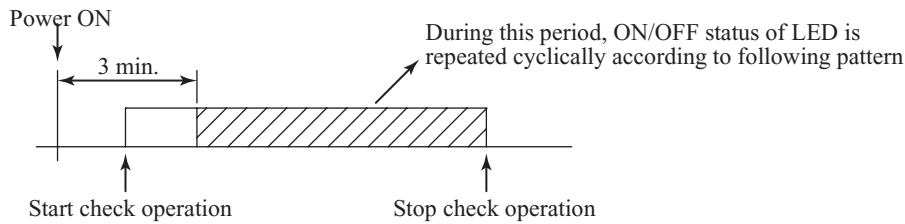

d) Stop check operation within about 2minutes after starting check operation.

(b) Model: FDC71VN, 100VN, 125VN, 140VN,100VS, 125VS, 140VS, 200VS, 250VS

1) Setup procedure of checker.

- a) Power OFF (Turn off the breaker).
- b) Remove the terminal cover of compressor and disconnect the wires (U, V, W) from compressor.
- c) Connect the wires U (Red) , V (White) and W (Black) of checker to the terminal of disconnected wires (U, V, W) from compressor respectively.

2) Operation for judgment.

- a) Power ON after JSW10-4 on outdoor inverter PCB was turned ON. (In case of FDC71-140)
* In case of FDC200VS and 250VS, Start test operation on cooling or heating mode after power ON.
- b) After 15 seconds since power has turned ON (or In case of FDC200VS, 250VS after the test operation started), LED start ON/OFF for 5 seconds cyclically and it repeats 10 times.
- c) Check ON/OFF status of 6 LED's on the checker.
- d) Judge the PCB by ON/OFF status of 6 LED's on the checker.

ON/OFF status of LED	If all of LED are ON/OFF according to following pattern	If all of LED stay OFF or some of LED are ON/OFF
Inverter PCB	Normal	Anomalous

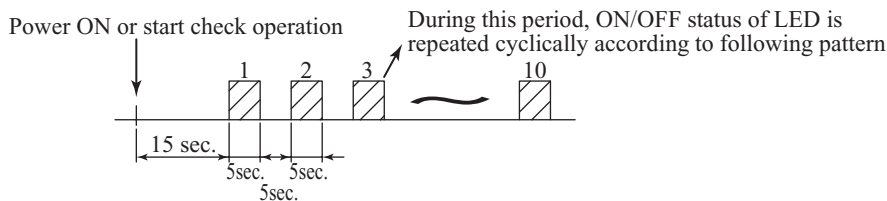

e) Be sure to turn off JSW10-4 on outdoor inverter PCB, after finishing the check operation. (In case of FDC71-140)

<Inverter Checker>

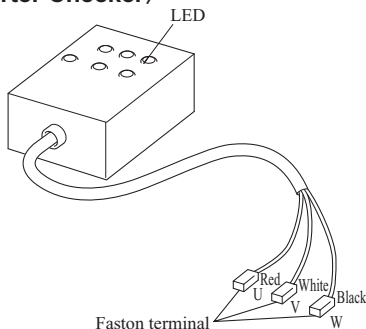

LED ON/OFF pattern

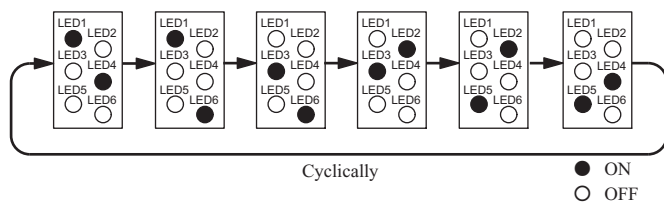

Connect to the terminal of the wires which are disconnected from compressor.

Models SRC40,50,60ZIX-S

●Outdoor unit check points

Check items with the *mark when the power is ON.

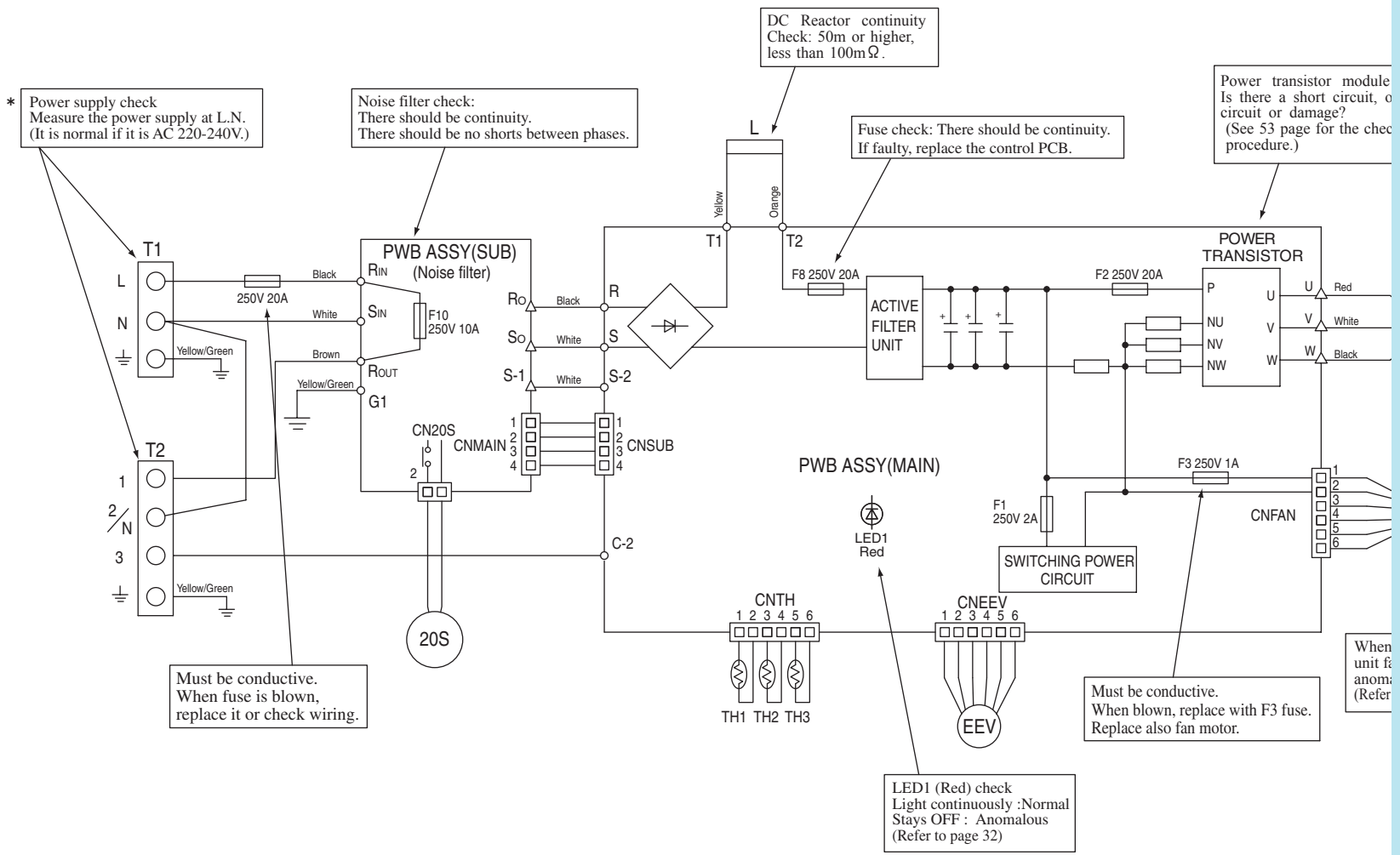

* Power supply check
Measure the power supply at L.N.
(It is normal if it is AC 220-240V.)

Noise filter check:
There should be continuity.
There should be no shorts between phases.

DC Reactor continuity
Check: 50m or higher,
less than 100mΩ.

Fuse check: There should be continuity.
If faulty, replace the control PCB.

Power transistor module
Is there a short circuit, or
circuit or damage?
(See 53 page for the check
procedure.)

Must be conductive.
When fuse is blown,
replace it or check wiring.

Must be conductive.
When blown, replace with F3 fuse.
Replace also fan motor.

LED1 (Red) check
Light continuously :Normal
Stays OFF : Anomalous
(Refer to page 32)

When unit fails
anomalously
(Refer to page 4)

Всe каталоги и инструкции здесь: <http://splitoff.ru/ehh-doc.html>

Model FDC71VN

●Outdoor unit check points

Check items with the *mark when the power is ON.

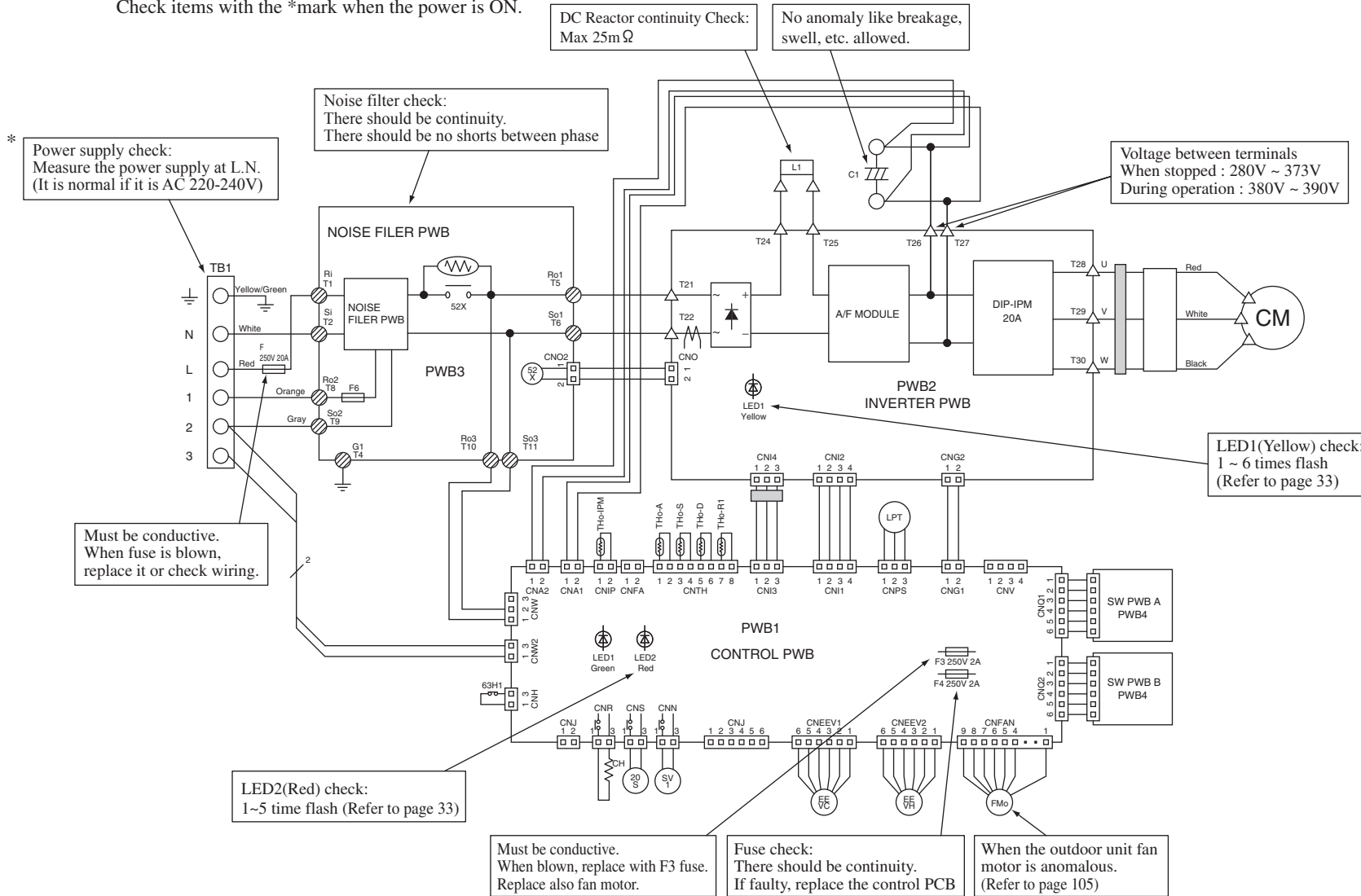

Models FDC100,125,140VN

●Outdoor unit check points

Check items with the *mark when the power is ON.

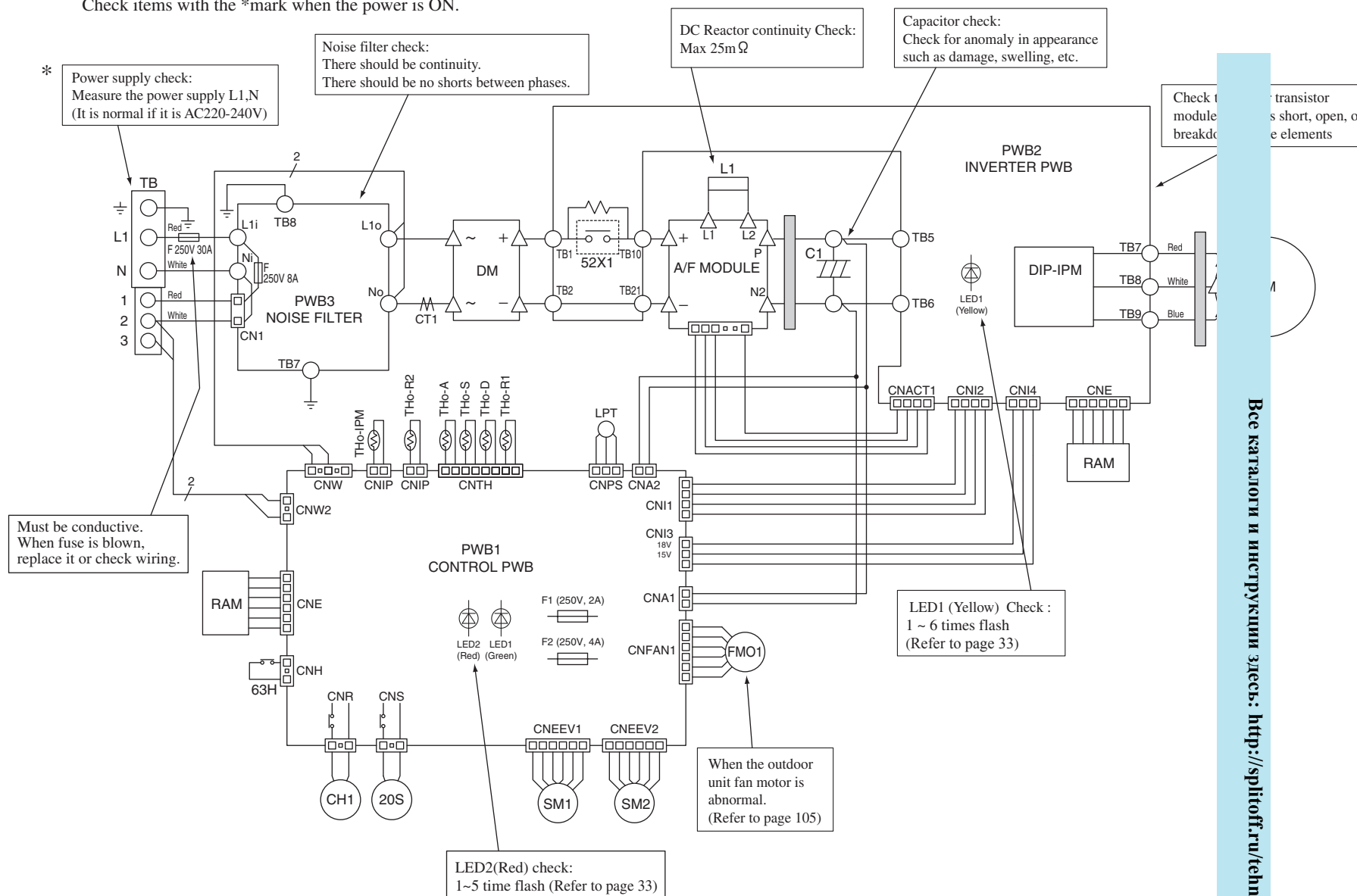

Все каталоги и инструкции здесь: <http://splitoff.ru/ehd-doc.html>

FDC100,125,140VS

Outdoor unit check points

Check items with the *mark when the power is ON.

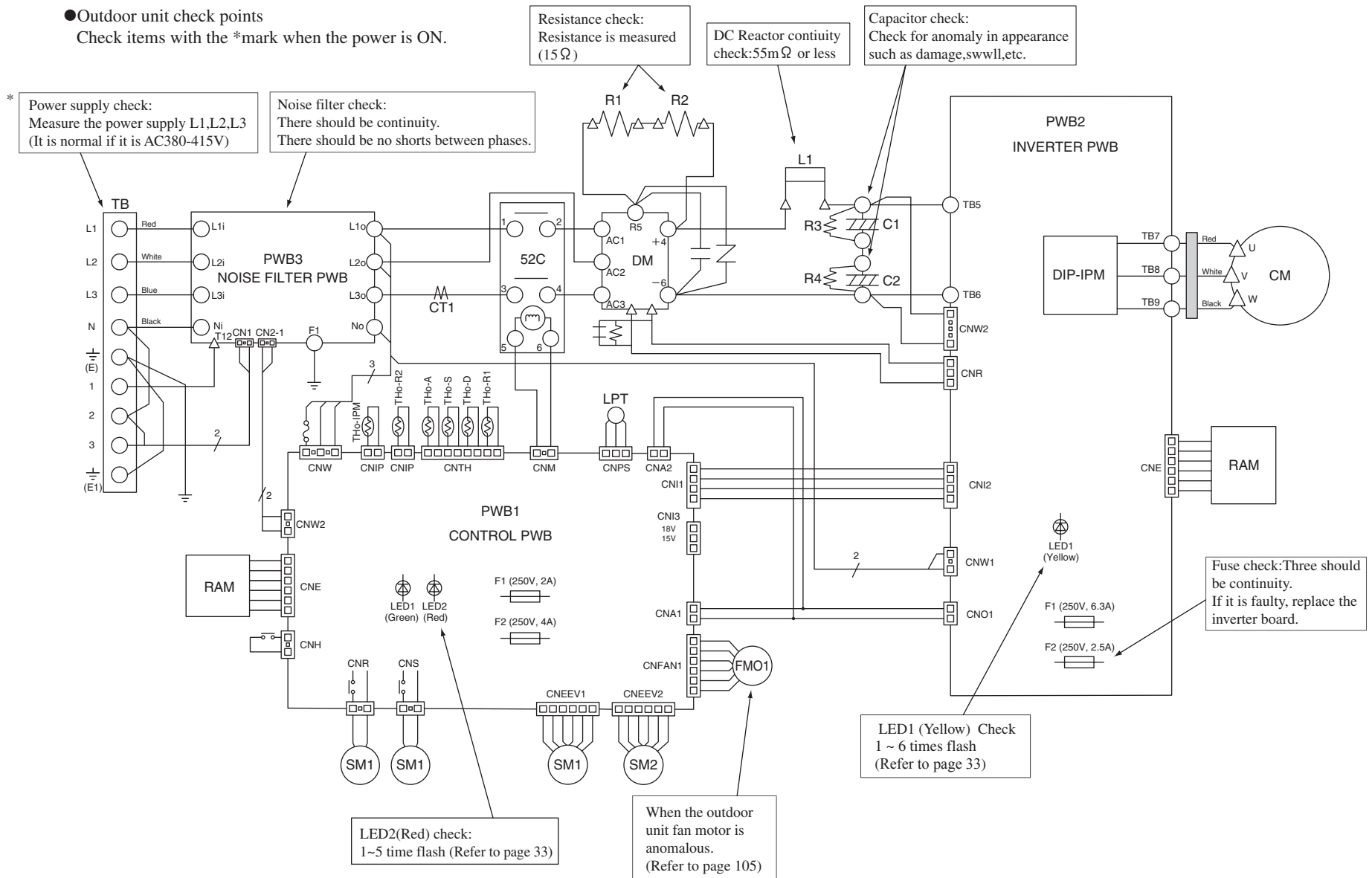

Models FDC200,250VS

●Outdoor unit check points

Check items with the *mark when the power is ON.

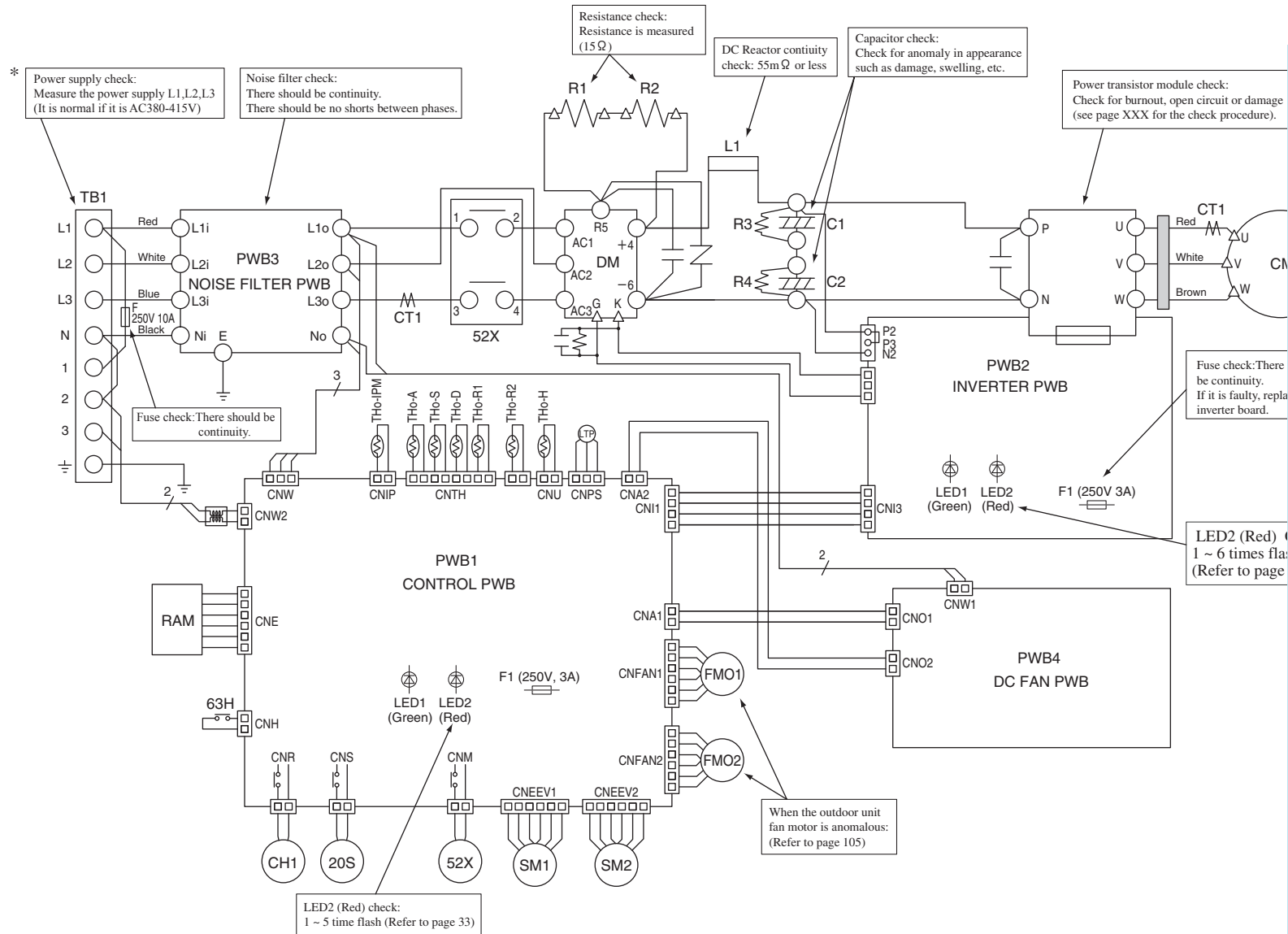

2.2 Troubleshooting flow

(1) List of troubles

No.	Remote controller display	Description of trouble	Reference page
1	None	Operates but does not cool.	61
			62
			63
4	None	Excessive noise/vibration (1/3)	64
5	None	Excessive noise/vibration (2/3)	65
6	None	Excessive noise/vibration (3/3)	66
7	None	Louver motor failure (FDT, FDTC and FDEN series)	67
8	None	Power supply system error (Power supply to indoor control PCB)	68
9	None	Power supply system error (Power supply to remote controller)	69
10	INSPECT I/U	INSPECT I/U (When 1 or 2 remote controllers are connected)	70
11	INSPECT I/U	INSPECT I/U (Connection of 3 units or more remote controllers)	71
12	🔊WAIT🔊	Communication error at initial operation (Models SRC40~60 only)	72~74
13	🔊WAIT🔊	Communication error at initial operation (Models FDC71~250 only)	75~77
14	None	No display (Models FDC71~250 only)	78
15	E1	Remote controller communication circuit error	79
16	E5	Communication error during operation	80
17	E6	Indoor heat exchanger temperature thermistor anomaly	81
18	E7	Return air temperature thermistor anomaly	82
19	E8	Heating overload operation	83
20	E9	Drain trouble (FDT, FDTC, FDU and FDUM series)	84
21	E10	Excessive number of connected indoor units (more than 17 units) by controlling with one remote controller	85
22	E14	Communication error between master and slave indoor units	86
23	E16	Indoor fan motor anomaly (In case of FDTC and FDT)	87
24	E19	Indoor unit operation check, drain motor check setting error	88
25	E28	Remote controller temperature thermistor anomaly	89
26	E34	Open L3 phase on power supply (3-phase model only)	90
27	E35	Cooling overload operation (Models SRC40~60 only)	91
28	E35	Cooling overload operation (Models FDC71~250 only)	92
29	E36	Discharge pipe temperature error	93
30	E37	Outdoor heat exchanger temperature thermistor anomaly	94
31	E38	Outdoor air temperature thermistor anomaly	95
32	E39	Discharge pipe temperature thermistor anomaly	96
33	E40	High pressure error (63H1 activated) (Models FDC71~250 only)	97
34	E41	Power transistor overheat (Models FDC 200, 250 only)	98
35	E42	Current cut	99 • 100
36	E45	Inverter communication error (Models FDC71~250 only)	101
37	E47	Inverter over-current error (Models SRC40~60 only)	102
38	E48	Outdoor fan motor anomaly (Models SRC40~60 only)	104
39	E48	Outdoor fan motor anomaly (Models FDC71~250 only)	105
40	E49	Low pressure error or low pressure sensor anomaly (Models FDC71~250 only)	106, 107
41	E51	Power transistor anomaly (Models SRC40~60 only)	108
42	E51	Inverter and fan motor anomaly (Models FDC71~250 only)	109
43	E53	Suction pipe temperature thermistor anomaly (Models FDC71~250 only)	110
44	E54	Low pressure sensor anomaly (Models FDC71~250 only)	111
45	E55	Underneath temperature thermistor anomaly (Models FDC 200, 250 only)	112
46	E57	Insufficient refrigerant amount or detection of service valve closure (Models SRC40~60 only)	113
47	E57	Insufficient refrigerant amount or detection of service valve closure (Models FDC71~250 only)	114
48	E58	Current safe stop (Models SRC40~60 only)	115
49	E59	Compressor startup failure (Models SRC40~60 only)	116
50	E59	Compressor startup failure (Models FDC71~250 only)	117
51	E60	Anomalous compressor rotor lock (Models SRC40~60, FDC 200, 250 only)	118

(2) Troubleshooting

Error code Remote controller: None	LED	Green	Red	Content Operates but does not cool
	Indoor	Keeps flashing	Stays OFF	
	Outdoor	Keeps flashing	Stays OFF	

Все каталоги и инструкции здесь: <http://splitoff.ru/tehn-doc.html>

1. Applicable model	5. Troubleshooting	
All models	Diagnosis	Countermeasure
2. Error detection method	<pre> graph TD Start[Check the indoor unit fan operation. Check the temperature difference between return and supply air.] --> D1{Is the temperature difference between return and supply air 10-20degC at cooling?} D1 -- YES --> D2{Does the heat load increase after installation?} D1 -- NO --> D3{Is the compressor operating?} D2 -- NO --> C1[It is normal. (This unit is designed to start in the soft start mode by detecting the under dome temperature of compressor when it restart after power reset.)] D2 -- YES --> B1[Mistake in model selection. Calculate heat load once more.] --> C2[It is necessary to replace to higher capacity one or to install additional unit.] D3 -- NO --> D4{"WAIT" message is displayed (for 3 seconds) when performing cooling, defrosting and heating operations from the remote controller.} D3 -- YES --> D5{Is the compressor rotation speed low?} D4 -- YES --> C3[Compressor refrigerant oil protection control at starting is activated. For the contents of control, refer to the compressor start control of the microcomputer control functions.] D4 -- NO --> C4[Compressor may be stopped by the error detection control. For the contents of control, refer to anomalous stop control by controlling compressor rotation speed of microcomputer control functions.] D5 -- NO --> C5[Inspect the followings. • Minor clogging of filter • Minor clogging of heat exchanger • Minor short-circuit • Minor shortage of refrigerant amount • Poor compression of compressor] D5 -- YES --> B2[Check which control "Determination control of compressor rotation speed" or "Protective control by controlling compressor rotation speed" is appropriate to this phenomenon.] B2 --> D6{Are the temperature conditions of room and outdoor air close to the rated conditions? (1)} D6 -- YES --> C6[Considering appropriate operation control, check suspicious points. Inspect the followings for reference. • Major clogging of filter • Major clogging of heat exchanger • Major short-circuit • Major shortage of refrigerant amount • Compressor protection ON • Indoor fan tap • Valid setting of silent mode] D6 -- NO --> B3[The unit is operating normally but is operating under the control for protecting compressor or other respective parts.] </pre>	
3. Condition of Error displayed		
4. Presumable cause		

Note:

Error code Remote controller: None	LED	Green	Red	Content Operates but does not heat
	Indoor	Keeps flashing	Stays OFF	
	Outdoor	Keeps flashing	Stays OFF	

Все каталоги и инструкции здесь: <http://splitoff.ru/tehn-doc.html>

1. Applicable model	2. Troubleshooting	
All models	Diagnosis	Countermeasure
2. Error detection method	<pre> graph TD Start[Check the indoor unit fan operation. Check the temperature difference between return and supply air.] --> D1{Is the temperature difference between return and supply air 10-30degC at heating?} D1 -- YES --> D2{Does the heat load increase after installtion?} D1 -- NO --> D3{Is the compressor operating?} D2 -- YES --> B1[Mistake in model selection. Calculate heat load once again.] D2 -- NO --> D3 D3 -- NO --> D4{"⌚WAIT⌚" message is displayed (for 3 seconds) when performing cooling, defrosting and heating operations from the remote controller.} D3 -- YES --> D5{Is the compressor rotation speed low?} D4 -- YES --> C1[Compressor refrigerant oil protection control at starting is activated. For the contents of control, refer to the compressor start control of the microcomputer control functions.] D4 -- NO --> D5 D5 -- NO --> C2[Inspect the followings. • Minor clogging of filter • Minor clogging of heat exchanger • Minor short-circuit • Minor shortage of refrigerant amount • Poor compression of compressor] D5 -- YES --> B2[Check which control "Determination control of compressor rotation speed" or "Protective control by controlling compressor rotation speed" is appropriate to this phenomenon.] B2 --> D6{Are the (1) temperature conditions of room and outdoor air close to the rated conditions?} D6 -- YES --> C3[Considering appropriate operation control, check suspicious points. Inspect the followings for reference. • Major clogging of filter • Major clogging of heat exchanger • Major short-circuit • Major shortage of refrigerant amount • Compressor protection ON • Indoor fan tap • Valid setting of silent mode] D6 -- NO --> B3[The unit is operating normally but is operating under the contol for protecting compressor or other respective parts.] </pre>	
3. Condition of Error displayed		
4. Presumable cause		
<ul style="list-style-type: none"> Faulty 4-way valve operation Poor compression of compressor Faulty expansion valve operation 		

Note:

Error code Remote controller: None	LED	Green	Red	Content Earth leakage breaker activated
	Indoor	Stays OFF	Stays OFF	
	Outdoor	Stays OFF	Stays OFF	

Все каталоги и инструкции здесь: <http://splitoff.ru/tehn-doc.html>

1. Applicable model All models	2. Troubleshooting	
2. Error detection method	Diagnosis	Countermeasure
3. Condition of Error displayed	<pre> graph TD D1{Are OK the insulation resistance and coil resistance of compressor?} -- NO --> C1[Replace compressor.*] D1 -- YES --> D2{Is insulation of respective harnesses OK? Is any harness bitten between panel and casing or etc?} D2 -- NO --> C2[Secure insulation resistance.] D2 -- YES --> P1[Check the outdoor unit grounding wire/earth leakage breaker.] P1 --> D3[Check of the outdoor unit grounding wire/earth leakage breaker] </pre> <p>Check of the outdoor unit grounding wire/earth leakage breaker</p> <ol style="list-style-type: none"> ① Run an independent grounding wire from the grounding screw of outdoor unit to the grounding terminal on the distribution panel. (Do not connect to another grounding wire.) ② In order to prevent malfunction of the earth leakage breaker itself, confirm that it is conformed to higher harmonic regulation. <p>* Insulation resistance of compressor</p> <ul style="list-style-type: none"> • Immediately after installation or when the unit has been left for long time without power supply, the insulation resistance may drop to a few MΩ because of refrigerant migrated in the compressor. <p>When the earth breaker is activated at lower insulation resistance, check the following points.</p> <ol style="list-style-type: none"> ① 6 hours after power ON, check if the insulation resistance recovers to normal. When power ON, crankcase heater heat up compressor and evaporate the refrigerant migrated in the compressor. ② Check if the earth leakage breaker is conformed to higher harmonic regulation or not. <p>Since the unit is equipped with inverter, it is necessary to use components conformed to higher harmonic regulation in order to prevent malfunction of earth leakage breaker.</p>	
4. Presumable cause	<ul style="list-style-type: none"> • Defective compressor • Noise 	

Note:

Error code Remote controller: None	LED	Green	Red	Content Excessive noise/vibration (1/3)
	Indoor	—	—	
	Outdoor	—	—	

Все каталоги и инструкции здесь: <http://splitoff.ru/tehn-doc.html>

1. Applicable model	2. Troubleshooting	
All models	Diagnosis	Countermeasure
2. Error detection method	<pre> graph TD D1{Does noise/vibration occur during or soon after stopping operation of air-conditioner?} D2{[Installation work] Does noise/vibration occur not only from the air-conditioner but also from entire building?} D3{Does the installation of indoor/outdoor unit loose?} D4{Are pipes touching the wall, etc?} D5{[Product] Does noise/vibration occur from operating fan (fan only)?} D6{Is there a fan or louver touching other components?} C1[To 2/3] C2[If excessive noise/vibration persists when sufficient time has elapsed after stopping the unit, it is considered that the air-conditioner is not the source.] C3[Check the installed condition carefully, and correct the position or insert rubber cushions or others into the gap, if necessary.] C4[Prevent the vibration from transmitting to wall and etc by fixing pipes on the wall or wrapping rubber cushion around the pipe which goes through the hole in the wall or applying other appropriate means.] C5[Strength of ceiling wall, floor, etc. may be insufficient. Review the installing position or reinforce it.] C6[Check for leaning of installed unit or anomalous mounting of fan, louver or motor and specify the contacting point and correct it.] C7[When the heat exchanger or filter is clogged, clean them. In case that the unit is installed at the site where background noise is very low, small noise from indoor unit can be heard, but it is normal. Before installation, check for background noise. If background noise is very low, convince client prior to installation.] D1 -- NO --> C1 D1 -- YES --> D2 D2 -- YES --> D3 D2 -- NO --> D4 D3 -- YES --> C2 D3 -- NO --> D4 D4 -- YES --> C3 D4 -- NO --> C4 D5 -- YES --> D6 D5 -- NO --> C1 D6 -- YES --> C5 D6 -- NO --> C6 </pre>	
3. Condition of Error displayed		
4. Presumable cause		
<ul style="list-style-type: none"> ① Improper installation work <ul style="list-style-type: none"> • Improper anti-vibration work at installation • Insufficient strength of mounting face ② Defective product <ul style="list-style-type: none"> • Before/after shipping from factory ③ Improper adjustment during commissioning <ul style="list-style-type: none"> • Excess/shortage of refrigerant, etc. 		

Note:

Error code Remote controller: None	LED	Green	Red	Content Excessive noise/vibration (2/3)
	Indoor	-	-	
	Outdoor	-	-	

Все каталоги и инструкции здесь: <http://splitoff.ru/tehn-doc.html>

1. Applicable model	2. Troubleshooting	
All models	Diagnosis	Countermeasure
2. Error detection method	<pre> graph TD Start([From 1/3]) --> D1{[Unit side] Does noise/vibration occur when the cooling/heating operation is performed normally?} D1 -- YES --> D2{Are the pipes contacting the casing?} D1 -- NO --> End([To 3/3]) D2 -- YES --> C1[Rearrange the piping to avoid contact with the casing.] D2 -- NO --> D3{Is it heard continuous hissing or roaring sound?} D3 -- YES --> C2[It is noise/vibration that is generated when the refrigerant gas or liquid flow through inside of piping of air-conditioner. It is likely to occur particularly during cooling or defrosting in the heating mode. It is normal.] D3 -- NO --> D4{Are hissing sounds heard at the startup or stopping?} D4 -- YES --> C3[The noise/vibration occurs when the refrigerant starts or stops flowing. It is normal.] D4 -- NO --> D5{Is blowing sound heard at the start/stop of defrosting during heating?} D5 -- YES --> C4[When the defrosting starts or stops during heating, the refrigerant flow is reversed due to switching 4-way valve. This causes a large change in pressure which produces a blowing sound. It may accompany also the hissing sounds as mentioned above. They are normal.] D5 -- NO --> D6{Is cracking noise heard during heating operation?} D6 -- YES --> C5[After the start or stop of heating operation or during defrosting, abrupt changes in temperature cause resin parts to shrink or expand. This is normal.] D6 -- NO --> D7{Hissing noise is heard during cooling operation or after stopping?} D7 -- YES --> C6[It is the sound produced by the drain pump that discharges drain from the indoor unit. The pump continues to run for 5 minutes after stopping the cooling operation. This is normal.] D7 -- NO --> C7[Apply the damper sealant at places considered to be the sources such as the pressure reducing mechanism (expansion valve), capillary, etc.] </pre>	
3. Condition of Error displayed		
4. Presumable cause		

Note:

Error code Remote controller: None	LED	Green	Red	Content Excessive noise/vibration (3/3)
	Indoor	–	–	
	Outdoor	–	–	

Все каталоги и инструкции здесь: <http://splitoff.ru/tehn-doc.html>

1. Applicable model	2. Troubleshooting	
All models	Diagnosis	Countermeasure
2. Error detection method		
3. Condition of Error displayed	<p>If insufficient cooling/heating problem happens due to anomalous operating conditions at cooling/heating, followings are suspicious.</p> <ul style="list-style-type: none"> • Overcharge of refrigerant • Insufficient charge of refrigerant • Intrusion of air, nitrogen, etc. <p>In such occasion, it is necessary to recover refrigerant, vacuum-dry and recharge refrigerant.</p> <p>* Since there could be many causes of noise/vibration, the above do not cover all. In such case, check the conditions when, where, how the noise/vibration occurs according to following check point.</p> <ul style="list-style-type: none"> • Indoor/outdoor unit • Cooling/heating/fan mode • Startup/stop/during operation • Operating condition (Indoor/outdoor temperatures, pressure) • Time it occurred • Operation data retained by the remote controller such as compressor rotation speed, heat exchanger temperature, EEV opening degree, etc. • Tone (If available, record the noise) • Any other anomalies 	
4. Presumable cause		

Note:

Error code Remote controller: None	LED	Green	Red	Content Louver motor failure (FDT, FDTC and FDEN series)
	Indoor	Keeps flashing	Stays OFF	
	Outdoor	Keeps flashing	Stays OFF	

Все каталоги и инструкции здесь: <http://splitoff.ru/tehn-doc.html>

1. Applicable model FDT, FDTC and FDEN series only	2. Troubleshooting	
2. Error detection method	Diagnosis	Countermeasure
3. Condition of Error displayed	<p>▲ Check at the indoor unit side.</p> <pre> graph TD Start[Operate after waiting for more than 1 minute.] --> Q1{Does the louver operate at the power on?} Q1 -- NO --> Q2{Is LM wiring broken?} Q2 -- YES --> C1[Repair wiring.] Q2 -- NO --> Q3{Is LM locked?} Q3 -- YES --> C2[Replace LM.] Q3 -- NO --> C3[Defective indoor control PCB → Replace.] Q1 -- YES --> Q4{Is the louver operable with the remote controller?} Q4 -- YES --> C4[Normal] Q4 -- NO --> C5[Adjust LM lever and then check again.] </pre> <p>LM: louver motor</p>	
4. Presumable cause	<ul style="list-style-type: none"> • Defective LM • LM wire breakage • Faulty indoor control PCB 	

Note:

Error code Remote controller: None	LED	Green	Red	Content Power supply system error (Power supply to indoor control PCB)
	Indoor	Stays OFF	Stays OFF	
	Outdoor	Stays OFF	2 times flash	

Все каталоги и инструкции здесь: <http://splitoff.ru/tehn-doc.html>

1. Applicable model	3. Troubleshooting	
All models	Diagnosis	Countermeasure
2. Error detection method	<pre> graph TD Q1{Is AC220/240V detected between 1 and 2 on the terminal block of indoor unit?} Q2{Is AC380/415V for 3-phase unit detected between 1, 2 and 3 on the terminal block of outdoor unit or is AC220/240V for 1-phase unit detected between 1 and 2 on the terminal block of outdoor unit?} Q3{Are fuses OK (2 pcs.)?} Q4{Is the check of resistance between ①-③ of CNW0 OK?} Q5{Is the checked result of resistance of FM, LM, etc OK?} Q6{Is DC5V detected between ④-⑤?} Q7{Is JX1 open?} Q8{Is AC19V or higher detected between Red-Red (CNW2) at transformer secondary side?} Q9{Is JX1 open?} Q1 -- NO --> C1[Defective outdoor control PCB (Noise filter)] Q1 -- YES --> Q2 Q2 -- NO --> C1 Q2 -- YES --> C2[Misconnection or breakage of connecting wires] Q3 -- NO --> Q4 Q3 -- YES --> Q6 Q4 -- NO --> C3[Defective indoor control or power PCB → Replace.] Q4 -- YES --> Q5 Q5 -- NO --> C4[Replace FM, LM, etc.] Q5 -- YES --> C5[Replace fuse.] Q6 -- NO --> C6[Defective indoor power PCB → Replace.] Q6 -- YES --> Q7 Q7 -- NO --> C7[Open JX1.] Q7 -- YES --> C8[Defective indoor control PCB → Replace.] Q8 -- NO --> C9[Replace transformer.] Q8 -- YES --> Q9 Q9 -- NO --> C7 Q9 -- YES --> C10[Defective indoor control PCB → Replace.] </pre>	
3. Condition of Error displayed		
4. Presumable cause		
<ul style="list-style-type: none"> Misconnection or breakage of connecting wires Blown fuse Faulty transformer Faulty indoor control or power PCB Broken harness Faulty outdoor control PCB (Noise filter) 		

Note:

Error code Remote controller: None	LED	Green	Red	Content Power supply system error (Power supply to remote controller)
	Indoor	Keeps flashing	Stays OFF	
	Outdoor	Keeps flashing	2 times flash	

Все каталоги и инструкции здесь: <http://splitoff.ru/tehn-doc.html>

1. Applicable model All models	2. Troubleshooting	
2. Error detection method	Diagnosis	Countermeasure
3. Condition of Error displayed		
4. Presumable cause	<ul style="list-style-type: none"> • Remote controller wire breakage/short-circuit • Defective remote controller • Malfunction by noise • Faulty indoor power PCB • Broken harness • Faulty indoor control PCB 	

Note:

Error code Remote controller: INSPECT I/U	LED	Green	Red	Content INSPECT I/U (When 1 or 2 remote controllers are connected)
	Indoor	Keeps flashing	Stays OFF	
	Outdoor	Keeps flashing	2 times flash	

Все каталоги и инструкции здесь: <http://splitoff.ru/tehn-doc.html>

1. Applicable model		2. Troubleshooting	
All models		Diagnosis	Countermeasure
<p>2. Error detection method</p> <p>Communication between indoor unit and remote controller is disabled for more than 30 minutes after the power on.</p>		<pre> graph TD Q1{Are 2 units of remote controller connected?} Q2{Is it set at the slave remote controller?} Q3{Does it become normal?} Q4{Do more than one indoor units have the same address?} Q5{Are remote controller wires laid along high voltage wires?} Q6{Does DM start 60 seconds later automatically.} Q1 -- YES --> S1[Set one remote controller for "Master" and the other for "Slave"] S1 -- Note (1) Use SW1 to set at master or slave. --> Q3 Q3 -- NO --> Q4 Q1 -- NO --> Q2 Q2 -- YES --> C1[Set SW1 on remote controller PCB at "Master".] Q2 -- NO --> Q3 Q4 -- YES --> C2[Set address again. (SW2 on indoor control PCB)] Q4 -- NO --> Q5 Q5 -- YES --> C3[Separate remote controller wires from high voltage wires.] Q5 -- NO --> S2[Disconnect the connecting wire ③ between the indoor and outdoor unit.] S2 --> S3[Power supply reset] S3 --> Q6 Q6 -- YES --> C4[Defective indoor control PCB -> Replace.] Q6 -- NO --> C5[Defective remote controller -> Change.] </pre>	<p>3. Condition of Error displayed</p> <p>Same as above</p>
<p>4. Presumable cause</p> <ul style="list-style-type: none"> • Improper setting • Surrounding environment • Defective remote controller communication circuit • Faulty indoor control PCB 			<p>Countermeasure</p>

Note: If any error is detected 30 minutes after displaying “WAIT” on the remote controller, the display changes to “INSPECT I/U”.

Error code	LED	Green	Red	Content
	Indoor	Keeps flashing	Stays OFF	
	Outdoor	Keeps flashing	2 times flash	

INSPECT I/U
(Connection of 3 units or more remote controller)

Все каталоги и инструкции здесь: <http://splitoff.ru/tehn-doc.html>

1. Applicable model	2. Troubleshooting	
All models	Diagnosis	Countermeasure
2. Error detection method		
Indoor unit cannot communicate for more than 30 minutes after the power on with remote controller.		
3. Condition of Error displayed		
Same as above		
4. Presumable cause		
<ul style="list-style-type: none"> • Improper setting • Surrounding environment • Defective remote controller communication circuit • Faulty indoor control or power PCB • Faulty outdoor control PCB 		

Note: If any error is detected 30 minutes after displaying “WAIT” on the remote controller, the display changes to “INSPECT I/U”.

Error code Remote controller: 🟡WAIT🟡	LED	Green	Red	Content Communication error at initial operation (1/3) (Model SRC40 - 60)
	Indoor	Keeps flashing	Stays OFF	
	Outdoor	—	2 times flash	

Все каталоги и инструкции здесь: <http://splitoff.ru/tehn-doc.html>

1. Applicable model Model SRC40 – 60 When the remote controller LCD displays “🟡WAIT🟡” 2 minutes after the power on.
2. Error detection method
3. Condition of Error displayed
4. Presumable cause <ul style="list-style-type: none"> • Blown fuse • Faulty outdoor power PCB • Connection between PCB's • Blown fuse on single phase model • Faulty indoor control PCB • Defective remote controller • Broken remote controller wire • Faulty outdoor control PCB

Diagnosis	Countermeasure
<p>The remote controller LCD displays “🟡WAIT🟡” 2 minutes after the power on.</p> <p>Turn the breaker off once and then back on again 3 minutes later.</p> <p>Is normal condition restored?</p> <p>NO →</p> <p>Isn't blown the power supply fuse (20A) on the outdoor unit controller?</p> <p>NO → Replace the power supply fuse.</p> <p>YES →</p> <p>Is AC220/240V detected at the secondary side of outdoor power PCB?</p> <p>NO → Defective outdoor power PCB → Replace.</p> <p>YES →</p> <p>Are OK the connection wires between the outdoor power and the control PCB'S?</p> <p>NO → Connect properly.</p> <p>YES →</p> <p>Isn't F10 fuse (250V, 10A) blown.</p> <p>NO → Replace fuse.</p> <p>YES →</p> <p>Is the green LED of indoor unit flashing?</p> <p>NO → Defective indoor control PCB → Replace.</p> <p>YES →</p> <p>Is the red LED of indoor unit flashing twice?</p> <p>NO → Replace indoor control PCB. Defective remote controller → Replace. Broken remote controller wire Y → Replace.</p> <p>YES →</p> <p>Are wires connected properly between the indoor and the outdoor units?</p> <p>NO → Correct connection wires between indoor and outdoor units.</p> <p>YES →</p> <p>Is approx. DC20V detected between ②-③ on the outdoor unit terminal block?</p> <p>NO → Defective outdoor control PCB → Replace.</p> <p>YES →</p> <p>Is approx. DC20V detected between ②-③ on the indoor unit terminal block?</p> <p>NO → Defective connection wire (broken wire) Noise</p> <p>YES → Defective indoor control PCB → Replace.</p>	<p>See next page.</p> <p>Defective outdoor power PCB → Replace.</p> <p>Connect properly.</p> <p>Replace fuse.</p> <p>Defective indoor control PCB → Replace.</p> <p>Replace indoor control PCB. Defective remote controller → Replace. Broken remote controller wire Y → Replace.</p> <p>Correct connection wires between indoor and outdoor units.</p> <p>Defective outdoor control PCB → Replace.</p> <p>Defective connection wire (broken wire) Noise</p> <p>Defective indoor control PCB → Replace.</p>

Note: If any anomaly is detected during communication, the error code E5 is displayed. (Outdoor unit red LED flashes twice.) Inspection procedure is same as above. (Excluding matters related to connection) When the power supply is reset after the occurrence of E5, the LED will display “🟡WAIT🟡” if the anomaly continues. If the breaker ON/OFF is repeated in a short period of time (within 1 minute), “🟡WAIT🟡” may be displayed. In such occasion, turn the breaker off and wait for 3 minutes.

Error code Remote controller: 🗄️ WAIT 🗄️	LED	Green	Red	Content Communication error at initial operation (2/3) (Model SRC40 - 60)
	Indoor	Keeps flashing	Stays OFF	
	Outdoor	–	2 times flash	

Все каталоги и инструкции здесь: <http://splitoff.ru/tehn-doc.html>

1. Applicable model	5. Troubleshooting	
<p>Model SRC40 – 60</p> <p>When the fuse is blown, the method to inspect inverter before replacing the power supply fuse</p>	Diagnosis	Countermeasure
2. Error detection method	<pre> graph TD D1{Isn't there a short-circuit between phases of outdoor power PCB?} A1[Replace the outdoor power PCB] D2{Aren't there cracks or burning on the power transistor module or diode stack?} A2[Replace the outdoor control PCB] D3{Isn't reactor the anomalous?} A3[Replace the reactor.] A4[Replace fuse.] D1 -- NO --> A1 D1 -- YES --> D2 D2 -- NO --> A2 D2 -- YES --> D3 D3 -- NO --> A3 D3 -- YES --> A4 </pre>	
3. Condition of Error displayed		
4. Presumable cause	<ul style="list-style-type: none"> • Blown fuse • Faulty outdoor power PCB • Faulty outdoor control PCB • Faulty reactor 	

Note:

Error code Remote controller: WAIT	LED	Green	Red	Content Communication error at initial operation (3/3) (Model SRC40 - 60)
	Indoor	Keeps flashing	Stays OFF	
	Outdoor	—	2 times flash	

Все каталоги и инструкции здесь: <http://splitoff.ru/tehn-doc.html>

1. Applicable model	3. Troubleshooting		
Model SRC40 – 60	Diagnosis	Countermeasure	
When the remote controller display is extinguished after the power on.	<pre> graph TD Start[Remote controller display is extinguished after the power on.] --> D1{Is the green LED on the indoor unit flashing?} D1 -- NO --> D2{Is the fuse on the indoor control PCB OK?} D2 -- NO --> C1[Replace fuse.] D2 -- YES --> D3{Is AC (1) 19V or higher detected between Red-Red at the secondary side of indoor unit transformer?} D3 -- NO --> C2[Defective transformer] D3 -- YES --> D4{Is approx. 10-11V detected between wires at the remote controller side after disconnecting the remote controller?} D4 -- NO --> C3[Short-circuit on remote controller wire] D4 -- YES --> C4[Defective remote controller] D1 -- YES --> D5{Is the red LED in the outdoor unit flashing twice?} D5 -- NO --> C5[Defective indoor control PCB → Replace. Defective remote controller Broken remote controller wire X or Y] D5 -- YES --> D6{Are wires connected properly between the indoor and the outdoor units?} D6 -- NO --> C6[Correct wires.] D6 -- YES --> D7{Is approx. DC20V detected between ②N-③ on the outdoor unit terminal block?} D7 -- NO --> C7[Defective outdoor power PCB → Replace.] D7 -- YES --> D8{Is approx. DC20V detected between ②-③ on the indoor unit terminal block?} D8 -- NO --> C8[Defective connection wire (Broken wire) Noise] D8 -- YES --> C9[Defective indoor control PCB → Replace.] </pre>		
2. Error detection method			
3. Condition of Error displayed			
4. Presumable cause			

Note:

Error code Remote controller: 🟡WAIT🟡	LED	Green	Red	Content Communication error at initial operation (1/3) (Model FDC71 - 250)
	Indoor	Keeps flashing	Stays OFF	
	Outdoor	Keeps flashing	2 times flash	

Все каталоги и инструкции здесь: <http://splitoff.ru/tehn-doc.html>

1. Applicable model	3. Troubleshooting			
Model FDC71 – 250	Diagnosis	Countermeasure		
2. Error detection method	<pre> graph TD Start[“WAIT” is still displayed on the remote controller LED 2 minutes after power ON.] -- YES --> D1{Is the outdoor unit control green LED flashing?} D1 -- NO --> A{A} D1 -- YES --> D2{Is the indoor unit green LED flashing?} D2 -- NO --> C1[Defective indoor control PCB -> Replace.] D2 -- YES --> D3{Is the outdoor unit control red LED flashing twice?} D3 -- NO --> C2[Defective indoor control PCB -> Replace. Defective remote controller -> Replace. Broken remote controller wire Y -> Replace.] D3 -- YES --> D4{Are wires connected properly between indoor/outdoor units?} D4 -- NO --> C3[Correct connection wires between indoor and outdoor units.] D4 -- YES --> D5{Is approx. DC20V detected between ②-③ on the outdoor unit terminal block?} D5 -- NO --> C4[Defective outdoor control PCB -> Replace.] D5 -- YES --> D6{Is approx. DC20V detected between ②-③ on the indoor unit terminal block?} D6 -- YES --> C5[Defective connection wire (Broken) Noise Defective indoor control or power PCB -> Replace.] D6 -- NO --> C5 A --> C6[See next page.] </pre>			
3. Condition of Error displayed				
4. Presumable cause			<ul style="list-style-type: none"> • Faulty indoor control or power PCB • Defective remote controller • Broken remote controller wire • Faulty outdoor control PCB • Broken connection wires 	

Note:

Error code Remote controller: 🗸 WAIT 🗸	LED	Green	Red	Content Communication error at initial operation (2/3) (Model FDC71 - 250)
	Indoor	Keeps flashing	Stays OFF	
	Outdoor	Keeps flashing	2 times flash	

Все каталоги и инструкции здесь: <http://splitoff.ru/tehn-doc.html>

1. Applicable model	3. Troubleshooting	
Model FDC71 - 250	Diagnosis	Countermeasure
2. Error detection method		
3. Condition of Error displayed		
4. Presumable cause		
<ul style="list-style-type: none"> Faulty noise filter Faulty indoor control PCB Faulty outdoor control PCB Faulty inverter PCB Faulty fan motor 		

Note:

Error code Remote controller: 🗸 WAIT 🗸	LED	Green	Red	Content Communication error at initial operation (3/3) (Model FDC71 - 250)
	Indoor	Keeps flashing	Stays OFF	
	Outdoor	Keeps flashing	2 times flash	

Все каталоги и инструкции здесь: <http://splitoff.ru/tehn-doc.html>

1. Applicable model	3. Troubleshooting	
Model FDC71 - 250	Diagnosis	Countermeasure
2. Error detection method	<pre> graph TD Start[Method to check for inverter PCB before replacement of blown power supply fuse.] --> D1{Isn't there a short-circuit between phases of the noise filter?} D1 -- YES --> R1[Replace the noise filter.] D1 -- NO --> D2{Isn't there a short-circuit between phases of inverter PCB input terminals?} D2 -- YES --> R2[Replace the inverter PCB.] D2 -- NO --> D3{Isn't there any crack, burning on the power transistor module?} D3 -- YES --> R3[Replace the inverter PCB. (1)] D3 -- NO --> D4{Is the reactor OK?} D4 -- NO --> R4[Replace the reactor.] D4 -- YES --> D5{Is the electrolytic capacitor OK?} D5 -- NO --> R5[Replace the electrolytic capacitor.] D5 -- YES --> R6[Replace the power supply fuse.] </pre> <p>Note (1) For model 200, 250 replace also the power transistor module.</p>	
3. Condition of Error displayed		
4. Presumable cause		

Note:

Error code Remote controller: None	LED	Green	Red	Content No display (Model FDC71 – 250)
	Indoor	Keeps flashing	Stays OFF	
	Outdoor	Keeps flashing	2 times flash	

Все каталоги и инструкции здесь: <http://splitoff.ru/tehn-doc.html>

1. Applicable model Model FDC71 - 250	2. Troubleshooting	
2. Error detection method	Diagnosis	Countermeasure
3. Condition of Error displayed	<pre> graph TD Start[Remote controller does not display anything after the power on.] --> D1{Is DC10V or higher detected at remote controller connection terminals?} D1 -- YES --> C1[Defective remote controller] D1 -- NO --> D2{Is DC10V or higher detected on remote controller wires if the remote controller is removed?} D2 -- YES --> C2[Defective remote controller] D2 -- NO --> D3{Are wires connected properly between the indoor/outdoor units?} D3 -- YES --> C3[Defective connecting wire. Defective remote controller wire (Short-circuit, etc.)] D3 -- NO --> C4[Defective indoor control PCB -> Replace.] </pre>	
4. Presumable cause	<ul style="list-style-type: none"> • Faulty indoor control PCB • Defective remote controller • Broken remote controller wire 	

Note:

Error code Remote controller: E1	LED	Green	Red	Content Remote controller communication circuit error
	Indoor	Keeps flashing	Stays OFF	
	Outdoor	Keeps flashing	Stays OFF	

Все каталоги и инструкции здесь: <http://splitoff.ru/tehn-doc.html>

1. Applicable model	2. Troubleshooting	
All models	Diagnosis	Countermeasure
2. Error detection method	<pre> graph TD A{Is it possible to reset normally by the power reset?} -- YES --> B[Malfunction by noise Check peripheral environment.] A -- NO --> C[Turn SW7-1 to OFF. → ON Remove the wire ③ connecting between indoor/outdoor units.] C --> D[Power reset] D --> E{Does the drain pump restart automatically 1 minute later?} E -- YES --> F[Defective indoor control PCB → Replace.] E -- NO --> G[Defective remote controller → Replace.] </pre> <p>Note (2) Does the remote controller still display “WAIT” even after 3 minutes?</p>	
When normal communication between the remote controller and the indoor unit is interrupted for more than 2 minutes. (Detectable only with the remote controller)		
3. Condition of Error displayed		
Same as above		
4. Presumable cause	<ul style="list-style-type: none"> • Defective communication circuit between remote controller-indoor unit • Noise • Defective remote controller • Faulty indoor control PCB 	

Note: If the indoor unit cannot communicate normally with the remote controller for 180 seconds, the indoor unit PCB starts to reset automatically.

Error code Remote controller: E5	LED	Green	Red	Content Communication error during operation
	Indoor	Keeps flashing	2{6} times flash	
	Outdoor	Keeps flashing	See below	

Все каталоги и инструкции здесь: <http://splitoff.ru/tehn-doc.html>

1. Applicable model	2. Troubleshooting	
All models	Diagnosis	Countermeasure
2. Error detection method	<p>In case that the outdoor unit red LED flashes 2{6}-times</p> <p>Note (1) Inspect faulty connections (disconnection, looseness) on the outdoor unit terminal block.</p> <p>Is the connection of signal wires at the outdoor unit side OK?</p> <p>NO → Repair signal wires.</p> <p>YES</p> <p>Note (2) Check for faulty connection or breakage of signal wires between indoor-outdoor units.</p> <p>Is the connection of signal wires between indoor-outdoor units OK?</p> <p>NO → Repair signal wires.</p> <p>YES</p> <p>Power reset</p> <p>Has the remote controller LCD returned to normal state?</p> <p>NO → To the diagnosis of “WAIT”</p> <p>YES → Unit is normal. (Malfunction by temporary noise, etc.)</p>	
3. Condition of Error displayed	<p>In case that the outdoor unit red LED stays OFF</p> <p>Power reset</p> <p>NO</p> <p>Has the remote controller LCD returned to normal state?</p> <p>NO → Defective outdoor control PCB (Defective network communication circuit) → Replace.</p> <p>YES → Unit is normal. (Malfunction by temporary noise, etc.)</p>	
3. Condition of Error displayed		
Same as above is detected during operation.		
4. Presumable cause		
<ul style="list-style-type: none"> • Unit No. setting error • Broken remote controller wire • Faulty remote controller wire connection • Faulty outdoor control PCB 		

Note: Pressing the pump-down switch cancels communications between indoor and outdoor unit so that “communication error-E5” is displayed on indoor unit and remote controller, but it is normal.

Error code Remote controller: E6	LED	Green	Red	Content Indoor heat exchanger temperature thermistor anomaly
	Indoor	Keeps flashing	1 time flash	
	Outdoor	Keeps flashing	Stays OFF	

Все каталоги и инструкции здесь: <http://splitoff.ru/tehn-doc.html>

<p>1. Applicable model</p> <p>All models</p>	<p>2. Troubleshooting</p>	
<p>2. Error detection method</p> <p>Anomalously low temperature or high temperature (resistance) is detected on the indoor heat exchanger thermistor (ThI-R1, R2 or R3).</p>	<p style="text-align: center;">Diagnosis</p>	<p style="text-align: center;">Countermeasure</p>
<p>3. Condition of Error displayed</p> <ul style="list-style-type: none"> When the temperature thermistor detects -50°C or lower for 5 seconds continuously, the compressor stops. After 3-minutes delay, the compressor starts again automatically, but if this error occurs again within 60 minutes after the initial detection. Or if 70°C or higher is detected for 5 seconds continuously. 	<p>(Broken wire) Temperature-resistance characteristic</p> <p>(Shot circuit)</p>	
<p>4. Presumable cause</p> <ul style="list-style-type: none"> Defective indoor heat exchanger thermistor connector Indoor heat exchanger temperature thermistor anomaly Faulty indoor control PCB 		

Note:

Error code Remote controller: E7	LED	Green	Red	Content Return air temperature thermistor anomaly
	Indoor	Keeps flashing	1 time flash	
	Outdoor	Keeps flashing	Stays OFF	

Все каталоги и инструкции здесь: <http://splitoff.ru/tehn-doc.html>

1. Applicable model All models	2. Troubleshooting																	
2. Error detection method Anomalously low temperature or high temperature (resistance) is detected by indoor return air temperature thermistor (Thi-A)	Diagnosis	Countermeasure																
3. Condition of Error displayed <ul style="list-style-type: none"> When the temperature thermistor detects -50°C or lower for 5 seconds continuously, the compressor stops. After 3-minute delay, the compressor starts again automatically, but if this error occurs again within 60 minutes after the initial detection. 	<pre> graph TD D1{Is the connection of return air temperature thermistor connector OK?} D2{Are the characteristics of return air temperature thermistor OK?} C1[Correct. -> Connect connector.] C2[Defective return air temperature thermistor -> Replace.] C3[Defective indoor control PCB -> Replace. (Defective return air temperature thermistor input circuit)] D1 -- NO --> C1 D1 -- YES --> D2 D2 -- NO --> C2 D2 -- YES --> C3 </pre>																	
4. Presumable cause <ul style="list-style-type: none"> Defective return air temperature thermistor connector Defective return air temperature thermistor Faulty indoor control PCB 	<p>Temperature-resistance characteristic</p> <table border="1"> <caption>Temperature-resistance characteristic data points (approximate)</caption> <thead> <tr> <th>Temperature (°C)</th> <th>Resistance (kΩ)</th> </tr> </thead> <tbody> <tr><td>0</td><td>15</td></tr> <tr><td>10</td><td>10</td></tr> <tr><td>20</td><td>7</td></tr> <tr><td>25</td><td>5</td></tr> <tr><td>30</td><td>4</td></tr> <tr><td>40</td><td>3</td></tr> <tr><td>50</td><td>2</td></tr> </tbody> </table>		Temperature (°C)	Resistance (kΩ)	0	15	10	10	20	7	25	5	30	4	40	3	50	2
Temperature (°C)	Resistance (kΩ)																	
0	15																	
10	10																	
20	7																	
25	5																	
30	4																	
40	3																	
50	2																	

Note:

Error code Remote controller: E8	LED	Green	Red	Content Heating overload operation
	Indoor	Keeps flashing	1 time flash	
	Outdoor	Keeps flashing	Stays OFF	

Все каталоги и инструкции здесь: <http://splitoff.ru/tehn-doc.html>

<p>1. Applicable model</p> <p>All models</p>	<p>2. Troubleshooting</p> <table border="1"> <thead> <tr> <th>Diagnosis</th> <th>Countermeasure</th> </tr> </thead> <tbody> <tr> <td> </td> <td></td> </tr> </tbody> </table> <p>Note (1) Judge if it is in the state of overload or not as follows. ▲ Is there any short-circuit of air? ▲ Isn't there any fouling or clogging on the indoor heat exchanger? ▲ Is the outdoor fan control normal? ▲ Isn't the room and outdoor air temperature too high?</p> <p>Note (2) For characteristics of indoor heat exchanger temperature thermistor, see the error display E6.</p>	Diagnosis	Countermeasure		
Diagnosis	Countermeasure				
<p>2. Error detection method</p> <p>Indoor heat exchanger temperature thermistor (ThI-R1, R2, R3)</p>					
<p>3. Condition of Error displayed</p> <p>When it is detected 5 times within 60 minutes from initial detection or when the overload condition is detected for 6 minutes continuously.</p>					
<p>4. Presumable cause</p> <ul style="list-style-type: none"> • Clogged air filter • Defective indoor heat exchanger temperature thermistor connector • Defective indoor heat exchanger temperature thermistor • Anomalous refrigerant system 					

Note: During heating operation; After starting compressor, compressor rotation speed is decreased by detecting indoor heat exchanger temperature (Thi-R) in order to control high pressure.

Error code Remote controller: E9	LED	Green	Red	Content Drain trouble (FDT, FDTC, FDU, and FDUM series)
	Indoor	Keeps flashing	1 time flash	
	Outdoor	Keeps flashing	Stays OFF	

Все каталоги и инструкции здесь: <http://splitoff.ru/tehn-doc.html>

1. Applicable model	2. Troubleshooting	
FDT, FDTC, FDU and FDUM series only	Diagnosis	Countermeasure
2. Error detection method	<pre> graph TD Start[Check the error data in the remote controller.] --> D1{Is there any overflow?} D1 -- NO --> D2{Is DC 12V at CNI connector. (1)} D2 -- YES --> C1[Check float switch.] D2 -- NO --> D3{Is the CNI connected firmly?} D3 -- NO --> C2[Defective indoor control PCB → Replace.] D3 -- YES --> D4{Is there any anomaly on the optional equipment?} D4 -- NO --> C3[Defective indoor control PCB → Replace.] D4 -- YES --> C4[Check optional equipment] D1 -- YES --> D5{Is the humidifier connected?} D5 -- YES --> D6{Is the humidifier Drain Motor interlocked by the indoor unit function setting of remote controller?} D6 -- NO --> C5[Correct setting to "Humidifier DM interlock".] D6 -- YES --> S1[Drain motor ON from the remote controller] S1 --> D7{Does DM operate?} D7 -- NO --> D8{Is AC220/240V detected at CNR connector?} D8 -- NO --> C6[Defective indoor control PCB → Replace. (Replace power PCB on FDT and FDTC Series.) Check wiring of Drain motor] D8 -- YES --> D9{Is the drain piping unclogged? Is the drain pipe slop OK?} D9 -- NO --> C7[Correct.] D9 -- YES --> C8[Check drain motor.] </pre>	
3. Condition of Error displayed		
4. Presumable cause		

Note: When this error occurred at power ON, disconnection of wire or connector of the float switch is suspected. Check and correct it (or replace it, if necessary).

Error code Remote controller: E10	LED	Green	Red	Content Excessive number of connected indoor units (more than 17 units) by controlling with one remote controller
	Indoor	Keeps flashing	Stays OFF	
	Outdoor	Keeps flashing	Stays OFF	

Все каталоги и инструкции здесь: <http://splitoff.ru/tehn-doc.html>

1. Applicable model	2. Troubleshooting	
All models	Diagnosis	Countermeasure
2. Error detection method	<pre> graph TD A{Aren't more than 17 indoor units connected to one remote controller?} -- NO --> B[Defective remote controller -> Replace.] A -- YES --> C[Reduce to 16 or less units.] </pre>	
When it detects more than 17 of indoor units connected to one remote controller		
3. Condition of Error displayed		
Same as above		
4. Presumable cause		
<ul style="list-style-type: none"> Excessive number of indoor units connected Defective remote controller 		

Note:

Error code Remote controller: E14	LED	Green	Red	Content Communication error between master and slave indoor units
	Indoor	Keeps flashing	3 times flash	
	Outdoor	Keeps flashing	Stays Off	

Все каталоги и инструкции здесь: <http://splitoff.ru/tehn-doc.html>

<p>1. Applicable model</p> <p>All models</p>	<p>3. Troubleshooting</p>																																
<p>2. Error detection method</p> <p>When communication error between master and slave indoor units occurs</p>	<table border="1"> <thead> <tr> <th data-bbox="517 436 1150 510">Diagnosis</th> <th data-bbox="1150 436 1447 510">Countermeasure</th> </tr> </thead> <tbody> <tr> <td data-bbox="517 510 1150 696"> <pre> graph TD Q1{Is it OK the unit address setting for master and slave indoor units?} -- NO --> C1[Correct unit address setting.] Q1 -- YES --> Q2{Isn't the remote controller wiring between indoor units defective?} Q2 -- YES --> C2[Correct wiring.] Q2 -- NO --> Q3{Is it restored by resetting the power supply?} Q3 -- NO --> C3[Defective indoor control PCB -> Replace.] Q3 -- YES --> C4["• Malfunction by noise • Check surrounding environment."] </pre> </td> <td data-bbox="1150 510 1447 1982"></td> </tr> <tr> <td data-bbox="145 1211 488 1559"> <p>3. Condition of Error displayed</p> <p>Same as above</p> </td> <td colspan="2" data-bbox="517 1189 1447 1391"> <p>Note (1) Set dip switches SW5-1 and SW5-2 as shown in the following table. (Factory default setting – “Master”)</p> <table border="1"> <thead> <tr> <th colspan="2" rowspan="2"></th> <th colspan="4">Indoor unit</th> </tr> <tr> <th>Master</th> <th>Slave-a</th> <th>Slave-b</th> <th>Slave-c</th> </tr> </thead> <tbody> <tr> <td rowspan="2">Dip switch</td> <td>SW5-1</td> <td>OFF</td> <td>OFF</td> <td>ON</td> <td>ON</td> </tr> <tr> <td>SW5-2</td> <td>OFF</td> <td>ON</td> <td>OFF</td> <td>ON</td> </tr> </tbody> </table> </td> </tr> <tr> <td data-bbox="145 1581 488 1982"> <p>4. Presumable cause</p> <ul style="list-style-type: none"> • Unit address setting error • Broken remote controller wire • Defective remote controller wire connection • Defective indoor control PCB </td> <td colspan="2"></td> </tr> </tbody> </table>		Diagnosis	Countermeasure	<pre> graph TD Q1{Is it OK the unit address setting for master and slave indoor units?} -- NO --> C1[Correct unit address setting.] Q1 -- YES --> Q2{Isn't the remote controller wiring between indoor units defective?} Q2 -- YES --> C2[Correct wiring.] Q2 -- NO --> Q3{Is it restored by resetting the power supply?} Q3 -- NO --> C3[Defective indoor control PCB -> Replace.] Q3 -- YES --> C4["• Malfunction by noise • Check surrounding environment."] </pre>		<p>3. Condition of Error displayed</p> <p>Same as above</p>	<p>Note (1) Set dip switches SW5-1 and SW5-2 as shown in the following table. (Factory default setting – “Master”)</p> <table border="1"> <thead> <tr> <th colspan="2" rowspan="2"></th> <th colspan="4">Indoor unit</th> </tr> <tr> <th>Master</th> <th>Slave-a</th> <th>Slave-b</th> <th>Slave-c</th> </tr> </thead> <tbody> <tr> <td rowspan="2">Dip switch</td> <td>SW5-1</td> <td>OFF</td> <td>OFF</td> <td>ON</td> <td>ON</td> </tr> <tr> <td>SW5-2</td> <td>OFF</td> <td>ON</td> <td>OFF</td> <td>ON</td> </tr> </tbody> </table>				Indoor unit				Master	Slave-a	Slave-b	Slave-c	Dip switch	SW5-1	OFF	OFF	ON	ON	SW5-2	OFF	ON	OFF	ON	<p>4. Presumable cause</p> <ul style="list-style-type: none"> • Unit address setting error • Broken remote controller wire • Defective remote controller wire connection • Defective indoor control PCB 		
Diagnosis	Countermeasure																																
<pre> graph TD Q1{Is it OK the unit address setting for master and slave indoor units?} -- NO --> C1[Correct unit address setting.] Q1 -- YES --> Q2{Isn't the remote controller wiring between indoor units defective?} Q2 -- YES --> C2[Correct wiring.] Q2 -- NO --> Q3{Is it restored by resetting the power supply?} Q3 -- NO --> C3[Defective indoor control PCB -> Replace.] Q3 -- YES --> C4["• Malfunction by noise • Check surrounding environment."] </pre>																																	
<p>3. Condition of Error displayed</p> <p>Same as above</p>	<p>Note (1) Set dip switches SW5-1 and SW5-2 as shown in the following table. (Factory default setting – “Master”)</p> <table border="1"> <thead> <tr> <th colspan="2" rowspan="2"></th> <th colspan="4">Indoor unit</th> </tr> <tr> <th>Master</th> <th>Slave-a</th> <th>Slave-b</th> <th>Slave-c</th> </tr> </thead> <tbody> <tr> <td rowspan="2">Dip switch</td> <td>SW5-1</td> <td>OFF</td> <td>OFF</td> <td>ON</td> <td>ON</td> </tr> <tr> <td>SW5-2</td> <td>OFF</td> <td>ON</td> <td>OFF</td> <td>ON</td> </tr> </tbody> </table>				Indoor unit				Master	Slave-a	Slave-b	Slave-c	Dip switch	SW5-1	OFF	OFF	ON	ON	SW5-2	OFF	ON	OFF	ON										
		Indoor unit																															
		Master	Slave-a	Slave-b	Slave-c																												
Dip switch	SW5-1	OFF	OFF	ON	ON																												
	SW5-2	OFF	ON	OFF	ON																												
<p>4. Presumable cause</p> <ul style="list-style-type: none"> • Unit address setting error • Broken remote controller wire • Defective remote controller wire connection • Defective indoor control PCB 																																	

Note:

Error code Remote controller: E16	LED	Green	Red	Content Indoor fan motor anomaly (In case of FDTC and FDT)
	Indoor	Keeps flashing	Stays OFF	
	Outdoor	Keeps flashing	Stays OFF	

Все каталоги и инструкции здесь: <http://splitoff.ru/tehn-doc.html>

1. Applicable model	2. Troubleshooting					
FDTC, FDT series only	<table border="1"> <thead> <tr> <th data-bbox="518 434 1152 510">Diagnosis</th> <th data-bbox="1152 434 1450 510">Countermeasure</th> </tr> </thead> <tbody> <tr> <td data-bbox="518 510 1152 734"> </td> <td data-bbox="1152 510 1450 1984"></td> </tr> </tbody> </table>		Diagnosis	Countermeasure		
Diagnosis	Countermeasure					
2. Error detection method						
Detected by rotation speed of indoor fan motor						
3. Condition of Error displayed						
When actual rotation speed of indoor fan motor drops to lower than 200rpm for 30 seconds continuously, the compressor and the indoor fan motor stop. After 2-seconds, it starts again automatically, but if this error occurs 4 times within 60 minutes after the initial detection.						
4. Presumable cause						
<ul style="list-style-type: none"> • Defective indoor power PCB • Foreign material at rotational area of fan propeller • Defective fan motor • Dust on control PCB • Blown fuse • External noise, surge 						

Note:

Error code Remote controller: E19	LED	Green	Red	Content Indoor unit operation check, drain motor check setting error
	Indoor	Keeps flashing	1 time flash	
	Outdoor	Keeps flashing	Stays OFF	

Все каталоги и инструкции здесь: <http://splitoff.ru/tehn-doc.html>

1. Applicable model All models	2. Troubleshooting	
2. Error detection method After indoor operation check, when the communication between indoor and outdoor unit is established and SW7-1 is still kept ON.	Diagnosis	Countermeasure
3. Condition of Error displayed Same as above	<pre> graph TD Start[E19 occurs when the power ON] --> Decision{Is SW7-1 on the indoor control PCB ON?} Decision -- NO --> Countermeasure1[Defective indoor control PCB (Defective SW7) -> Replace] Decision -- YES --> Countermeasure2[Turn SW7-1 on the indoor control PCB OFF and reset the power] </pre>	
4. Presumable cause Mistake in SW7-1 setting (Due to forgetting to turn OFF SW7-1 after indoor operation check)		

Note:

Error code Remote controller: E28	LED	Green	Red	Content Remote controller temperature thermistor anomaly
	Indoor	Keeps flashing	Stays OFF	
	Outdoor	Keeps flashing	Stays OFF	

Все каталоги и инструкции здесь: <http://splitoff.ru/tehn-doc.html>

1. Applicable model
All models

2. Error detection method
Detection of anomalously low temperature (resistance) of remote controller temperature thermistor (Thc)

3. Condition of Error displayed
When the temperature thermistor detects -50°C or lower for 5 seconds continuously, the compressor stops. After 3-minutes delay, the compressor starts again automatically, but if this error occurs again within 60 minutes after the initial detection.

4. Presumable cause

- Faulty connection of remote controller temperature thermistor
- Defective remote controller temperature thermistor
- Defective remote controller PCB

5. Troubleshooting

Diagnosis	Countermeasure
-----------	----------------

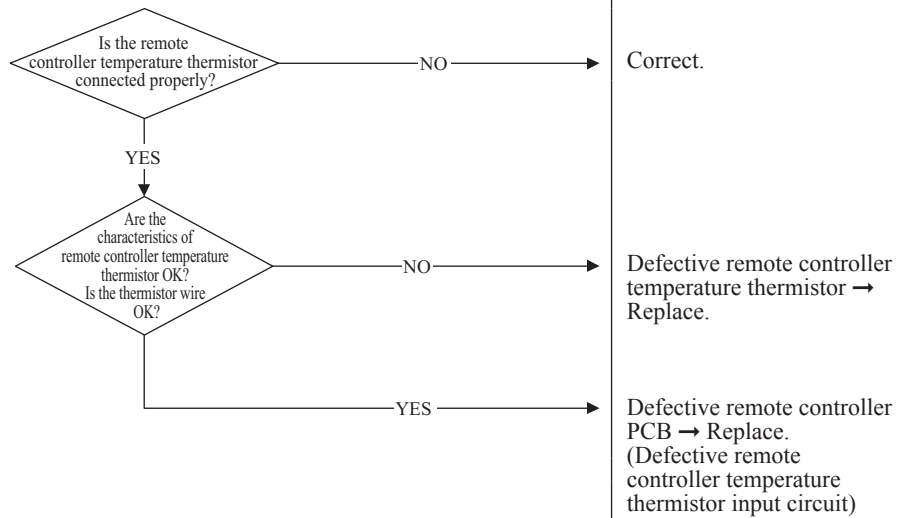

Resistance-temperature characteristics of remote controller temperature thermistor (ThC)

Temperature (°C)	Resistance value (kΩ)	Temperature (°C)	Resistance value (kΩ)
0	65	30	16
1	62	32	15
2	59	34	14
4	53	36	13
6	48	38	12
8	44	40	11
10	40	42	9.9
12	36	44	9.2
14	33	46	8.5
16	30	48	7.8
18	27	50	7.3
20	25	52	6.7
22	23	54	6.3
24	21	56	5.8
26	19	58	5.4
28	18	60	5.0

Note: After 10 seconds has passed since remote controller thermistor was switched from valid to invalid, E28 will not be displayed even if the thermistor harness is disconnected. At same time the thermistor, which is effective, is switched from remote controller thermistor to indoor return air temperature thermistor. Even though the remote controller thermistor is set to be Effective, the return air temperature displayed on remote controller for checking still shows the value detected by indoor return air temperature thermistor, not by remote controller temperature thermistor.

Error code Remote controller: E34	LED	Green	Red	Content Open L3 phase on power supply (3-phase model only)
	Indoor	Keeps flashing	Stays OFF	
	Outdoor	Keeps flashing	1 time flash	

Все каталоги и инструкции здесь: <http://splitoff.ru/tehn-doc.html>

<p>1. Applicable model</p> <p>3-phase models only</p>	<p>2. Error detection method</p> <p>When 0V is detected on any of L1, L2, L3 for 5 seconds continuously after turning power on.</p>				
<p>3. Condition of Error displayed</p> <p>Same as above</p>	<p>3. Troubleshooting</p> <table border="1" style="width: 100%;"> <thead> <tr> <th style="width: 70%;">Diagnosis</th> <th style="width: 30%;">Countermeasure</th> </tr> </thead> <tbody> <tr> <td style="text-align: center;"> <pre> graph TD D1{Measure the power supply voltage. Is AC380/415V between respective phases?} D2{Is AC380/415V detected between respective phases at the secondary side of noise filter?} D3{Is wiring between the noise filter and the outdoor control PCB connected properly?} D1 -- NO --> C1[Check power supply.] D1 -- YES --> D2 D2 -- NO --> C2[Replace noise filter.] D2 -- YES --> D3 D3 -- NO --> C3[Connect properly.] D3 -- YES --> C4[Defective outdoor control PCB -> Replace.] </pre> </td> <td></td> </tr> </tbody> </table>	Diagnosis	Countermeasure	<pre> graph TD D1{Measure the power supply voltage. Is AC380/415V between respective phases?} D2{Is AC380/415V detected between respective phases at the secondary side of noise filter?} D3{Is wiring between the noise filter and the outdoor control PCB connected properly?} D1 -- NO --> C1[Check power supply.] D1 -- YES --> D2 D2 -- NO --> C2[Replace noise filter.] D2 -- YES --> D3 D3 -- NO --> C3[Connect properly.] D3 -- YES --> C4[Defective outdoor control PCB -> Replace.] </pre>	
Diagnosis	Countermeasure				
<pre> graph TD D1{Measure the power supply voltage. Is AC380/415V between respective phases?} D2{Is AC380/415V detected between respective phases at the secondary side of noise filter?} D3{Is wiring between the noise filter and the outdoor control PCB connected properly?} D1 -- NO --> C1[Check power supply.] D1 -- YES --> D2 D2 -- NO --> C2[Replace noise filter.] D2 -- YES --> D3 D3 -- NO --> C3[Connect properly.] D3 -- YES --> C4[Defective outdoor control PCB -> Replace.] </pre>					
<p>4. Presumable cause</p> <ul style="list-style-type: none"> • Anomalous power supply • Blown power supply fuse • Defective noise filter • Defective wire connection on noise filter control PCB • Defective outdoor control PCB 					

Note:

Error code Remote controller: E35	LED	Green	Red	Content Cooling overload operation (Model SRC40 - 60 only)
	Indoor	Keeps flashing	Stays OFF	
	Outdoor	—	2 times flash	

Все каталоги и инструкции здесь: <http://splitoff.ru/tehn-doc.html>

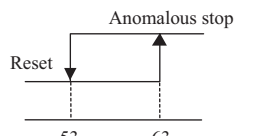
<p>1. Applicable model</p> <p>Model SRC40 – 60</p>	<p>5. Troubleshooting</p>	
<p>2. Error detection method</p>  <p>Outdoor heat exchanger temperature (°C)</p>	<p>Diagnosis</p> <pre> graph TD Q1{Are normal the characteristics of outdoor heat exchanger temperature thermistor normal?} Q2{Is the unit operating in the state of cooling overload?} Q3{Is the high pressure control normal?} Q4{Is the temperature (measured actually) at direction of error correct?} Q1 -- NO --> C1[Replace outdoor heat exchanger temperature thermistor.] Q1 -- YES --> Q2 Q2 -- YES --> C2["Check unit side. • Isn't the air circulation of outdoor unit short-circuited? • Are installation spaces adequate? • Isn't there any fouling or clogging on heater exchanger?"] Q2 -- NO --> Q3 Q3 -- NO --> C3[Control operation check*] Q3 -- YES --> Q4 Q4 -- NO --> C4[Defective outdoor control PCB → Replace.] Q4 -- YES --> C5["Excessive refrigerant amount: Recharge refrigerant by weighing proper amount on a scale."] </pre> <p>* For the characteristics of outdoor heat exchanger temperature thermistor, refer to E37.</p>	<p>Countermeasure</p>
<p>3. Condition of Error displayed</p> <p>When anomalous outdoor heat exchanger temperature occurs 5 times within 60 minutes or 63°C or higher continues for 10 minutes, including the compressor stop.</p>		
<p>4. Presumable cause</p> <ul style="list-style-type: none"> • Defective outdoor heat exchanger temperature thermistor • Defective outdoor control PCB • Indoor, outdoor unit installation spaces • Short-circuit of air on indoor, outdoor units • Fouling, clogging of heat exchanger • Excessive refrigerant quantity 		

Note:

Error code Remote controller: E35	LED	Green	Red	Content Cooling overload operation (Model FDC71 - 250 only)
	Indoor	Keeps flashing	Stays OFF	
	Outdoor	Keeps flashing	1 time flash	

Все каталоги и инструкции здесь: <http://splitoff.ru/tehn-doc.html>

<p>1. Applicable model</p> <p>Model FDC71 – 250</p>	<p>3. Troubleshooting</p>	
<p>2. Error detection method</p> <p>For the error detection method, refer to the protective control by controlling compressor rotation speed and cooling high pressure protective control of micro computer control function for corresponding models.</p>	<p style="text-align: center;">Diagnosis</p> <pre> graph TD Q1{Are the characteristics of outdoor heat exchanger temperature thermistor normal?} Q2{Is the unit operating in the state of cooling overload?} Q3{Is the high pressure control normal?} Q4{Is the temperature (measured actually) at detection of error correct?} Q1 -- NO --> C1[Replace outdoor heat exchanger temperature thermistor.] Q1 -- YES --> Q2 Q2 -- YES --> C2[Check unit side. • Isn't the air circulation of outdoor unit short-circuited? • Are installation spaces adequate? • Isn't there any fouling or clogging on heat exchanger?] Q2 -- NO --> Q3 Q3 -- NO --> C3[Control operation check *] Q3 -- YES --> Q4 Q4 -- NO --> C4[Defective outdoor control PCB -> Replace.] Q4 -- YES --> C5[Excessive refrigerant amount : Recharge refrigerant by weighing proper amount on a scale.] </pre>	<p style="text-align: center;">Countermeasure</p>
<p>3. Condition of Error displayed</p> <p>When outdoor heat exchanger temperature anomaly is detected 5 times within 60 minutes or this anomalous state is detected 60 minutes continuously including compressor stop.</p>		
<p>4. Presumable cause</p> <ul style="list-style-type: none"> • Defective outdoor heat exchanger temperature thermistor • Defective outdoor control PCB • Indoor, outdoor unit installation spaces • Short-circuit of air on indoor, outdoor units • Fouling, clogging of heat exchanger • Excessive refrigerant amount 	<p>* For the contents of control, refer to the protective control by controlling compressor rotation speed and cooling high pressure protective control of micro computer control function for corresponding models.</p>	

Note:

Error code Remote controller: E36	LED	Green	Red	Content Discharge pipe temperature error
	Indoor	Keeps flashing	Stays OFF	
	Outdoor	Keeps flashing	1(5) time flash	

Все каталоги и инструкции здесь: <http://splitoff.ru/tehn-doc.html>

<p>1. Applicable model</p> <p>All models</p>	<p>5. Troubleshooting</p>	
<p>2. Error detection method</p> <p>For the error detection method, refer to the protective control by controlling compressor rotation speed and cooling high pressure protective control of micro computer control function for corresponding models.</p>	<p style="text-align: center;">Diagnosis</p> <pre> graph TD Q1{Are the characteristics of discharge pipe temperature thermistor normal?} Q2{Is the discharge pipe temperature error persisted during cooling operation?} Q3{Is the discharge pipe temperature control normal?} Q4{Is the temperature (measured actually) at detection of error correct?} Q1 -- NO --> C1[Replace discharge pipe temperature thermistor.] Q1 -- YES --> Q2 Q2 -- YES --> C2[Insufficient refrigerant amount: Recharge refrigerant by weighing proper amount on a scale.] Q2 -- NO --> Q3 Q3 -- NO --> C3[Control operation check *] Q3 -- YES --> Q4 Q4 -- NO --> C4[Defective outdoor control PCB -> Replace.] Q4 -- YES --> C5[Check unit side: • Isn't filter clogged? • Are adequate indoor, outdoor unit installation spaces? • Isn't there any short-circuit of air? • Isn't there any fouling, clogging on indoor heat exchanger?] </pre> <p>* For the characteristics of discharge pipe temperature, refer to E39.</p> <p>* For the contents of control, refer to the protective control by controlling compressor rotation speed and cooling high pressure protective control of micro computer control function for corresponding models.</p>	<p style="text-align: center;">Countermeasure</p>
<p>3. Condition of Error displayed</p> <p>When discharge pipe temperature anomaly is detected 2 times within 60 minutes or this anomalous state is detected 60 minutes continuously including compressor stop.</p>		<p>4. Presumable cause</p> <ul style="list-style-type: none"> • Defective outdoor control PCB • Defective discharge pipe temperature thermistor • Clogged filter • Indoor, outdoor unit installation spaces • Short-circuit of air on indoor, outdoor units • Fouling, clogging of heat exchanger

Note:

Error code Remote controller: E37	LED	Green	Red	Content Outdoor heat exchanger temperature thermistor anomaly
	Indoor	Keeps flashing	Stays OFF	
	Outdoor	Keeps flashing	1(8) time flash	

Все каталоги и инструкции здесь: <http://splitoff.ru/tehn-doc.html>

1. Applicable model
All models

2. Error detection method
Detection of anomalously low temperature (resistance) on the outdoor heat exchanger temperature thermistor

3. Condition of Error displayed

- When the temperature thermistor detects -50(-55)°C or lower for 20 seconds continuously within 2 minutes to 2 minutes 20 seconds after the compressor ON, the compressor stops. After 3-minutes delay, the compressor starts again automatically, but if this anomalous temperature is detected 3 times within 40 minutes.
- When -50(-55)°C or lower is detected for 5 seconds continuously within 20 second after compressor ON.
Note (1) Value in () are for the model SRC 40~60.

4. Presumable cause

- Defective outdoor control PCB
- Broken thermistor harness or temperature sensing section
- Disconnected wire connection (connector)

5. Troubleshooting

Diagnosis	Countermeasure
	<p>Correct connector.</p> <p>Defective outdoor heat exchanger temperature thermistor → Replace.</p> <p>Defective outdoor control PCB → Replace. (Defective outdoor heat exchanger temperature thermistor input circuit)</p>

Temperature-resistance characteristics

Temperature (°C)	Temperature thermistor resistance (kΩ)
0	15
10	10
20	6
25	5
30	4
40	3
50	2

Note:

Error code Remote controller: E38	LED	Green	Red	Content Outdoor air temperature thermistor anomaly
	Indoor	Keeps flashing	Stays OFF	
	Outdoor	Keeps flashing 1(8) time flash		

Все каталоги и инструкции здесь: <http://splitoff.ru/tehn-doc.html>

1. Applicable model All models
2. Error detection method Detection of anomalously low temperature (resistance) on outdoor air temperature thermistor
3. Condition of Error displayed <ul style="list-style-type: none"> When the temperature thermistor detects -45(-55)°C or lower for 5 seconds continuously within 2 minutes to 2 minutes 20 seconds after the compressor ON, the compressor stops. After 3-minutes delay, the compressor starts again automatically, but if this anomalous temperature is detected 3 times within 40 minutes. When -45(-55)°C or lower is detected for 5 seconds continuously within 20 second after compressor ON. Note (1) Value in () are for the Models SRC 40~60.
4. Presumable cause <ul style="list-style-type: none"> Defective outdoor control PCB Broken thermistor harness or temperature sensing section (Check molding.) Disconnected wire connection (connector)

5. Troubleshooting

Diagnosis	Countermeasure
<p>Is the outdoor air temperature thermistor connector connected properly?</p> <p>NO → Correct connector.</p> <p>YES →</p> <p>Is the characteristics of the outdoor air temperature thermistor OK?</p> <p>NO → Defective outdoor air temperature thermistor → Replace.</p> <p>YES → Defective outdoor control PCB → Replace. (Defective outdoor air temperature thermistor input circuit)</p> <p>• Models SRC40~60</p> <p>Temperature-resistance characteristics</p> <p>• Models FDC71 - 250</p> <p>Temperature-resistance characteristics</p>	

Note:

Error code Remote controller: E39	LED	Green	Red	Content Discharge pipe temperature thermistor anomaly
	Indoor	Keeps flashing	Stays OFF	
	Outdoor	Keeps flashing	1(8) time flash	

Все каталоги и инструкции здесь: <http://splitoff.ru/tehn-doc.html>

<p>All models</p> <hr/> <p>2. Error detection method</p> <p>Detection of anomalously low temperature (resistance) on the discharge pipe temperature thermistor</p> <hr/> <p>3. Condition of Error displayed</p> <p>When the temperature thermistor detects -10(-25)°C or lower for 5 seconds continuously within 10 minutes to 10 minutes 20 seconds after the compressor ON, the compressor stops. After 3-minutes delay, the compressor starts again automatically, but if this anomalous temperature is detected 3 times within 40 minutes. Note (1) Value in () are for the Models SRC40~60.</p> <hr/> <p>4. Presumable cause</p> <ul style="list-style-type: none"> • Defective outdoor control PCB • Broken thermistor harness or temperature sensing section (Check molding.) • Disconnected wire connection (connector) 	<p style="text-align: center;">Diagnosis</p> <div style="text-align: center;"> <pre> graph TD Q1{Is the discharge pipe temperature thermistor connector connected properly?} -- NO --> A1[Correct connector.] Q1 -- YES --> Q2{Are the characteristics of discharge pipe temperature thermistor OK?} Q2 -- NO --> A2[Defective discharge pipe temperature thermistor -> Replace.] Q2 -- YES --> A3[Defective outdoor control PCB -> Replace. (Defective temperature thermistor input circuit)] </pre> </div> <p>• Models SRC40~60</p> <p>(Broken wire) Temperature-resistance characteristics</p> <table border="1"> <caption>Data for Models SRC40~60 Graph</caption> <thead> <tr> <th>Temperature (°C)</th> <th>Temperature thermistor resistance (kΩ)</th> </tr> </thead> <tbody> <tr><td>0</td><td>100</td></tr> <tr><td>20</td><td>60</td></tr> <tr><td>40</td><td>35</td></tr> <tr><td>60</td><td>25</td></tr> <tr><td>80</td><td>18</td></tr> <tr><td>100</td><td>14</td></tr> <tr><td>120</td><td>11</td></tr> <tr><td>140</td><td>10</td></tr> </tbody> </table> <p>• Models FDC71 - 250</p> <p>(Broken wire) Temperature-resistance characteristics</p> <table border="1"> <caption>Data for Models FDC71 - 250 Graph</caption> <thead> <tr> <th>Temperature (°C)</th> <th>Temperature thermistor resistance (kΩ)</th> </tr> </thead> <tbody> <tr><td>0</td><td>180</td></tr> <tr><td>20</td><td>100</td></tr> <tr><td>40</td><td>50</td></tr> <tr><td>60</td><td>30</td></tr> <tr><td>80</td><td>20</td></tr> <tr><td>100</td><td>15</td></tr> <tr><td>120</td><td>12</td></tr> <tr><td>140</td><td>11</td></tr> <tr><td>160</td><td>10</td></tr> </tbody> </table>	Temperature (°C)	Temperature thermistor resistance (kΩ)	0	100	20	60	40	35	60	25	80	18	100	14	120	11	140	10	Temperature (°C)	Temperature thermistor resistance (kΩ)	0	180	20	100	40	50	60	30	80	20	100	15	120	12	140	11	160	10	<p style="text-align: center;">Countermeasure</p> <p>Correct connector.</p> <p>Defective discharge pipe temperature thermistor → Replace.</p> <p>Defective outdoor control PCB → Replace. (Defective temperature thermistor input circuit)</p>
Temperature (°C)	Temperature thermistor resistance (kΩ)																																							
0	100																																							
20	60																																							
40	35																																							
60	25																																							
80	18																																							
100	14																																							
120	11																																							
140	10																																							
Temperature (°C)	Temperature thermistor resistance (kΩ)																																							
0	180																																							
20	100																																							
40	50																																							
60	30																																							
80	20																																							
100	15																																							
120	12																																							
140	11																																							
160	10																																							

Note:

Error code Remote controller: E40	LED	Green	Red	Content High pressure error (63H1 activated) (Model FDC71 - 250)
	Indoor	Keeps flashing	Stays OFF	
	Outdoor	Keeps flashing	1 time flash	

Все каталоги и инструкции здесь: <http://splitoff.ru/tehn-doc.html>

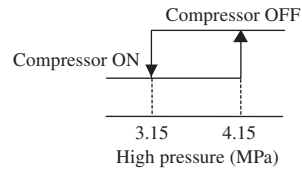
<p>1. Applicable model</p> <p>Models FDC 71 – 250</p>	<p>3. Troubleshooting</p>			
<p>2. Error detection method</p> <p>When the high pressure switch 63H1 is activated.</p> 	<table border="1"> <thead> <tr> <th>Diagnosis</th> <th>Countermeasure</th> </tr> </thead> </table>		Diagnosis	Countermeasure
Diagnosis	Countermeasure			
<p>3. Condition of Error displayed</p> <p>If 63H1 turns OFF (opened), the compressor stops. After 3-minutes delay, the compressor restarts. If this anomaly occurs 5 times within 60 minutes or continues for 60 minutes continuously.</p>	<table border="1"> <tr> <td data-bbox="486 504 1149 1986"> <p>If the power supply breaker is turned OFF and ON too quickly, E40 may be displayed. (This is normal.)</p> <p>Is the service valve fully opened?</p> <p>NO → Open service valve.</p> <p>YES</p> <p>Has 63H1 activated?</p> <p>NO → Is 63H1 connector connected properly?</p> <p>NO → Correct 63H1 connector.</p> <p>YES</p> <p>Is the electronic expansion valve connector connection OK?</p> <p>NO → Correct electronic expansion valve connector.</p> <p>YES → Defective outdoor control PCB → Replace. (Defective 63H1 input circuit)</p> <p>If any anomaly exists on the electronic expansion valve connector connection, the power supply must be reset.</p> <p>On operation of 63H1</p> <p>1. During cooling</p> <ul style="list-style-type: none"> Is the outdoor fan motor running? Isn't any short-circuit of air on the outdoor unit? Are sufficient return air/supply air space secured? <p>2. During heating</p> <ul style="list-style-type: none"> Isn't the indoor heat exchanger temperature thermistor disconnected from the thermistor casing? Isn't the filter clogged? <p>* Under the condition of overcharging refrigerant, 63H1 may activate due to delay of starting the preventive control by compressor speed control, because detected heat exchanger temperature, which conducts compressor speed control, becomes lower than normal condition due to excess sub-cooling degree.</p> </td> <td data-bbox="1149 504 1450 1986"> </td> </tr> </table>		<p>If the power supply breaker is turned OFF and ON too quickly, E40 may be displayed. (This is normal.)</p> <p>Is the service valve fully opened?</p> <p>NO → Open service valve.</p> <p>YES</p> <p>Has 63H1 activated?</p> <p>NO → Is 63H1 connector connected properly?</p> <p>NO → Correct 63H1 connector.</p> <p>YES</p> <p>Is the electronic expansion valve connector connection OK?</p> <p>NO → Correct electronic expansion valve connector.</p> <p>YES → Defective outdoor control PCB → Replace. (Defective 63H1 input circuit)</p> <p>If any anomaly exists on the electronic expansion valve connector connection, the power supply must be reset.</p> <p>On operation of 63H1</p> <p>1. During cooling</p> <ul style="list-style-type: none"> Is the outdoor fan motor running? Isn't any short-circuit of air on the outdoor unit? Are sufficient return air/supply air space secured? <p>2. During heating</p> <ul style="list-style-type: none"> Isn't the indoor heat exchanger temperature thermistor disconnected from the thermistor casing? Isn't the filter clogged? <p>* Under the condition of overcharging refrigerant, 63H1 may activate due to delay of starting the preventive control by compressor speed control, because detected heat exchanger temperature, which conducts compressor speed control, becomes lower than normal condition due to excess sub-cooling degree.</p>	
<p>If the power supply breaker is turned OFF and ON too quickly, E40 may be displayed. (This is normal.)</p> <p>Is the service valve fully opened?</p> <p>NO → Open service valve.</p> <p>YES</p> <p>Has 63H1 activated?</p> <p>NO → Is 63H1 connector connected properly?</p> <p>NO → Correct 63H1 connector.</p> <p>YES</p> <p>Is the electronic expansion valve connector connection OK?</p> <p>NO → Correct electronic expansion valve connector.</p> <p>YES → Defective outdoor control PCB → Replace. (Defective 63H1 input circuit)</p> <p>If any anomaly exists on the electronic expansion valve connector connection, the power supply must be reset.</p> <p>On operation of 63H1</p> <p>1. During cooling</p> <ul style="list-style-type: none"> Is the outdoor fan motor running? Isn't any short-circuit of air on the outdoor unit? Are sufficient return air/supply air space secured? <p>2. During heating</p> <ul style="list-style-type: none"> Isn't the indoor heat exchanger temperature thermistor disconnected from the thermistor casing? Isn't the filter clogged? <p>* Under the condition of overcharging refrigerant, 63H1 may activate due to delay of starting the preventive control by compressor speed control, because detected heat exchanger temperature, which conducts compressor speed control, becomes lower than normal condition due to excess sub-cooling degree.</p>				
<p>4. Presumable cause</p> <ul style="list-style-type: none"> Short circuit of air flow, disturbance of air flow and clogging filter at outdoor heat exchanger/Breakdown of fan motor Defective outdoor control PCB Defective 63H1 connector Defective electronic expansion valve connector Closed service valve Mixing of non-condensing gas (nitrogen, etc.) 				

Note: In the protective control range for compressor startup (initial startup after power ON), even if 63H1 is activated only once (63H1 turns OFF), immediately the error is displayed.

Error code Remote controller: E41	LED	Green	Red	Content Power transistor overheat (Models FDC71, 100VN, 125VN, 140VN, 200, 250)
	Indoor control PCB	Keeps flashing	Stays OFF	
	Outdoor control PCB	Keeps flashing	1 time flash	
	Outdoor inverter	Yellow LED or Red LED	Green LED	

Все каталоги и инструкции здесь: <http://splitoff.ru/tehn-doc.html>

1.Applicable model
Model FDC200, 250

2.Error detection method
Anomalous rise of the internal power transistor temperature

3.Condition of Error displayed
When anomalous rise of the internal power transistor temperature is detected 5 times within 1 hour.

4.Presumable cause
<ul style="list-style-type: none"> • Defective inverter PCB • Defective outdoor fan motor • Improperly fixed power transistor radiator fin • Delective power transistor temperature thermistor • Inadequate installation space

5.Troubleshooting

Diagnosis	Countermeasure
	<p>OK</p> <p>Replace power transistor.</p> <p>OK</p> <p>Fix properly.</p> <p>OK</p>
<p>* Characteristics of power transistor temperature thermistor</p> <p style="text-align: center;">Temperature-resistance characteristics</p>	

Note:

Error code Remote controller: E42	LED	Green	Red	Content
	Indoor control PCB	Keeps flashing	Stays OFF	
	Outdoor control PCB	Keeps flashing	1 time flash	
	Outdoor inverter	Yellow LED or Red LED	Green LED	

Current cut (1/2)

Все каталоги и инструкции здесь: <http://splitoff.ru/tehn-doc.html>

<p>1. Applicable model</p> <p>All models</p>	<p>5. Troubleshooting</p>	
<p>2. Error detection method</p> <p>In order to prevent from overcurrent of inverter, if the current exceeds the specifications, it makes the compressor stopping.</p>	<p style="text-align: center;">Diagnosis</p> <pre> graph TD Q1{Is the Power supply voltage OK?} -- NO --> C1[Check power supply.] Q1 -- YES --> Q2{Are the service valves opened?} Q2 -- NO --> C2[Open the valves.] Q2 -- YES --> Q3{Is the high pressure during operation OK?} Q3 -- NO --> C3[Check refrigerant amount and refrigerant circuit *In case of transitional increase of high pressure and/or test run, several times restarting may recover it, because liquid refrigerant (migrated) in the compressor is discharged from the compressor.] Q3 -- YES --> Q4{Is the checked result of insulation resistance and coil resistance (1) of compressor motor OK?} Q4 -- NO --> C4[Replace compressor.] Q4 -- YES --> C5[Continues to next page.] </pre> <p>(1) 0.999Ω or more at 20°C (Model FDC71) 0.293Ω or more at 20°C (Models FDC100~140VN) 1.172Ω or more at 20°C (Models FDC100~140VS) 0.334Ω or more at 20°C (Models FDC200, 250) 0.953Ω or more at 20°C (Models SRC40~60)</p>	<p style="text-align: center;">Countermeasure</p>
<p>3. Condition of Error displayed</p> <ul style="list-style-type: none"> • If the output current of inverter exceeds the specifications, it makes the compressor stopping. • After 3-minute delay, the compressor restarts, but if this anomaly occurs 4 times within 30 minute after the initial detection. (Model FDC71 – 250 only) 		
<p>4. Presumable cause</p> <ul style="list-style-type: none"> • The valves closed • Faulty power supply • Insufficient refrigerant amount • Faulty compressor • Faulty power transistor module 		

Note:

Error code Remote controller: E42	LED	Green	Red	Content
	Indoor	Keeps flashing	Stays OFF	
	Outdoor control PCB	Keeps flashing	1 time flash	
	Outdoor inverter	Yellow LED or Red LED	Green LED	

Current cut (2/2)

Все каталоги и инструкции здесь: <http://splitoff.ru/tehn-doc.html>

<p>1. Applicable model</p> <p>All models</p>	<p>5. Troubleshooting</p>	
<p>2. Error detection method</p> <p>In order to prevent from overcurrent of inverter, if the current exceeds the specifications, it makes the compressor stopping.</p>	<p style="text-align: center;">Diagnosis</p> <p style="text-align: center;">Countermeasure</p> <div style="text-align: center;"> <p>Continue from previous page</p> </div>	
<p>3. Condition of Error displayed</p> <ul style="list-style-type: none"> • If the output current of inverter exceeds the specifications, it makes the compressor stopping. • After 3-minute delay, the compressor restarts, but if this anomaly occurs 4 times within 30 minute after the initial detection. (Model FDC71 – 250 only) 		
<p>4. Presumable cause</p> <ul style="list-style-type: none"> • Defective outdoor control PCB • Defective inverter PCB • Faulty power supply • Insufficient refrigerant amount • Faulty compressor • Faulty power transistor module 		

Note:

Error code Remote controller: E45	LED	Green	Red	Content Inverter communication error (Model FDC71 - 250)
	Indoor	Keeps flashing	Stays OFF	
	Outdoor	Keeps flashing	1 time flash	

Все каталоги и инструкции здесь: <http://splitoff.ru/tehn-doc.html>

<p>1. Applicable model</p> <p>Model FDC 71 – 250</p>	<p>5. Troubleshooting</p>	
<p>2. Error detection method</p>	<p style="text-align: center;">Diagnosis</p>	<p style="text-align: center;">Countermeasure</p>
<p>3. Condition of Error displayed</p> <p>When communication is not established between the inverter PCB and the outdoor control PCB.</p>		
<p>4. Presumable cause</p> <ul style="list-style-type: none"> • Defective inverter PCB • Defective connector between the outdoor control PCB and inverter PCB • Defective outdoor control PCB 		

Note:

Error code Remote controller: E47	LED	Green	Red	Content Inverter over-current error (Model SRC40 – 60)
	Indoor	Keeps flashing	Stays OFF	
	Outdoor	–	2 times flash	

Все каталоги и инструкции здесь: <http://splitoff.ru/tehn-doc.html>

1. Applicable model	2. Troubleshooting	
Model SRC40 – 60	Diagnosis	Countermeasure
2. Error detection method	<pre> graph TD A{Check soldered surfaces on the control PCB for foreign matter like dust, fouling, etc.} -- NO --> B[Remove foreign matter like dust, fouling, etc.] A -- YES --> C{Isn't F2 fuse (250V, 20A) blown?} C -- NO --> D[Replace fuse.] C -- YES --> E[Defective outdoor control PCB -> Replace.] </pre>	
3. Condition of Error displayed		
Same as above		
4. Presumable cause		
<ul style="list-style-type: none"> • Defective outdoor control PCB • Dust on control PCB • Blown F2 fuse 		

Note:

Error code Remote controller: E47	LED	Green	Red	Content Inverter PCBA/F module anomaly (Model FDC71VN)
	Indoor	Keeps flashing	Stays off	
	Outdoor control PCB	Keeps flashing	1 time flash	
	Outdoor Inverter PCB	Yellow LED or Red LED 7 times flashing	Green LED Keeps flashing	

Все каталоги и инструкции здесь: <http://splitoff.ru/tehn-doc.html>

<p>1. Applicable model</p> <p>Model FDC71</p>	<p>5. Troubleshooting</p> <table border="1" style="width: 100%;"> <thead> <tr> <th style="width: 50%;">Diagnosis</th> <th style="width: 50%;">Countermeasure</th> </tr> </thead> <tbody> <tr> <td style="text-align: center;"> <pre> graph TD Q1{Is the Power supply voltage OK?} -- NO --> C1[Check power supply.] Q1 -- YES --> Q2{Is the checked results of insulation resistance and coil resistance (1) of compressor motor OK? (1) 0.999Ω or more at 20°C (FDC71)} Q2 -- NO --> C2[Replace compressor.] Q2 -- YES --> C3[Defective outdoor Inverter PCB -> Replace.] </pre> </td> <td></td> </tr> </tbody> </table>	Diagnosis	Countermeasure	<pre> graph TD Q1{Is the Power supply voltage OK?} -- NO --> C1[Check power supply.] Q1 -- YES --> Q2{Is the checked results of insulation resistance and coil resistance (1) of compressor motor OK? (1) 0.999Ω or more at 20°C (FDC71)} Q2 -- NO --> C2[Replace compressor.] Q2 -- YES --> C3[Defective outdoor Inverter PCB -> Replace.] </pre>	
Diagnosis	Countermeasure				
<pre> graph TD Q1{Is the Power supply voltage OK?} -- NO --> C1[Check power supply.] Q1 -- YES --> Q2{Is the checked results of insulation resistance and coil resistance (1) of compressor motor OK? (1) 0.999Ω or more at 20°C (FDC71)} Q2 -- NO --> C2[Replace compressor.] Q2 -- YES --> C3[Defective outdoor Inverter PCB -> Replace.] </pre>					
<p>2. Error detection method</p> <p>In order to prevent from overcurrent of A/F, if the current exceeds the specifications, it makes the compressor stopping.</p>					
<p>3. Condition of error displayed</p> <ul style="list-style-type: none"> • If the output current of A/F exceeds the specifications, it makes the compressor stopping. 					
<p>4. Presumable cause</p> <ul style="list-style-type: none"> • Defective inverter PCB 					

Note:

Error code Remote controller: E48	LED	Green	Red	Content Outdoor fan motor anomaly (Model SRC40 - 60)
	Indoor	Keeps flashing	Stays OFF	
	Outdoor	—	Keeps flashing	

Все каталоги и инструкции здесь: <http://splitoff.ru/tehn-doc.html>

1. Applicable model	2. Troubleshooting	
Model SRC 40 – 60	<div style="text-align: center;"> <p>Diagnosis</p> </div>	<p style="text-align: center;">Countermeasure</p>
2. Error detection method		
Detected by rotation speed of outdoor fan motor		
3. Condition of Error displayed		
4. Presumable cause		

Note: When E48 error occurs, in almost cases F3 fuse (1A) on the outdoor control PCB is blown. There are a lot of cases that fuse is blown and E48 occurs due to defective fan motor. And even though only the outdoor control PCB (or fuse) is replaced, another trouble (*1) could occur. Therefore when fuse is blown, check whether the fan motor is OK or not. After confirming the fan motor normal, check by power ON. (Don't power ON without confirming the fan motor normal.)
 *1 The error which does not seem to relate E48 may occur like as "WAIT", Stay OFF of LED on outdoor control PCB, inverter communication error (E45) and etc.

Error code Remote controller: E48	LED	Green	Red	Content Outdoor fan motor anomaly (Model FDC71 - 250)
	Indoor	Keeps flashing	Stays OFF	
	Outdoor	Keeps flashing	1 time flash	

Все каталоги и инструкции здесь: <http://splitoff.ru/tehn-doc.html>

1. Applicable model	2. Troubleshooting	
Model FDC 71 – 250	Diagnosis	Countermeasure
2. Error detection method	<pre> graph TD Q1{Does any foreign material intervene in rotational area of fan propeller?} -- YES --> C1[Remove foreign material.] Q1 -- NO --> Q2{Does the fan rotate smoothly when turned by hand?} Q2 -- NO --> C2["Replace fan motor. If resistance between ① (Vm):red -④(GND):blue is detected 1kΩ or lower, it is faulty."] Q2 -- YES --> Q3{Is DC280V detected between (CNFAN ① (red)-④ (blue)) of fan motor connector?} Q3 -- YES --> R1[Power supply reset] Q3 -- NO --> Q4{Is F2 fuse blown?} Q4 -- YES --> C3[Replace faulty fan motor and control PCB.] Q4 -- NO --> C4[Check power supply voltage.] R1 --> Q5{Is normal state restored?} Q5 -- YES --> C5[Malfunction by temporary noise] Q5 -- NO --> C6[Replace fan motor (If anomaly persists after replacing fan motor, replace control PCB.)] </pre>	
3. Condition of Error displayed		
4. Presumable cause		
<ul style="list-style-type: none"> • Defective outdoor control PCB • Foreign material at rotational area of fan propeller • Defective fan motor • Dust on outdoor control PCB • Blow fuse • External noise, surge 		

Note: When E48 error occurs, in almost cases F2 fuse (4A) [Model 71:F3 fuse (2A)]on the outdoor control PCB is blown. There are a lot of cases that fuse is blown and E48 occurs due to defective fan motor. And even though only the outdoor control PCB (or fuse) is replaced,, another trouble (*1) could occur. Therefore when fuse is blown, check whether the fan motor is OK or not. After confirming the fan motor normal, check by power ON. (Don't power ON without confirming the fan motor normal.)
 *1 The error which does not seem to relate E48 may occur like as "WAIT", Stay OFF of LED on outdoor control PCB, inverter communication error (E45) and etc.

Error code Remote controller: E49	LED	Green	Red	Content Low pressure error or low pressure sensor anomaly (1/2) (Model FDC71 - 250)
	Indoor	Keeps flashing	Stays OFF	
	Outdoor	Keeps flashing	1 time flash	

Все каталоги и инструкции здесь: <http://splitoff.ru/tehn-doc.html>

1. Applicable model Model FDC 71 – 250
2. Error detection method Detected by low pressure drop and suction superheat
3. Condition of Error displayed ① When the low pressure sensor detects 0.079MPa or lower for 15 seconds continuously, compressor stops and it restarts automatically after 3-minutes delay. And if this anomaly occurs 3 times within 60 minutes, ② 10 minutes after the compressor starts, if the low pressure sensor detects 0.15MPa or lower for 60 minutes continuously and compressor suction superheat is detected 30degC or higher for 60 minutes continuously. And if this anomaly occurs 3 times within 60 minutes, ③ If low pressure sensor detects 0.079MPa or lower for 5 minutes continuously (including the compressor stop status),
4. Presumable cause <ul style="list-style-type: none"> • Defective outdoor control PCB • Defective low pressure sensor connector • Defective low pressure sensor • Defective suction pipe temperature thermistor connector • Defective suction pipe temperature thermistor

5. Troubleshooting	
Diagnosis	Countermeasure

Note: * Connect the gauge manifold to the service valve check joint during cooling, or connect it to the check joint at internal piping of outdoor unit during heating.

Error code Remote controller: E49	LED	Green	Red	Content Low pressure error or low pressure sensor anomaly (2/2) (Model FDC71 - 250)
	Indoor	Keeps flashing	Stays OFF	
	Outdoor	Keeps flashing	1 time flash	

Все каталоги и инструкции здесь: <http://splitoff.ru/tehn-doc.html>

1. Applicable model Model FDC 71 – 250	2. Troubleshooting	
2. Error detection method	Diagnosis	
3. Condition of Error displayed	Countermeasure	
4. Presumable cause	<p>Continued from previous page.</p> <pre> graph TD Start[Continued from previous page.] --> D1{Is the service valve fully opened?} D1 -- NO --> C1[Open fully.] D1 -- YES --> D2{Are the connections of low pressure sensor and suction pipe temperature thermistor connector OK?} D2 -- NO --> C2[Correct.] D2 -- YES --> D3{Are the characteristics of low pressure sensor, suction pipe temperature thermistor OK?} D3 -- NO --> C3[Defective low pressure sensor, suction pipe temperature thermistor → Replace.] D3 -- YES --> D4{Is the low pressure normal during operation?} D4 -- NO --> C4[Charge refrigerant.] D4 -- YES --> C5[Defective outdoor control PCB → Replace. (Defective low pressure sensor, suction pipe temperature thermistor circuits)] </pre>	

Note:

Error code Remote controller: E51	LED	Green	Red	Content Power transistor anomaly (Models SRC40 - 60)
	Indoor	Keeps flashing	Stays OFF	
	Outdoor	—	1 time flash	

Все каталоги и инструкции здесь: <http://splitoff.ru/tehn-doc.html>

<p>1. Applicable model</p> <p>Model SRC40 – 60</p>	<p>5. Troubleshooting</p>	
<p>2. Error detection method</p> <p>Power transistor primary current</p>	<p style="text-align: center;">Diagnosis</p> <pre> graph TD D1{Is the power supply normal?} -- NO --> C1[Restore normal condition.] D1 -- YES --> D2{Is voltage within the specified range?} D2 -- NO --> C2[Restore normal condition.] D2 -- YES --> D3{Check soldered surfaces on the outdoor control PCB for foreign matter like dust, fouling, etc.} D3 -- NO --> C3[Remove foreign matter like dust, fouling, etc.] D3 -- YES --> C4[Defective outdoor control PCB -> Replace.] </pre>	<p style="text-align: center;">Countermeasure</p>
<p>3. Condition of Error displayed</p> <p>If the power transistor primary current exceeds the setting value for 3 seconds, the compressor stops.</p>		
<p>4. Presumable cause</p> <ul style="list-style-type: none"> • Faulty outdoor control PCB • Dust on control PCB • Anomalous power supply 		

Note:

Error code Remote controller: E51	LED	Green	Red	Content Inverter and fan motor anomaly (Model FDC71 - 250)
	Indoor control PCB	Keeps flashing	Stays OFF	
	Outdoor control PCB	Keeps flashing	1 time flash	
	Outdoor inverter	Yellow LED or Red LED	Green LED	

Все каталоги и инструкции здесь: <http://splitoff.ru/tehn-doc.html>

<p>1. Applicable model</p> <p>Model FDC71 – 250</p>	<p>5. Troubleshooting</p>	
<p>2. Error detection method</p> <p>When power transistor anomaly is detected for 15 minutes continuously</p>	<p style="text-align: center;">Diagnosis</p> <pre> graph TD D1{Is DC15V detected between the connector CN14 ②-③ (CN12 ②-③) on the inverter PCB?} D2{Is DC15V detected between the harnesses at the control PCB side after disconnecting the connector (CN14 or 2)?} D3{Is DC15V detected on the fan motor connector?} D1 -- YES --> C1[Defective inverter PCB -> Replace.] D1 -- NO --> D2 D2 -- YES --> C2[Broken harness wire] D2 -- NO --> D3 D3 -- YES --> C3[Replace fan motor.] D3 -- NO --> C4[Defective outdoor control PCB -> Replace.] Note[• Model FDC200, 250 Replace immediately the inverter PCB and the power transistor madule.] </pre>	<p style="text-align: center;">Countermeasure</p>
<p>3. Condition of Error displayed</p> <p>Same as above</p>		
<p>4. Presumable cause</p> <ul style="list-style-type: none"> • Defective outdoor fan motor • Defective inverter PCB • Defective outdoor control PCB 		

Note:

Error code Remote controller: E53	LED	Green	Red	Content Suction pipe temperature thermistor anomaly (Model FDC71 - 250)
	Indoor	Keeps flashing	Stays OFF	
	Outdoor	Keeps flashing	1 time flash	

Все каталоги и инструкции здесь: <http://splitoff.ru/tehn-doc.html>

<p>1. Applicable model</p> <p>Model FDC 71 – 250</p>	<p>2. Troubleshooting</p>																	
<p>2. Error detection method</p> <p>When the suction pipe temperature thermistor detects anomalously low temperature</p>	<p style="text-align: center;">Diagnosis</p> <pre> graph TD A{Is the connection of suction pipe temperature thermistor connector OK?} -- NO --> B[Correct connection of suction pipe temperature thermistor connector.] A -- YES --> C{Are the characteristics of suction pipe temperature thermistor OK?} C -- NO --> D[Defective suction pipe temperature thermistor -> Replace.] C -- YES --> E[Defective outdoor control PCB -> Replace. (Defective suction pipe temperature thermistor input circuit)] </pre>	<p style="text-align: center;">Countermeasure</p>																
<p>3. Condition of Error displayed</p> <p>If the temperature thermistor detects -50°C or lower for 5 seconds continuously within 10 minutes to 10 minutes 20 seconds after compressor ON, the compressor stops. When the compressor is restarted automatically after 3-minutes delay, if this anomaly occurs 3 times within 40 minutes.</p>																		
<p>4. Presumable cause</p> <ul style="list-style-type: none"> • Defective suction pipe temperature thermistor connection • Defective suction pipe temperature thermistor • Defective outdoor control PCB 	<p style="text-align: center;">Temperature-resistance characteristics</p> <table border="1"> <caption>Temperature-resistance characteristics data points (approximate)</caption> <thead> <tr> <th>Temperature (°C)</th> <th>Resistance (kΩ)</th> </tr> </thead> <tbody> <tr> <td>0</td> <td>15</td> </tr> <tr> <td>10</td> <td>10</td> </tr> <tr> <td>20</td> <td>7</td> </tr> <tr> <td>25</td> <td>5</td> </tr> <tr> <td>30</td> <td>4</td> </tr> <tr> <td>40</td> <td>3</td> </tr> <tr> <td>50</td> <td>2</td> </tr> </tbody> </table>		Temperature (°C)	Resistance (kΩ)	0	15	10	10	20	7	25	5	30	4	40	3	50	2
Temperature (°C)	Resistance (kΩ)																	
0	15																	
10	10																	
20	7																	
25	5																	
30	4																	
40	3																	
50	2																	

Note:

Error code Remote controller: E54	LED	Green	Red	Content Low pressure sensor anomaly (Models FDC71~250)
	Indoor	Keeps flashing	Stays OFF	
	Outdoor	Keeps flashing	1 time flash	

Все каталоги и инструкции здесь: <http://splitoff.ru/tehn-doc.html>

<p>1. Applicable model</p> <p>Models FDC 71~250</p>	<p>2. Troubleshooting</p>											
<p>2. Error detection method</p> <p>When anomalous voltage (pressure) is detected</p>	<table border="1"> <thead> <tr> <th data-bbox="517 434 1150 510">Diagnosis</th> <th data-bbox="1150 434 1450 510">Countermeasure</th> </tr> </thead> <tbody> <tr> <td data-bbox="517 510 1150 719"> <pre> graph TD Q1{Are the connection of low pressure sensor connectors (at sensor side and PCB side) OK?} Q2{Are the pressure (actual measurement) matched with the value indicated on the remote controller?} P1[Replace the low pressure sensor.] Q3{Is normal condition restored?} Q1 -- NO --> C1[Correct low pressure sensor connector connection.] Q1 -- YES --> Q2 Q2 -- YES --> C2[Is refrigerant amount charged properly? Is there any anomaly on the refrigeration circuit?] Q2 -- NO --> P1 P1 --> Q3 Q3 -- NO --> C3[Defective outdoor control PCB -> Replace. (Defective low pressure sensor input circuit)] Q3 -- YES --> C4[OK] </pre> </td> <td data-bbox="1150 510 1450 1982"></td> </tr> <tr> <td data-bbox="145 1211 488 1554"> <p>3. Condition of Error displayed</p> <p>If the pressure sensor detects 0V or lower and 3.49V or higher for 5 seconds continuously within 2 minutes to 2 minutes 20 seconds after compressor ON, the compressor stops. When the compressor is restarted automatically after 3-minuts delay, if this anomaly occurs 3 times within 40 minutes</p> </td> <td colspan="2"></td> </tr> <tr> <td data-bbox="145 1576 488 1982"> <p>4. Presumable cause</p> <ul style="list-style-type: none"> • Defective low pressure sensor connection • Defective low pressure sensor • Defective outdoor control PCB • Improper amount of refrigerant • Anomalous refrigeration circuit </td> <td colspan="2"></td> </tr> </tbody> </table>		Diagnosis	Countermeasure	<pre> graph TD Q1{Are the connection of low pressure sensor connectors (at sensor side and PCB side) OK?} Q2{Are the pressure (actual measurement) matched with the value indicated on the remote controller?} P1[Replace the low pressure sensor.] Q3{Is normal condition restored?} Q1 -- NO --> C1[Correct low pressure sensor connector connection.] Q1 -- YES --> Q2 Q2 -- YES --> C2[Is refrigerant amount charged properly? Is there any anomaly on the refrigeration circuit?] Q2 -- NO --> P1 P1 --> Q3 Q3 -- NO --> C3[Defective outdoor control PCB -> Replace. (Defective low pressure sensor input circuit)] Q3 -- YES --> C4[OK] </pre>		<p>3. Condition of Error displayed</p> <p>If the pressure sensor detects 0V or lower and 3.49V or higher for 5 seconds continuously within 2 minutes to 2 minutes 20 seconds after compressor ON, the compressor stops. When the compressor is restarted automatically after 3-minuts delay, if this anomaly occurs 3 times within 40 minutes</p>			<p>4. Presumable cause</p> <ul style="list-style-type: none"> • Defective low pressure sensor connection • Defective low pressure sensor • Defective outdoor control PCB • Improper amount of refrigerant • Anomalous refrigeration circuit 		
Diagnosis	Countermeasure											
<pre> graph TD Q1{Are the connection of low pressure sensor connectors (at sensor side and PCB side) OK?} Q2{Are the pressure (actual measurement) matched with the value indicated on the remote controller?} P1[Replace the low pressure sensor.] Q3{Is normal condition restored?} Q1 -- NO --> C1[Correct low pressure sensor connector connection.] Q1 -- YES --> Q2 Q2 -- YES --> C2[Is refrigerant amount charged properly? Is there any anomaly on the refrigeration circuit?] Q2 -- NO --> P1 P1 --> Q3 Q3 -- NO --> C3[Defective outdoor control PCB -> Replace. (Defective low pressure sensor input circuit)] Q3 -- YES --> C4[OK] </pre>												
<p>3. Condition of Error displayed</p> <p>If the pressure sensor detects 0V or lower and 3.49V or higher for 5 seconds continuously within 2 minutes to 2 minutes 20 seconds after compressor ON, the compressor stops. When the compressor is restarted automatically after 3-minuts delay, if this anomaly occurs 3 times within 40 minutes</p>												
<p>4. Presumable cause</p> <ul style="list-style-type: none"> • Defective low pressure sensor connection • Defective low pressure sensor • Defective outdoor control PCB • Improper amount of refrigerant • Anomalous refrigeration circuit 												
<p>Note:</p>												

Error code Remote controller: E55	LED	Green	Red	Content Underneath temperature thermistor anomaly (Models FDC200, 250)
	Indoor	Keeps flashing	Stays OFF	
	Outdoor	Keeps flashing	1 time flash	

Все каталоги и инструкции здесь: <http://splitoff.ru/tehn-doc.html>

1. Applicable model	2. Troubleshooting																	
Models FDC200, 250	Diagnosis	Countermeasure																
2. Error detection method	<pre> graph TD A{Is the connection of underneath temperature thermistor connector OK?} -- NO --> B[Correct connection of underneath temperature thermistor connector.] A -- YES --> C{Are the characteristics of underneath temperature thermistor OK?} C -- NO --> D[Defective underneath temperature thermistor -> Replace.] C -- YES --> E[Replace outdoor control PCB. (Defective underneath temperature thermistor input circuit)] </pre>																	
When anomalous low temperature (resistance) is detected by the underneath temperature thermistor	<p>Temperature-resistance characteristics</p> <table border="1"> <caption>Temperature-resistance characteristics</caption> <thead> <tr> <th>Temperature (°C)</th> <th>Temperature thermistor resistance (kΩ)</th> </tr> </thead> <tbody> <tr> <td>0</td> <td>~15</td> </tr> <tr> <td>10</td> <td>~10</td> </tr> <tr> <td>20</td> <td>~6</td> </tr> <tr> <td>25</td> <td>5</td> </tr> <tr> <td>30</td> <td>~4</td> </tr> <tr> <td>40</td> <td>~3</td> </tr> <tr> <td>50</td> <td>~2</td> </tr> </tbody> </table>		Temperature (°C)	Temperature thermistor resistance (kΩ)	0	~15	10	~10	20	~6	25	5	30	~4	40	~3	50	~2
Temperature (°C)	Temperature thermistor resistance (kΩ)																	
0	~15																	
10	~10																	
20	~6																	
25	5																	
30	~4																	
40	~3																	
50	~2																	
3. Condition of Error displayed	<p>If the temperature thermistor detects -50°C or lower for 5 seconds continuously within 10 minutes to 10 minutes 20 seconds after compressor ON, the compressor stops. When the compressor is restarted automatically after 3-minutes delay, if this anomaly occurs 3 times within 40 minute.</p>																	
4. Presumable cause	<ul style="list-style-type: none"> • Defective underneath temperature thermistor connection • Defective underneath temperature thermistor • Defective outdoor control PCB 																	

Note:

Error code Remote controller: E57	LED	Green	Red	Content Insufficient refrigerant amount or detection of service valve closure (Models SRC40~60)
	Indoor	Keeps flashing	Stays OFF	
	Outdoor	—	2 times flash	

Все каталоги и инструкции здесь: <http://splitoff.ru/tehn-doc.html>

<p>1. Applicable model</p> <p>Models SRC40~60</p>	<p>5. Troubleshooting</p>													
<p>2. Error detection method</p> <ul style="list-style-type: none"> Judge insufficient refrigerant amount by detecting the temperature difference between indoor heat exchanger (ThI-R) and indoor return air (ThI-A). 	<table border="1"> <thead> <tr> <th>Diagnosis</th> <th>Countermeasure</th> </tr> </thead> <tbody> <tr> <td> <p>Is the service valve fully opened?</p> <p>NO →</p> <p>YES ↓</p> </td> <td>Open fully.</td> </tr> <tr> <td> <p>Are the connections of indoor heat exchanger and/or return air temperature thermistor connectors OK?</p> <p>NO →</p> <p>YES ↓</p> </td> <td>Correct indoor heat exchanger, return air temperature thermistor connector connections.</td> </tr> <tr> <td> <p>Are the characteristics of indoor heat exchanger and/or return air temperature thermistor OK?</p> <p>NO →</p> <p>YES ↓</p> </td> <td>Defective indoor heat exchanger, return air temperature thermistor → Replace.</td> </tr> <tr> <td> <p>Is the low pressure during operation normal?</p> <p>NO →</p> <p>YES →</p> </td> <td>Charge refrigerant.</td> </tr> <tr> <td></td> <td>Defective indoor control PCB → Replace. (Defective indoor heat exchanger, return air temperature thermistor input circuits)</td> </tr> </tbody> </table>		Diagnosis	Countermeasure	<p>Is the service valve fully opened?</p> <p>NO →</p> <p>YES ↓</p>	Open fully.	<p>Are the connections of indoor heat exchanger and/or return air temperature thermistor connectors OK?</p> <p>NO →</p> <p>YES ↓</p>	Correct indoor heat exchanger, return air temperature thermistor connector connections.	<p>Are the characteristics of indoor heat exchanger and/or return air temperature thermistor OK?</p> <p>NO →</p> <p>YES ↓</p>	Defective indoor heat exchanger, return air temperature thermistor → Replace.	<p>Is the low pressure during operation normal?</p> <p>NO →</p> <p>YES →</p>	Charge refrigerant.		Defective indoor control PCB → Replace. (Defective indoor heat exchanger, return air temperature thermistor input circuits)
Diagnosis	Countermeasure													
<p>Is the service valve fully opened?</p> <p>NO →</p> <p>YES ↓</p>	Open fully.													
<p>Are the connections of indoor heat exchanger and/or return air temperature thermistor connectors OK?</p> <p>NO →</p> <p>YES ↓</p>	Correct indoor heat exchanger, return air temperature thermistor connector connections.													
<p>Are the characteristics of indoor heat exchanger and/or return air temperature thermistor OK?</p> <p>NO →</p> <p>YES ↓</p>	Defective indoor heat exchanger, return air temperature thermistor → Replace.													
<p>Is the low pressure during operation normal?</p> <p>NO →</p> <p>YES →</p>	Charge refrigerant.													
	Defective indoor control PCB → Replace. (Defective indoor heat exchanger, return air temperature thermistor input circuits)													
<p>3. Condition of Error displayed</p> <p>When the insufficient refrigerant amount is detected 3 times within 60 minutes.</p>	<p>Indoor heat exchanger, return air temperature thermistor Temperature-resistance characteristics</p> <p>(Broken wire)</p> <p>(Shot circuit)</p>													
<p>4. Presumable cause</p> <ul style="list-style-type: none"> Defective indoor heat exchanger temperature thermistor Defective indoor return air temperature thermistor Defective indoor control PCB Insufficient refrigerant amount 														

Note: When the compressor speed is 40 rps or under at 5 minutes (or 9 minutes during heating) after the start of compressor or the completion of defrosting, the low refrigerant protection control judges, by detecting the difference between the indoor heat exchanger temperature (ThI-R) and the indoor return air temperature (ThI-A), that it is in the state of gas low, and stops the compressor.
 Cooling: Indoor return air temperature (ThI-A) – Indoor heat exchanger temperature (ThI-R) \geq 4 deg
 Heating: Indoor heat exchanger temperature (ThI-R) – Indoor return air temperature (ThI-A) \leq 4 deg

Error code Remote controller: E57	LED	Green	Red	Content Insufficient refrigerant amount or detection of service valve closure (Models FDC71~250)
	Indoor	Keeps flashing	Stays OFF	
	Outdoor	Keeps flashing	1 time flash	

Все каталоги и инструкции здесь: <http://splitoff.ru/tehn-doc.html>

1. Applicable model
Models FDC71~250

2. Error detection method

- Judge insufficient refrigerant amount by detecting the temperature difference between indoor heat exchanger (ThI-R) and indoor return air (ThI-A).
- It detects at initial startup in cooling or dehumidifying mode after power ON. (In case of model 71 it cannot detect)

3. Condition of Error displayed

When the insufficient refrigerant amount is detected 3 times within 30 minutes. (In case of Models 100 ~ 250 it makes anomalous stop at initial detection)

4. Presumable cause

- Defective indoor heat exchanger temperature thermistor
- Defective indoor return air temperature thermistor
- Defective indoor control PCB
- Insufficient refrigerant amount

5. Troubleshooting

Diagnosis	Countermeasure
<p>Is the service valve fully opened?</p> <p>NO →</p> <p>YES ↓</p> <p>Are the connections of indoor heat exchanger and/or return air temperature thermistor connectors OK?</p> <p>NO →</p> <p>YES ↓</p> <p>Are the characteristics of indoor heat exchanger and/or return air temperature thermistor OK?</p> <p>NO →</p> <p>YES ↓</p> <p>Is the low pressure during operation normal?</p> <p>NO →</p> <p>YES →</p>	<p>Open fully.</p> <p>Correct indoor heat exchanger, return air temperature thermistor connector connections.</p> <p>Defective indoor heat exchanger, return air temperature thermistor → Replace.</p> <p>Charge refrigerant.</p> <p>Defective indoor control PCB → Replace. (Defective indoor heat exchanger, return air temperature thermistor input circuits)</p>

Indoor heat exchanger, return air temperature thermistor Temperature-resistance characteristics

(Broken wire)

(Shot circuit)

Note: Insufficient refrigerant amount preventive control makes compressor stopped, if it judges insufficient refrigerant amount by detecting the temperature difference between indoor heat exchanger (ThI-R) and return air temperature (ThI-A) for 1 minute after compressor ON in cooling or dehumidifying mode and for 9 minutes after compressor ON in heating mode. [in cooling mode: (ThI-A)-(ThI-R)>4degC, in heating mode: (ThI-R)-(ThI-A)<4degC]

Error code Remote controller: E58	LED	Green	Red	Content Current safe stop (Models SRC40~60)
	Indoor	Keeps flashing	Stays OFF	
	Outdoor	—	3 times flash	

Все каталоги и инструкции здесь: <http://splitoff.ru/tehn-doc.html>

<p>1. Applicable model</p> <p>Models SRC40~60</p>	<p>5. Troubleshooting</p>	
<p>2. Error detection method</p> <p>When the current safe control has operated at the compressor speed of 30 rps or under:</p>	<p>Diagnosis</p>	<p>Countermeasure</p>
<p>3. Condition of Error displayed</p> <p>Same as above</p>	<pre> graph TD D1{Is the refrigerant amount normal?} -- NO --> C1[Adjust the refrigerant amount properly.] D1 -- YES --> D2{Is outdoor ventilation condition good?} D2 -- NO --> C2[Secure space for inlet and outlet.] D2 -- YES --> D3{Inspect compressor} D3 -- NO --> C3[Replace compressor.] D3 -- YES --> D4{Inspect outdoor air temp. sensor} D4 -- NO --> C4[Replace sensor.] D4 -- YES --> C5[Defective outdoor control PCB → Replace. (Defective outdoor air temp. sensor input circuit)] </pre>	
<p>4. Presumable cause</p> <ul style="list-style-type: none"> • Excessive refrigerant amount • Indoor, outdoor unit installation spaces • Faulty compressor • Defective outdoor air temp. sensor • Defective outdoor control PCB 		

Note:

Error code Remote controller: E59	LED	Green	Red	Content Compressor startup failure (Models SRC40~60)
	Indoor	Keeps flashing	Stays OFF	
	Outdoor	—	2 times flash	

Все каталоги и инструкции здесь: <http://splitoff.ru/tehn-doc.html>

1. Applicable model	2. Troubleshooting	
Models SRC40~60	<p style="text-align: center;">Diagnosis</p>	<p style="text-align: center;">Countermeasure</p>
2. Error detection method		
If it fails to change over to the rotor detection operation of compressor motor		
3. Condition of Error displayed		
If compressor fails to startup for 42 times		
4. Presumable cause		
<ul style="list-style-type: none"> • Faulty outdoor fan motor • Faulty outdoor control PCB • Anomalous power supply voltage • Improper refrigerant amount and refrigerant circuit • Faulty compressor (Motor bearing) 		

Note: Insulation resistance

- The unit is left for long period without power supply or soon after installation, migrated liquid refrigerant may dissolve in the refrigerant oil in the compressor. In such case insulation resistance decreases upto several MΩ or lower. If the electric leakage breaker is activated due to low insulation resistance, check followings.
 - ① Check whehter the insulation resistance can recover or not, ater 6 hours has passed since power ON.
(By engerize the crankcase heater, migrated liquid refrigerant in the refrigerant oil in compressor can be evaporated)
 - ② Check whehter the electric leakage breake conforms to high-hermonic specifications
(As units has inverter, in order to prevent from improper operation, be sure to use high-hermonic one.)

Error code Remote controller: E59	LED	Green	Red	Content Compressor startup failure (Models FDC71~250)
	Indoor control PCB	Keeps flashing	Stays OFF	
	Outdoor control PCB	Keeps flashing	1 time flash	
	Outdoor inverter	Yellow LED or Red LED	Green LED	

Все каталоги и инструкции здесь: <http://splitoff.ru/tehn-doc.html>

1. Applicable model
Models FDC71-250
2. Error detection method
If it fails to change over to the rotor detection operation of compressor motor (If the compressor speed cannot increase 11Hz or higher)
3. Condition of Error displayed
If compressor fails to startup for 20 times (10 patterns x 2 times). (It is available to reset by remote controller after 3 minutes delay)
4. Presumable cause
<ul style="list-style-type: none"> Faulty outdoor fan motor Faulty inverter PCB Anomalous power supply voltage Improper refrigerant amount and refrigerant circuit Faulty compressor (Motor bearing)

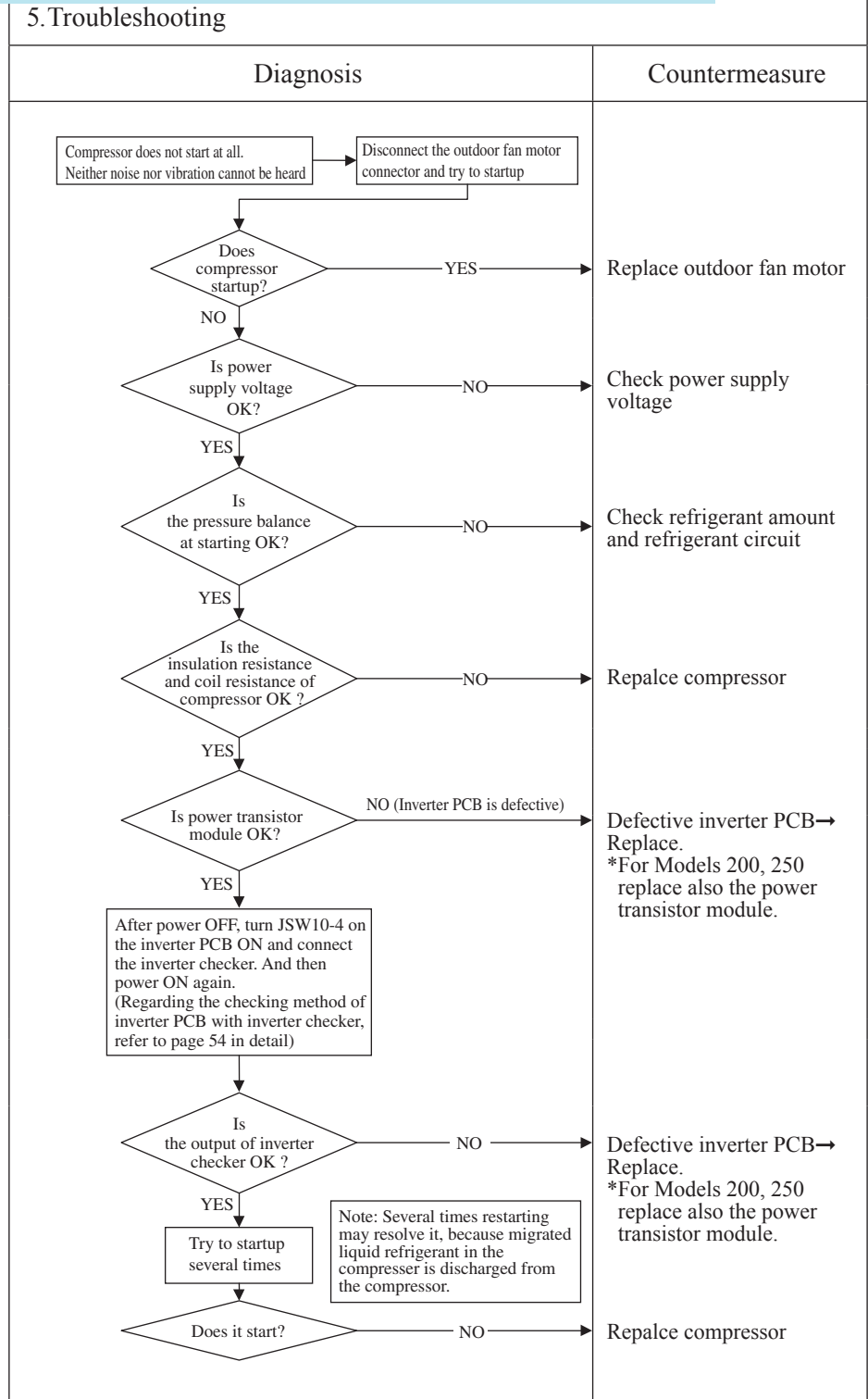

Note: Insulation resistance

- The unit is left for long period without power supply or soon after installation, migrated liquid refrigerant may dissolve in the refrigerant oil in the compressor. In such case insulation resistance decreases upto several MΩ or lower. If the electric leakage breaker is activated due to low insulation resistance, check followings.
 - Check whehter the insulation resistance can recover or not, ater 6 hours has passed since power ON.
(By energize the crankcase heater, migrated liquid refrigerant in the refrigerant oil in compressor can be evaporated)
 - Check whether the electric leakage breake conforms to high-hermonic specifications
(As units has inverter, in order to prevent from improper operation, be sure to use high-hermonic one.)

Error code Remote controller: E60	LED	Green	Red	Content Compressor rotor lock error (Models SRC40~60, FDC200, 250)
	Indoor	Keeps flashing	Stays OFF	
	Outdoor	Keeps flashing	1(7) time flash	

Все каталоги и инструкции здесь: <http://splitoff.ru/tehn-doc.html>

<p>1. Applicable model</p> <p>Models SRC40~60, FDC200, 250</p>	<p>3. Troubleshooting</p> <table border="1" style="width: 100%;"> <thead> <tr> <th style="width: 50%;">Diagnosis</th> <th style="width: 50%;">Countermeasure</th> </tr> </thead> <tbody> <tr> <td style="text-align: center;"> <pre> graph TD Q1{Is the power supply voltage OK?} -- NO --> C1[Check and correct the power supply voltage] Q1 -- YES --> R1[Reset the power supply and restart operation.] R1 --> Q2{Does the compressor start?} Q2 -- NO --> Q3{Does E59 occur?} Q3 -- YES --> C2[Correct it based on the troubleshooting of E59] Q3 -- NO --> Q4{Does the compressor run without occurrence of E42?} Q4 -- NO --> C3[Correct it based on the troubleshooting of E42] Q4 -- YES --> Q5{Is the output from inverter checker OK?} Q5 -- NO --> C4["• SRC40 ~ 60 Defective outdoor control PCB -> Replace. • FDC200, 250 Defective inverter PCB -> Replace. *For model 200, 250 replace also the power transistor module."] Q5 -- YES --> Q6{Is the noise or vibration of compressor normal?} Q6 -- NO --> C5[Replace compressor.] Q6 -- YES --> Q7{Does it start up normally without recurrence of E60.} Q7 -- NO --> C6["Check compressor for insulation, resistance. Replace compressor if necessary."] Q7 -- YES --> C7["• SRC40 ~ 60 Defective outdoor control PCB -> Replace. • FDC200, 250 Defective inverter PCB -> Replace. *For Models 200, 250 replace also the power transistor module."] </pre> </td> <td></td> </tr> </tbody> </table>	Diagnosis	Countermeasure	<pre> graph TD Q1{Is the power supply voltage OK?} -- NO --> C1[Check and correct the power supply voltage] Q1 -- YES --> R1[Reset the power supply and restart operation.] R1 --> Q2{Does the compressor start?} Q2 -- NO --> Q3{Does E59 occur?} Q3 -- YES --> C2[Correct it based on the troubleshooting of E59] Q3 -- NO --> Q4{Does the compressor run without occurrence of E42?} Q4 -- NO --> C3[Correct it based on the troubleshooting of E42] Q4 -- YES --> Q5{Is the output from inverter checker OK?} Q5 -- NO --> C4["• SRC40 ~ 60 Defective outdoor control PCB -> Replace. • FDC200, 250 Defective inverter PCB -> Replace. *For model 200, 250 replace also the power transistor module."] Q5 -- YES --> Q6{Is the noise or vibration of compressor normal?} Q6 -- NO --> C5[Replace compressor.] Q6 -- YES --> Q7{Does it start up normally without recurrence of E60.} Q7 -- NO --> C6["Check compressor for insulation, resistance. Replace compressor if necessary."] Q7 -- YES --> C7["• SRC40 ~ 60 Defective outdoor control PCB -> Replace. • FDC200, 250 Defective inverter PCB -> Replace. *For Models 200, 250 replace also the power transistor module."] </pre>	
Diagnosis	Countermeasure				
<pre> graph TD Q1{Is the power supply voltage OK?} -- NO --> C1[Check and correct the power supply voltage] Q1 -- YES --> R1[Reset the power supply and restart operation.] R1 --> Q2{Does the compressor start?} Q2 -- NO --> Q3{Does E59 occur?} Q3 -- YES --> C2[Correct it based on the troubleshooting of E59] Q3 -- NO --> Q4{Does the compressor run without occurrence of E42?} Q4 -- NO --> C3[Correct it based on the troubleshooting of E42] Q4 -- YES --> Q5{Is the output from inverter checker OK?} Q5 -- NO --> C4["• SRC40 ~ 60 Defective outdoor control PCB -> Replace. • FDC200, 250 Defective inverter PCB -> Replace. *For model 200, 250 replace also the power transistor module."] Q5 -- YES --> Q6{Is the noise or vibration of compressor normal?} Q6 -- NO --> C5[Replace compressor.] Q6 -- YES --> Q7{Does it start up normally without recurrence of E60.} Q7 -- NO --> C6["Check compressor for insulation, resistance. Replace compressor if necessary."] Q7 -- YES --> C7["• SRC40 ~ 60 Defective outdoor control PCB -> Replace. • FDC200, 250 Defective inverter PCB -> Replace. *For Models 200, 250 replace also the power transistor module."] </pre>					
<p>2. Error detection method</p> <p>Compressor rotor position</p>					
<p>3. Condition of Error displayed</p> <p>If it fails again to detect the rotor position after shifting to the compressor rotor position detection operation, the compressor stops.</p> <ul style="list-style-type: none"> • Models FDC200, 250 only When it is restart automatically after 3 minutes, it is detected 4 times within 15 minutes. 					
<p>4. Presumable cause</p> <ul style="list-style-type: none"> • Defective outdoor fan motor • Defective outdoor control PCB • Defective inverter PCB • Anomalous power supply voltage • Improper refrigerant amount and refrigerant circuit • Defective compressor (motor, bearing) 					

Note: Insulation resistance

- The unit is left for long period without power supply or soon after installation, migrated liquid refrigerant may dissolve in the refrigerant oil in the compressor. In such case insulation resistance decreases upto several MΩ or lower. If the electric leakage breaker is activated due to low insulation resistance, check followings.
 - ① Check whether the insulation resistance can recover or not, after 6 hours has passed since power ON.
(By energize the crankcase heater, migrated liquid refrigerant in the refrigerant oil in compressor can be evaporated)
 - ② Check whether the electric leakage breaker conforms to high-harmonic specifications
(As units has inverter, in order to prevent from improper operation, be sure to use high-harmonic one.)

3. ELECTRICAL WIRING

(1) Indoor units
 (a) Ceiling cassette-4 way compact type (FDTC)
 Models FDTCA0VD, 50VVD, 60VVD

Color Marks

Mark	Color
BK	Black
BL	Blue
BR	Brown
OR	Orange
RD	Red
WH	White
Y	Yellow
Y/GN	Yellow / Green

TB1	Terminal block (Power source) (□ mark)
TB2	Terminal block (Signal line) (□ mark)
Thc	Thermistor (Remote controller)
Th-A	Thermistor (Return air)
Th-R1,2,3	Thermistor (Heat exchanger)
X4	Relay for DM
■ mark	Closed-end connector

LED · 3	Indication lamp (Red-Inspection)
LM1 ~4	Louver motor
SW2	Remote controller communication address
SW5	Plural units Master / Slave setting
SW6	Model capacity setting
SW7-1	Operation check, Drain motor test run

CNB ~Z	Connector
DM	Drain motor
F200 ~203	Fuse
FM 1	Fan motor
FS	Floater switch
LED · 2	Indication lamp (Green-Normal operation)

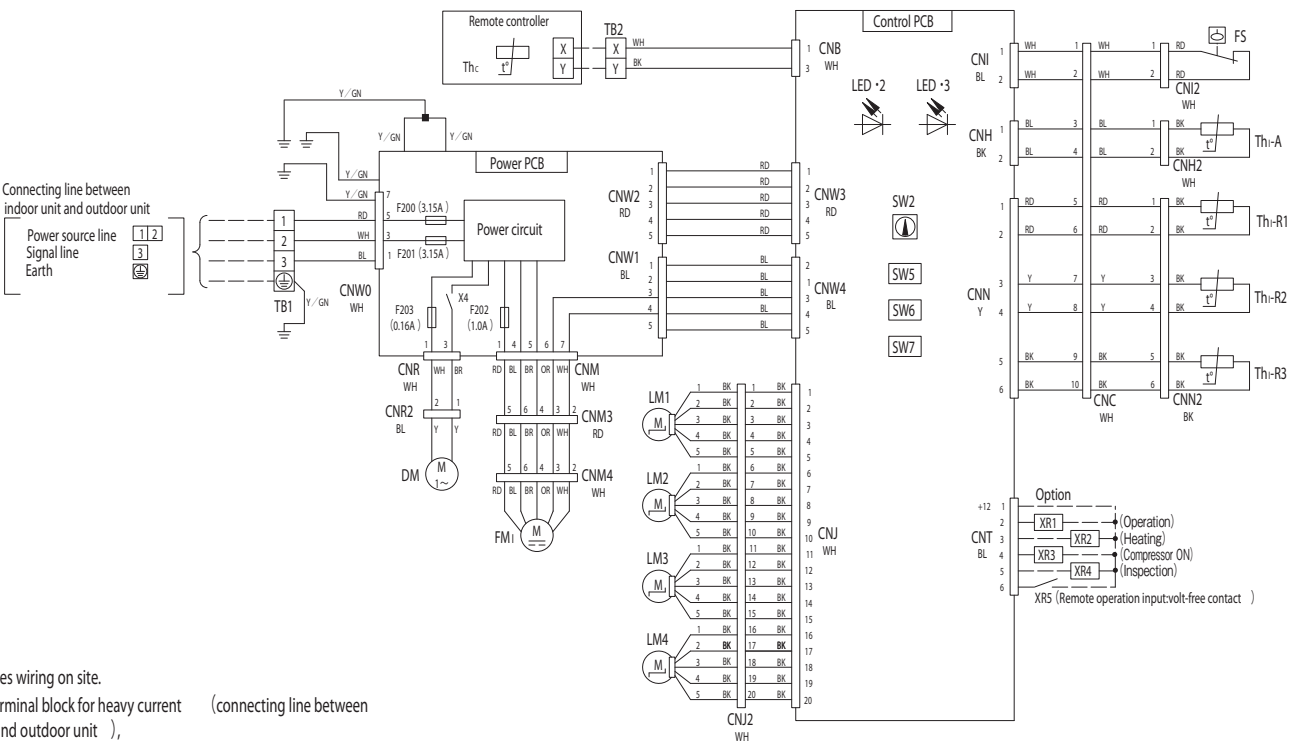

- Notes
- indicates wiring on site.
 - TB1 is the terminal block for heavy current (connecting line between indoor unit and outdoor unit), and TB2 is the terminal block for weak current (remote controller).
 - See the wiring diagram of outside unit about the line between inside unit and outside unit.
 - Use twin core cable (0.3mm²×2) at remote controller line. See spec sheet of remote controller in case that the total length is more than 100m.
 - Do not put remote controller line alongside power source line.

РJA003Z340

(b) Ceiling cassette-4 way type (FDT)
 Models FDT40VD, 50VD, 60VD, 71VD, 100VD, 125VD, 140VD

Всe каталоги и инструкции здесь: <http://splitoff.ru/ehh-doc.html>

CNB~Z	Connector
DM	Drain motor
F200~203	Fuse
FMI	Fan motor
FS	Float switch
LED • 2	Indication lamp (Green-Normal)
LED • 3	Indication lamp (Red-Inspection)
LM1~4	Louver motor
PS	Panel switch
SW2	Remote controller communication address
SW5	Plural units Master/Slave setting
SW6	Model capacity setting
SW7-1	Operation check, Drain motor test
TB1	Terminal block (Power source)
TB2	Terminal block (Signal line)
Th c	Thermistor (Remote controller)
ThI -A	Thermistor (Return air)
ThI -R1,2,3	Thermistor (Heat exchanger)
X4	Relay for DM
■mark	Closed-end connector

Color Marks

Mark	Color	Mark	Color
BK	Black	RD	Red
BL	Blue	WH	White
BR	Brown	Y	Yellow
OR	Orange	Y/GN	Yellow/Green

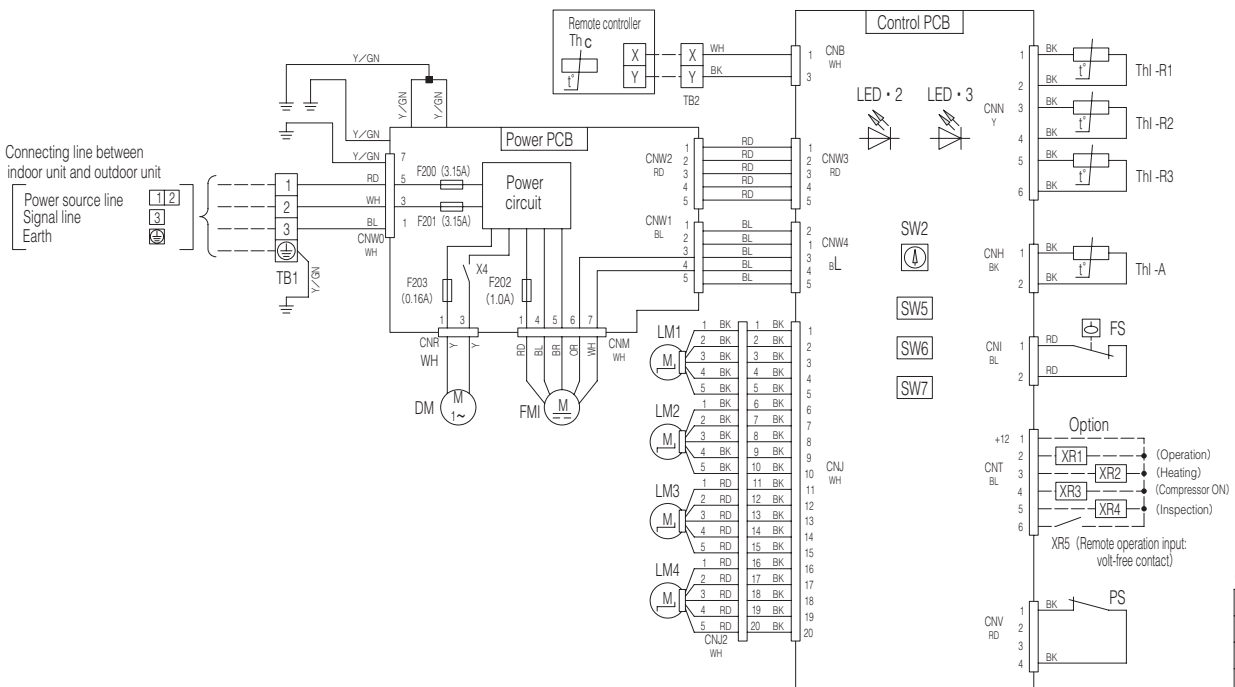

- Notes
1. --- indicates wiring on site.
 2. See the wiring diagram of outside unit about the line between inside unit and outside unit.
 3. Use twin core cable (0.3mm²X2) at remote controller line. See spec sheet of remote controller in case that the total length is more than 100m.
 4. Do not put remote controller line alongside power source line.

PJF000Z190

(c) Ceiling suspended type (FDEN)
Models FDEN40VD, 50VD

CF1 1	Capacitor for FMI
CNB~Z	Connector
F	Fuse
FMI 1	Fan motor (with thermostat)
LED・2	Indication lamp (Green-Normal operation)
LED・3	Indication lamp (Red-Inspection)
LM	Louver motor
SW2	Remote controller communication address
SW5	Plural units Master/Slave setting
SW6	Model capacity setting
SW7-1	Operation check, Drain motor test run
TB1	Terminal block(Power source) (□mark)
TB2	Terminal block(Signal line) (□mark)
Thc	Thermistor(Remote controller)
Thl-A	Thermistor(Return air)
Thl-R1,2,3	Thermistor(Heat exchanger)
Tr1	Transformer
X1~3,6	Relay for FM
X4	Relay for DM

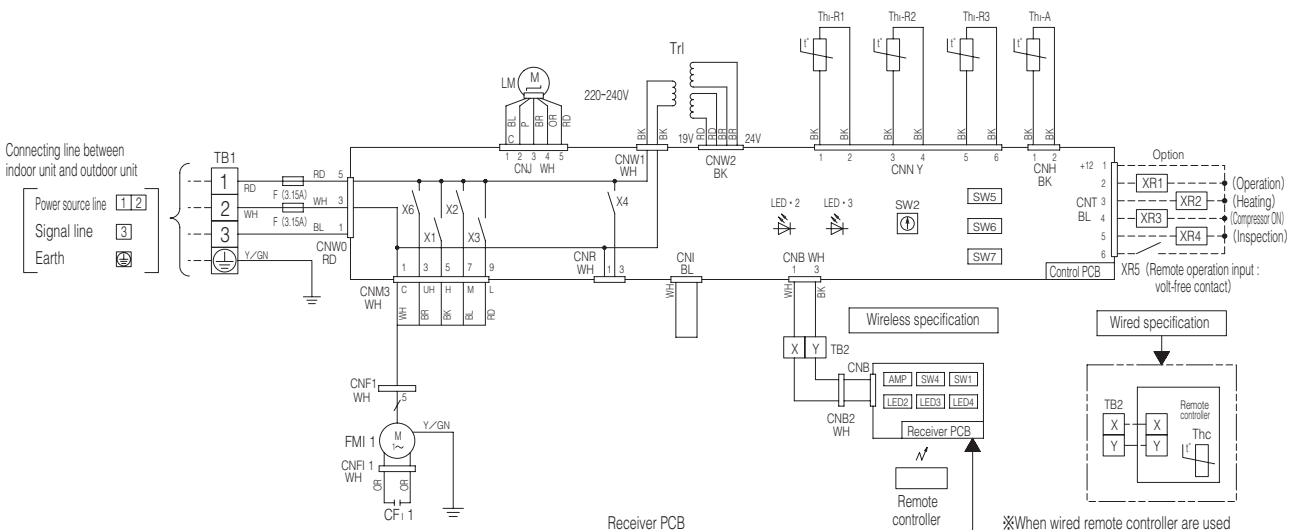

Receiver PCB	
LED2	Indication lamp (Green-Normal operation)
LED3	Indication lamp (Yellow-Timer/Inspection)
LED4	7-segment display
SW1	Switches for setting
SW4	Back-up switch (Operation/Stop)

※When wired remote controller are used only (wireless type)
 It is necessary to remove the line that is connected to the receiver.
 Remove signal line connected to the receiver from primary side of terminal block (X,Y).

ATTENTION

- ① Insulate with tape the removed line.
- ② The LED of that removed connector will not be able to make any indication.

Color Marks

Mark	Color	Mark	Color
BK	Black	RD	Red
BL	Blue	WH	White
BR	Brown	Y	Yellow
OR	Orange	Y/GN	Yellow/Green
P	Pink		

- Notes 1. --- indicates wiring on site.
 2. See the wiring diagram of outside unit about the line between indoor unit and outdoor unit.
 3. Use twin core cable (0.3mm²X2) at remote controller line. See spec sheet of remote controller in case that the total length is more than 100m.
 4. Do not put remote controller line alongside power source line.

PFA003Z819

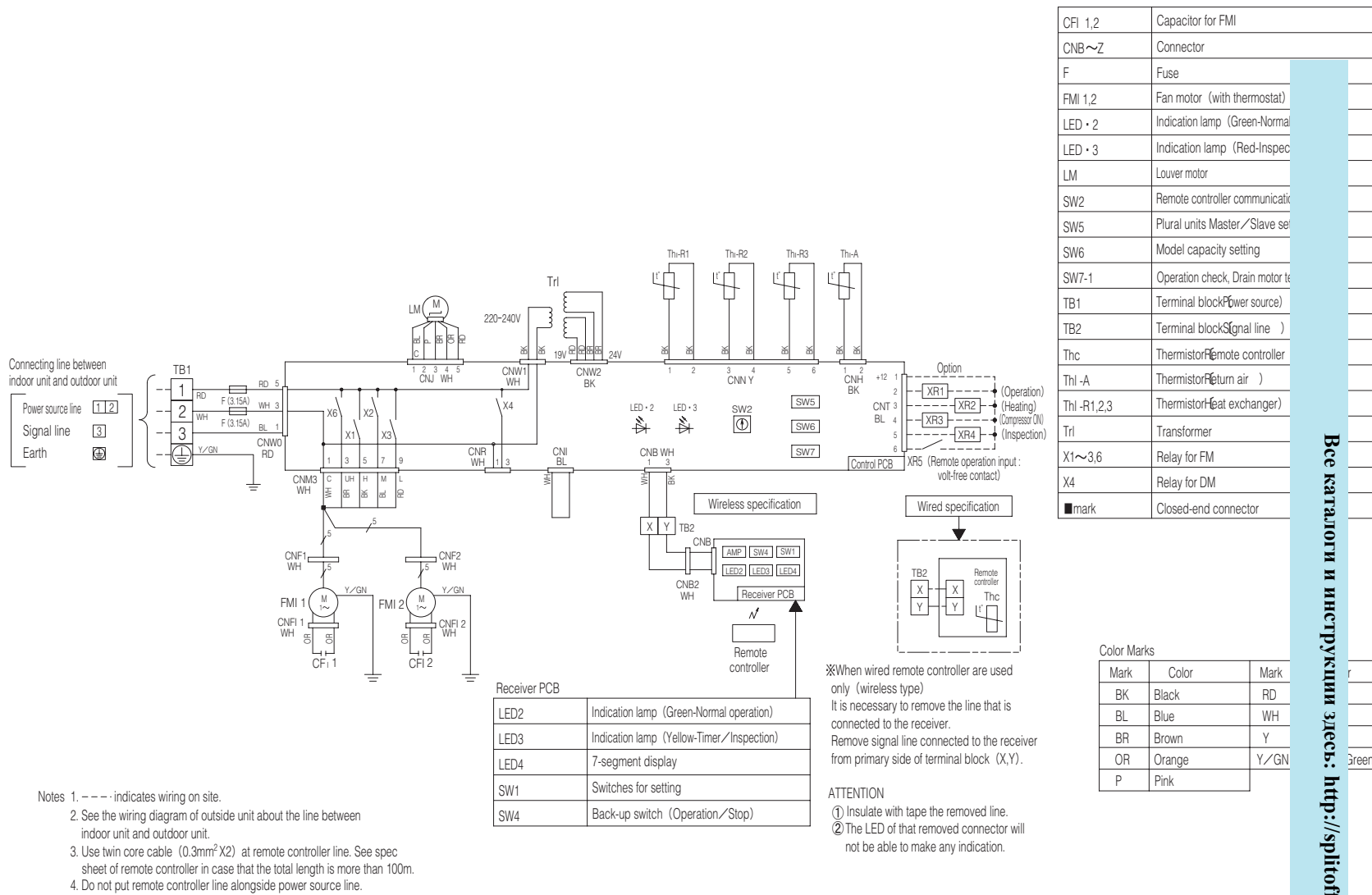

- Notes
1. - - - indicates wiring on site.
 2. See the wiring diagram of outside unit about the line between indoor unit and outdoor unit.
 3. Use twin core cable (0.3mm²X2) at remote controller line. See spec sheet of remote controller in case that the total length is more than 100m.
 4. Do not put remote controller line alongside power source line.

PFA003Z820

Всe каталоги и инструкции здесь: <http://splitoff.ru/ehh-doc.html>

Models FDEN60VD, 71VD, 100VD, 125VD, 140VD

(d) Duct connected-Low / Middle static pressure type (FDUM)
Models FDUM50VD, 60VD, 71VD

CF1	Capacitor for FM1
CNB~Z	Connector
DM	Drain motor
F	Fuse
FM1	Fan motor(with thermostat)
FS	Float switch
LED•2	Indication lamp(Green-Normal operation)
LED•3	Indication lamp(Red-Inspection)
SW2	Remote controller communication address
SW5	Plural units Master/Slave setting
SW6	Model capacity setting
SW7-1	Operation check, Drain motor test run
TB1	Terminal block(Power source) (□mark)
TB2	Terminal block(Signal line) (□mark)
Thc	Thermistor(Remote controller)
Thl-A	Thermistor(Return air)
Thl-R1,2,3	Thermistor(Heat exchanger)
Tr1	Transformer
X1~3,6	Relay for FM
X4	Relay for DM

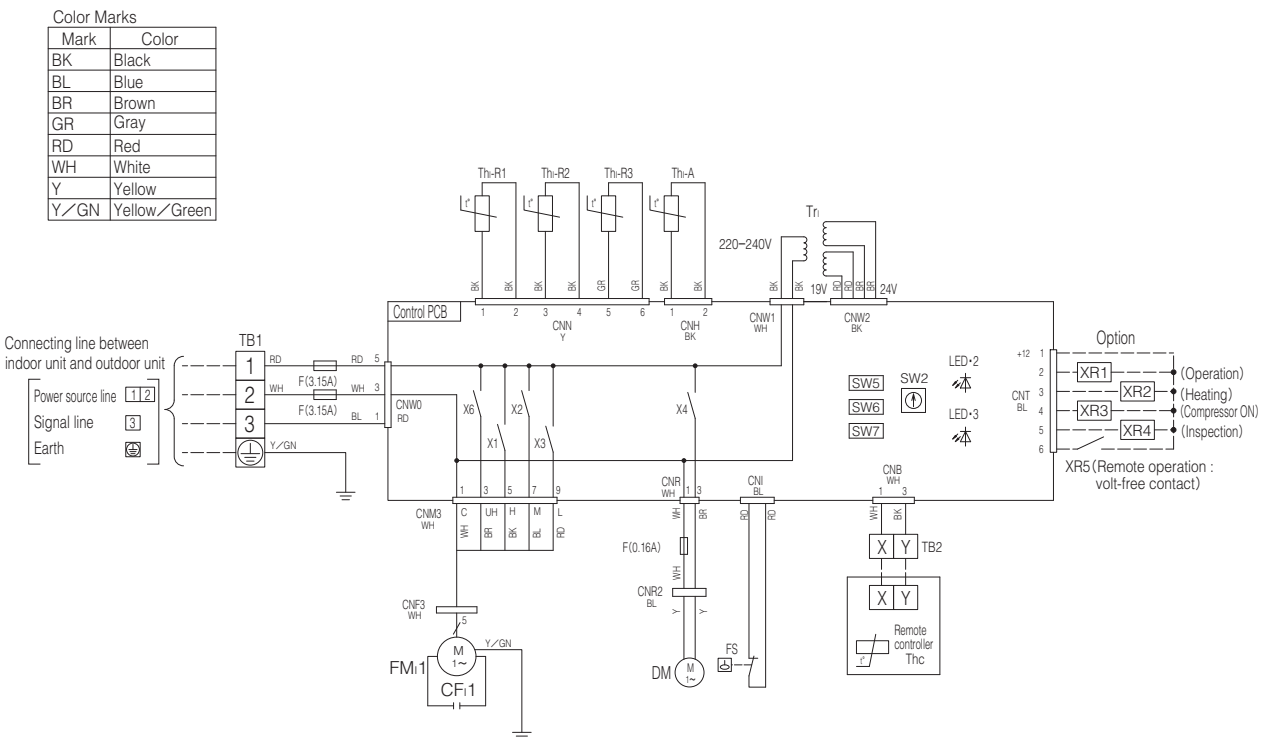

- Notes
1. — indicates wiring on site.
 2. See the wiring diagram of outside unit about the line between inside unit and outside unit.
 3. Use twin core cable(0.3mm² X2) at remote controller line. See spec sheet of remote controller in case that the total length is more than 100m.
 4. Do not put remote controller line alongside power source line.

PJRR0022244 

Mark	Color
BK	Black
BL	Blue
BR	Brown
GR	Gray
RD	Red
WH	White
Y	Yellow
Y/GN	Yellow/Green

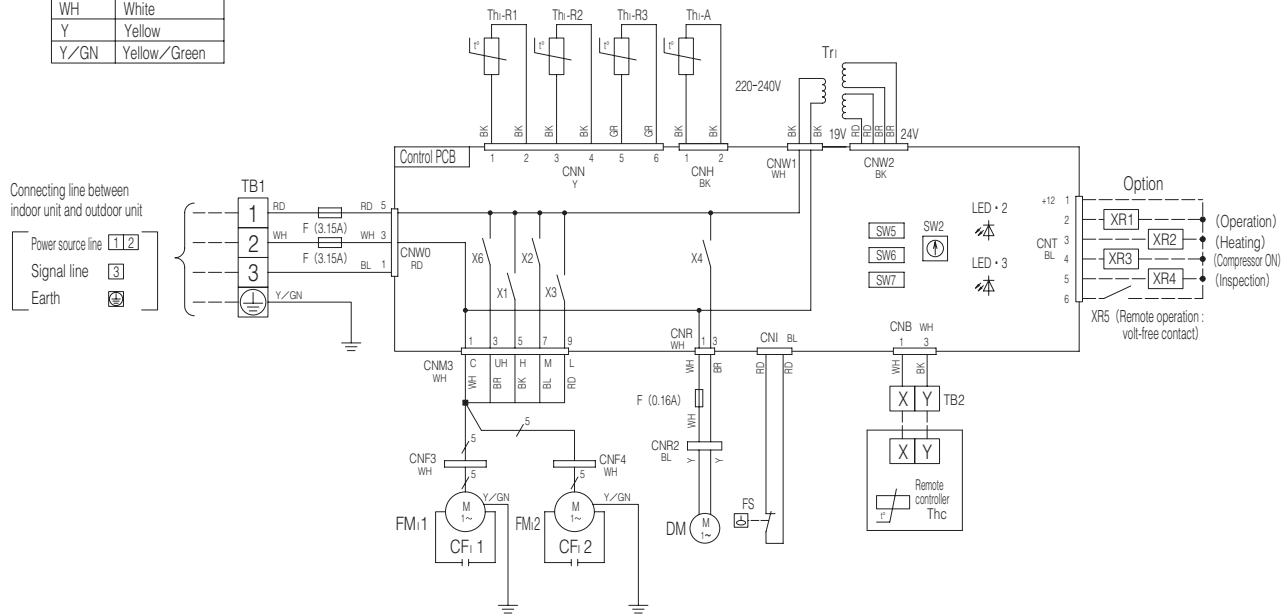

- Notes
1. - - - - indicates wiring on site.
 2. See the wiring diagram of outside unit about the line between inside unit and outside unit.
 3. Use twin core cable (0.3mm²X2) at remote controller line. See spec sheet of remote controller in case that the total length is more than 100m.
 4. Do not put remote controller line alongside power source line.

PJR0022245

CF1,2	Capacitor for FMI
CNB~Z	Connector
DM	Drain motor
F	Fuse
FMI 1,2	Fan motor (with thermostat)
FS	Float switch
LED • 2	Indication lamp (Green-Normal)
LED • 3	Indication lamp (Red-Inspection)
SW2	Remote controller communication
SW5	Plural units Master/Slave
SW6	Model capacity setting
SW7-1	Operation check, Drain motor
TB1	Terminal block Power source
TB2	Terminal block Signal line
Thc	Thermistor Remote controller
Thl-A	Thermistor Return air
Thl-R1,2,3	Thermistor Heat exchanger
Tr1	Transformer
X1~3,6	Relay for FM
X4	Relay for DM
■mark	Closed-end connector

Все каталоги и инструкции здесь: <http://splitoff.ru/ehh-doc.html>

Models FDUM100VD, 125VD, 140VD

(e) Duct connected-High static pressure type (FDU)
Model FDU71VD

CF1	Capacitor for FMI
CNB~Z	Connector
DM	Drain motor
F	Fuse
FMI	Fan motor (with thermostat)
FS	Float switch
LED · 2	Indication lamp (Green-Normal operation)
LED · 3	Indication lamp (Red-Inspection)
SW2	Remote controller communication address
SW6	Model capacity setting
SW7-1	Operation check, Drain motor test run
TB1	Terminal blockPower source (□mark)
TB2	Terminal blockSignal line (□mark)
Thc	ThermistorRemote controller ()
Thl -A	ThermistorReturn air ()
Thl -R1,2,3	ThermistorHeat exchanger ()
Trl	Transformer
X1~3,6	Relay for FM
X4	Relay for DM
■mark	Closed-end connector

Color Marks

Mark	Color	Mark	Color
BK	Black	P	Pink
BL	Blue	RD	Red
BR	Brown	WH	White
GR	Gray	Y	Yellow
OR	Orange	Y/GN	Yellow/Green

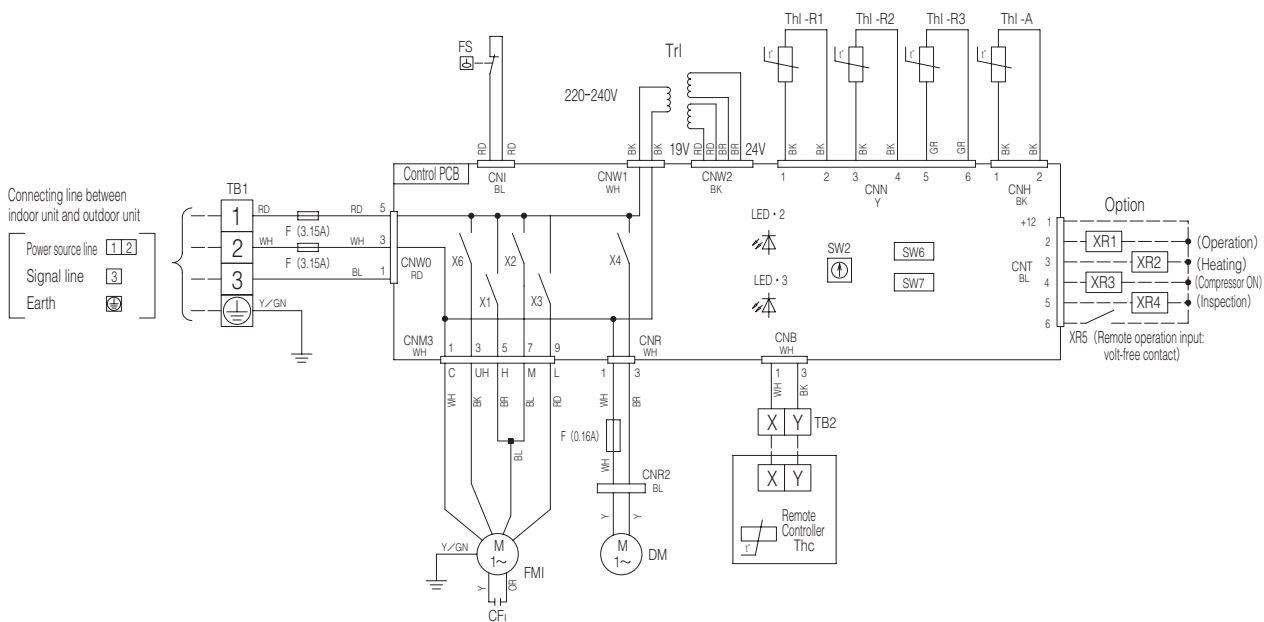

Notes 1. - - - - indicates wiring on site.

2. See the wiring diagram of outside unit about the line between inside unit and outside unit.
3. Use twin core cable (0.3mm²X2) at remote controller line. See spec sheet of remote controller in case that the total length is more than 100m.
4. Do not put remote controller line alongside power source line.

PJD001D304

Color Marks

Mark	Color	Mark	Color
BK	Black	P	Pink
BL	Blue	RD	Red
BR	Brown	WH	White
GR	Gray	Y	Yellow
OR	Orange	Y/GN	Yellow/Green

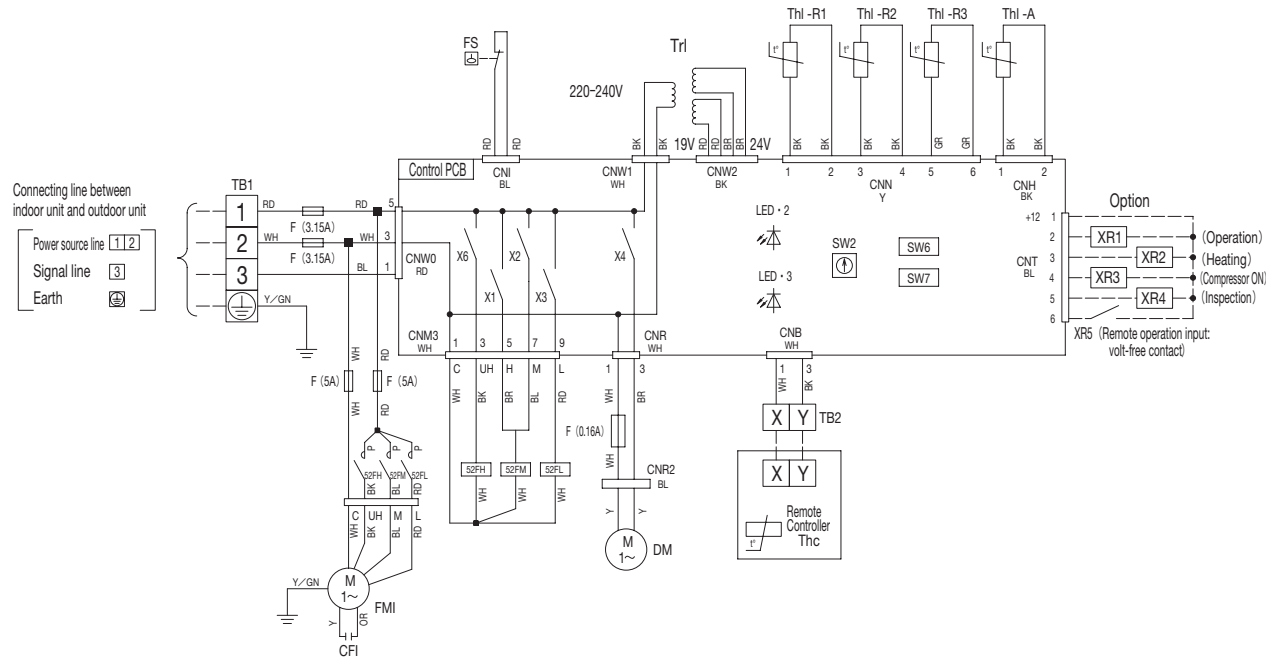

- Notes
1. - - - - indicates wiring on site.
 2. See the wiring diagram of outside unit about the line between inside unit and outside unit.
 3. Use twin core cable (0.3mm²X2) at remote controller line. See spec sheet of remote controller in case that the total length is more than 100m.
 4. Do not put remote controller line alongside power source line.

CF1	Capacitor for FMI
CNB~Z	Connector
DM	Drain motor
F	Fuse
FMI	Fan motor (with thermostat)
FS	Float switch
LED · 2	Indication lamp (Green-Normal open)
LED · 3	Indication lamp (Red-Inspection)
SW2	Remote controller communication switch
SW6	Model capacity setting
SW7-1	Operation check, Drain motor test
TB1	Terminal block (Power source)
TB2	Terminal block (Signal line)
Thc	Thermistor (Remote controller)
Th1 -A	Thermistor (Return air)
Th1 -R1,2,3	Thermistor (Heat exchanger)
Tr1	Transformer
X1~3,6	Relay for FM
X4	Relay for DM
■mark	Closed-end connector
52FL,FM,FH	Electromagnetic contactor for

Все каталоги и инструкции здесь: <http://splitoff.ru/ehd-doc.html>

Models FDU100VD, 125VD, 140VD

PJD001Z218 

Color Marks

Mark	Color	Mark	Color
BK	Black	P	Pink
BL	Blue	RD	Red
BR	Brown	WH	White
GR	Gray	Y	Yellow
OR	Orange	Y/GN	Yellow / Green

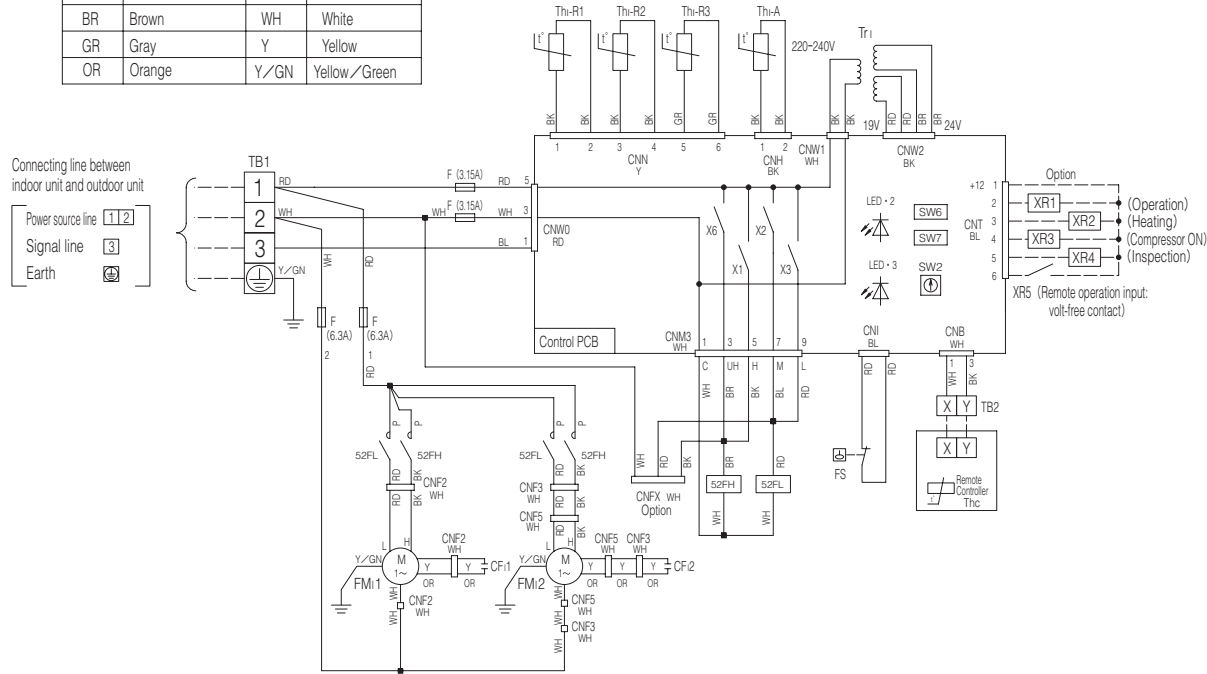

- Notes
- indicates wiring on site.
 - See the wiring diagram of outside unit about the line between inside unit and outside unit.
 - Use twin core cable (0.3mm²X2) at remote controller line. See spec sheet of remote controller in case that the total length is more than 100m.
 - Do not put remote controller line alongside power source line.

CF1,2	Capacitor for FMI
CNB~Z	Connector
F	Fuse
FC	Fan controller
FMI 1,2	Fan motor (with thermostat)
FS	Float switch
LED • 2	Indication lamp (Green-Normal operation)
LED • 3	Indication lamp (Red-Inspection)
SW2	Remote controller communication address
SW6	Model capacity setting
SW7-1	Operation check, Drain motor test run
TB1	Terminal block (Power source) (□mark)
TB2	Terminal block (Signal line) (□mark)
Thc	Thermistor (Remote controller)
Thl -A	Thermistor (Return air)
Thl -R1,2,3	Thermistor (Heat exchanger)
Tr1	Transformer
X1~3,6	Relay for FMI
■mark	Closed-end connector
52FL_FH	Electromagnetic contactor for FMI

Models FDU200VD, 250VD

(2) Outdoor units

Models SRC40ZIX-S, 50ZIX-S, 60ZIX-S

Все каталоги и инструкции здесь: <http://splitoff.ru/ehd-doc.html>

Item	Description
CM	Compressor motor
CNEEV~20S	Connector
EEV	Electric expansion valve
FMo	Fan motor
L	Reactor
T1,2	Terminal block
TH1	Heat exchanger sensor (unit)
TH2	Outdoor air temp. sensor
TH3	Discharge pipe temp. sensor
20S	Solenoid valve for 4 way

Mark	Color
BK	Black
BR	Brown
OR	Orange
RD	Red
WH	White
Y	Yellow
Y/G	Yellow/Green

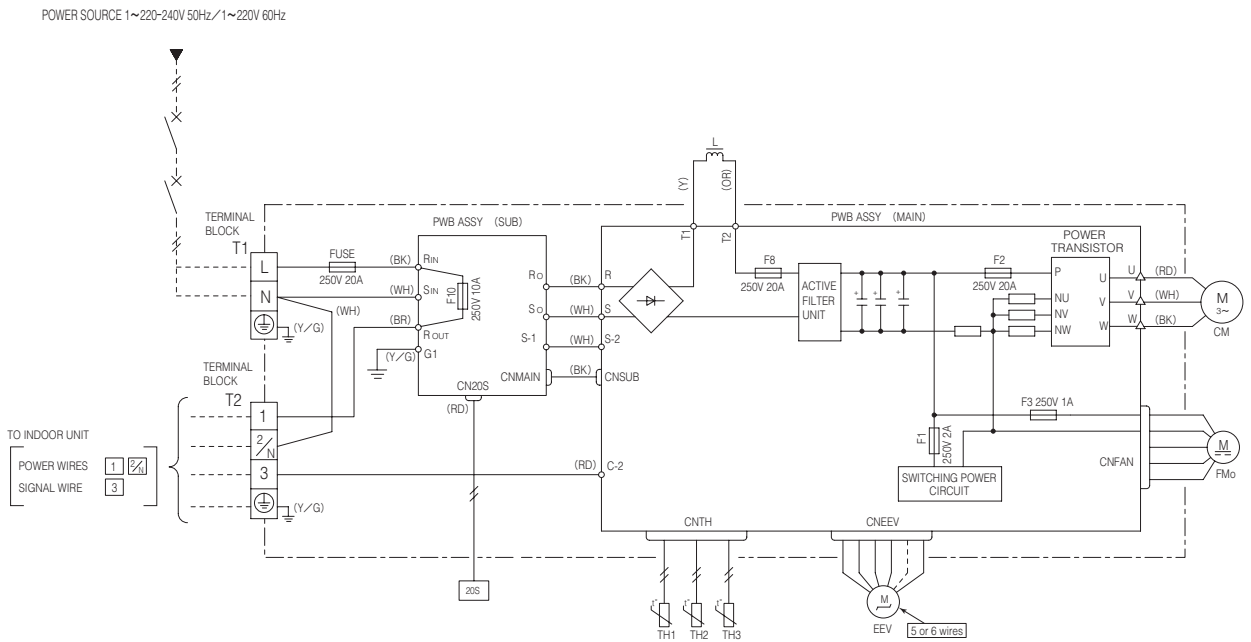

Power cable, indoor-outdoor connecting wires

Model	MAX running current (A)	Power cable size (mm ²)	Power cable length (m)	indoor-outdoor wire size x number	Earth wire size (mm)
40	12	2.0	21	φ 1.6mm x 3	φ 1.6mm
50	14		18		
60					

- The specifications shown in the above table are for units without heaters. For units with heaters, refer to the installation instructions or the construction instructions of the indoor unit.
- Switchgear of Circuit breaker capacity which is calculated from MAX. over current should be chosen along the regulations in each country.
- The cable specifications are based on the assumption that a metal or plastic conduit is used with no more than three cables contained in a conduit and a voltage drop is 2%. For an installation falling outside of these conditions, please follow the internal cabling regulations. Adapt it to the regulation in effect in each country.

RWC000Z214 

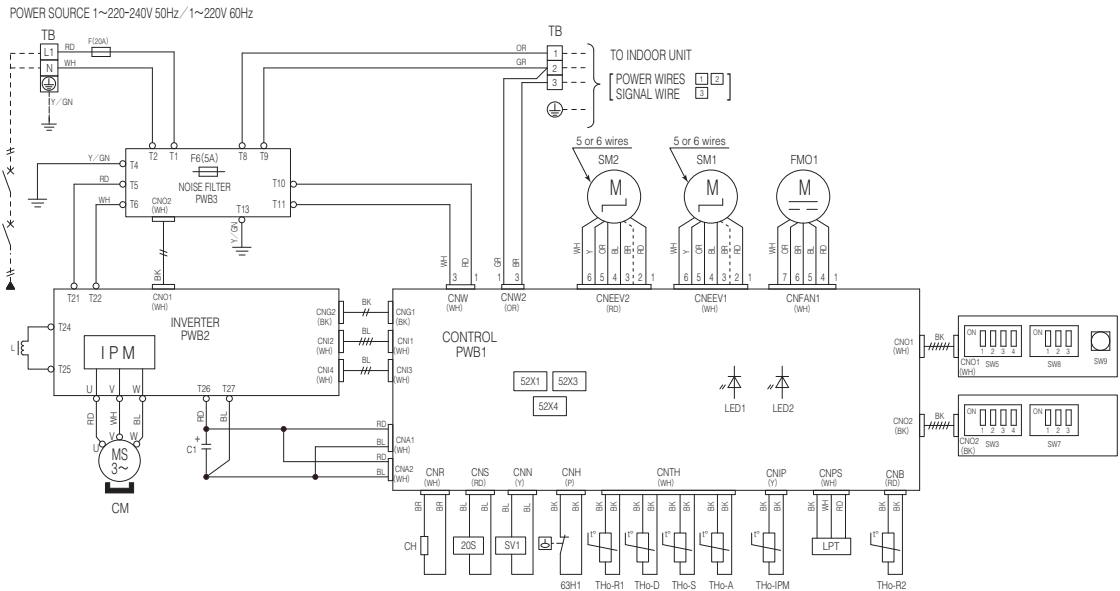

Mark	Color
BK	Black
BL	Blue
BR	Brown
GR	Gray
P	Pink
OR	Orange
RD	Red
WH	White
Y	Yellow
Y/GN	Yellow/Green

Item	Description
CNA~Z	Connector
CH	Crankcase heater
CM	Compressor motor
F	Fuse
FM01	Fan motor
IPM	Intelligent power module
L	Reactor
LED1	Indication lamp (GREEN)
LED2	Indication lamp (RED)
LPT	Low pressure sensor
SM1	Expansion valve for cooling
SM2	Expansion valve for heating
SV1	Solenoid valve
SW9	Pump down switch
SW3,5,7,8	Local setting switch
TB	Terminal block
THo-A	Thermistor (Outdoor air temp.)
THo-D	Thermistor (Discharge pipe temp.)
THo-IPM	Thermistor (IPM)
THo-R1,2	Thermistor (Heat exchanger pipe temp.)
THo-S	Thermistor (Suction pipe temp.)
20S	Solenoid valve for 4 way valve
52X1	Auxilliary relay (for CH)
52X3	Auxilliary relay (for 20S)
52X4	Auxilliary relay (for SV1)
63H1	High pressure switch

Local setting switch SW3 (Set up at shipment OFF)

SW3-1	Defrost control change	The defrosting operation interval becomes shorter by turning ON this switch. This switch should be turned ON in the area where outside temperature becomes below the freezing point.
SW3-2	Snow guard fan control	When this switch is turned ON, the outdoor unit fan will run for 30 seconds in every 10 minutes, when outdoor temperature falls to 3 or lower and the compressor is not running when the unit is used in a very snowy country, set this switch to ON.
SW3-3,4	Trial operation	Method of trial operation ① Trial operation can be performed by using SW3-3,4. ② Compressor will be in the operation when SW3-3 is ON. ③ Cooling trial operation will be performed when SW3-4 is OFF, and heating trial operation when SW3-4 is ON. ④ Be sure to turn OFF SW3-3 after the trial operation is finished.

Power cable, indoor-outdoor connecting wires

Model	MAX over current (A)	Power cable size (mm ²)	Power cable length (m)	indoor-outdoor wire size x number	Earth wire size (mm)
71	17	3.5	21	φ 1.6mm x 3	φ 1.6

- The specifications shown in the above table are for units without heaters. For units with heaters, refer to the installation instructions or the construction instructions of the indoor unit.
- Switchgear or Circuit breaker capacity which is calculated from MAX. over current should be chosen along the regulations in each country.
- The cable specifications are based on the assumption that a metal or plastic conduit is used with no more than three cables contained in a conduit and a voltage drop is 2%. For an installation falling outside of these conditions, please follow the internal cabling regulations. Adapt it to the regulation in effect in each country.

PCA001Z538



POWER SOURCE 1~220-240V 50Hz / 1~220V 60Hz

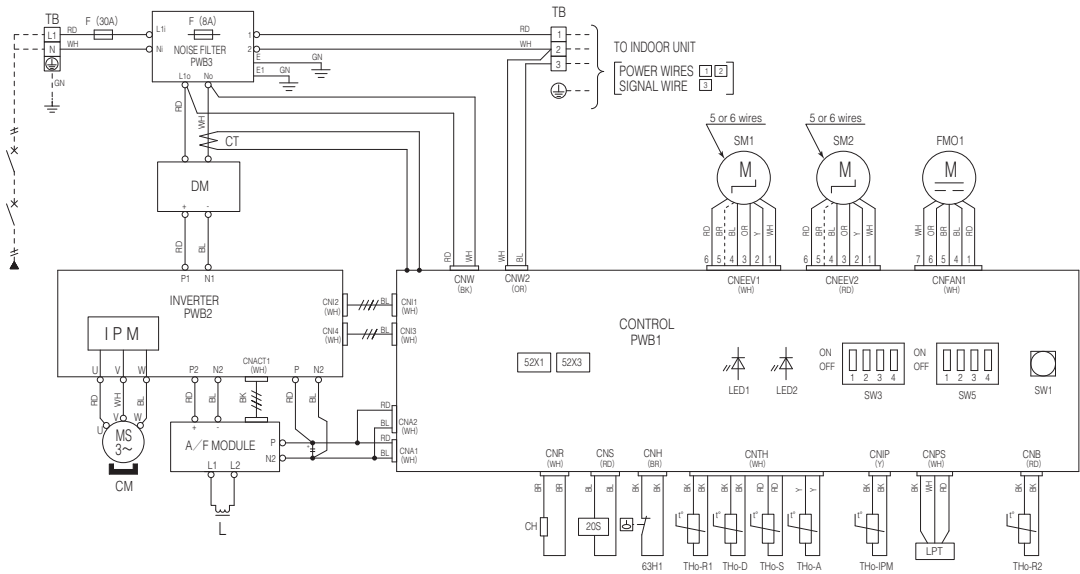

Mark	Color
BK	Black
BL	Blue
BR	Brown
GN	Green
GR	Gray
P	Pink
OR	Orange
RD	Red
WH	White
Y	Yellow
Y/GN	Yellow/Green

Item	Description
CnA~Z	Connector
CH	Crankcase heater
CM	Compressor motor
CT	Current sensor
DM	Diode module
F	Fuse
FM01	Fan motor
IPM	Intelligent power module
L	Reactor
LED1	Indication lamp
LED2	Indication lamp
LPT	Low pressure switch
SM1	Expansion valve
SM2	Expansion valve
SW1	Pump down switch
SW3.5	Local setting switch
TB	Terminal block
THo-A	Thermistor (Outdoor air temp.)
THo-D	Thermistor (Discharge pipe temp.)
THo-IPM	Thermistor (IPM temp.)
THo-R1,2	Thermistor (Heating coil temp.)
THo-S	Thermistor (Suction pipe temp.)
20S	Solenoid valve
52X1	Auxiliary relay
52X3	Auxiliary relay
63H1	High pressure switch

Power cable, indoor-outdoor connecting wires

Model	MAX over current (A)	Power cable size (mm ²)	Power cable length (m)	indoor-outdoor wire size x number	Earth wire size (mm)
100	24	5.5	25	φ 1.6mm x 3	φ 1.6
125					
140					

※At the connection with the duct type indoor unit.

Model	MAX over current (A)	Power cable size (mm ²)	Power cable length (m)	indoor-outdoor wire size x number	Earth wire size (mm)
100	25	5.5	24	φ 1.6mm x 3	φ 1.6
125	27		22		
140	28		32		

- The specifications shown in the above table are for units without heaters. For units with heaters, refer to the installation instructions or the construction instructions of the indoor unit.
- Switchgear of Circuit breaker capacity which is calculated from MAX. over current should be chosen along the regulations in each country.
- The cable specifications are based on the assumption that a metal or plastic conduit is used with no more than three cables contained in a conduit and a voltage drop is 2%. For an installation falling outside of these conditions, please follow the internal cabling regulations. Adapt it to the regulation in effect in each country.

Local setting switch SW3 (Set up at shipment OFF)

SW3-1	Defrost control change	The defrosting operation interval becomes shorter by turning ON this switch. This switch should be turned ON in the area where outside temperature becomes below the freezing point.
SW3-2	Snow guard fan control	When this switch is turned ON, the outdoor unit fan will run for 30 seconds in every 10 minutes, when outdoor temperature falls to 3°C or lower and the compressor is not running when the unit is used in a very snowy country, set this switch to ON.
SW3-3,4	Trial operation	Method of trial operation ① Trial operation can be performed by using SW3-3,4 ② Compressor will be in the operation when SW3-3 is ON. ③ Cooling trial operation will be performed when SW3-4 is OFF, and heating trial operation when SW3-4 is ON. ④ Be sure to turn OFF SW3-3 after the trial operation is finished.

PCA001Z539

Всё каталог и инструкции здесь: <http://splitoff.ru/ehh-doc.html>

Models FDC100VN, 125VN, 140VN

PCA001Z540



POWER SOURCE 3N~380-415V 50Hz

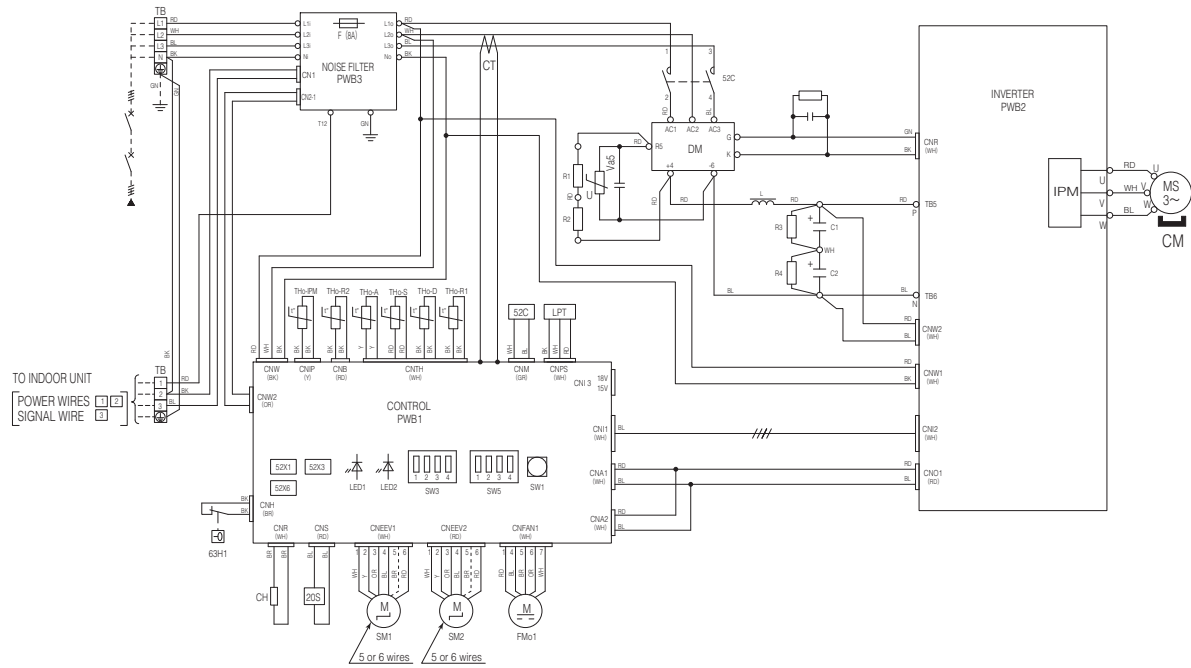

Mark	Color
BK	Black
BL	Blue
BR	Brown
GR	Gray
P	Pink
OR	Orange
RD	Red
WH	White
Y	Yellow
Y / GN	Yellow / Green

Item	Description
CnA~Z	Connector
CH	Crankcase heater
CM	Compressor motor
CT	Current sensor
DM	Diode module
F	Fuse
FM01	Fan motor
IPM	Intelligent power module
L	Reactor
LED1	Indication lamp (GREEN)
LED2	Indication lamp (RED)
LPT	Low pressure sensor
SM1	Expansion valve for cooling
SM2	Expansion valve for heating
SW1	Pump down switch
SW3,5	Local setting switch
TB	Terminal block
THo-A	Thermistor (Outdoor air temp.)
THo-D	Thermistor (Discharger pipe temp.)
THo-IPM	Thermistor (IPM)
THo-R1,2	Thermistor (Heat exchanger pipe temp.)
THo-S	Thermistor (Suction pipe temp.)
20S	Solenoid valve for 4 way valve
52X1	Auxiliary relay (for CH)
52X3	Auxiliary relay (for 20S)
52X6	Auxiliary relay (for 52C)
63H1	High pressure switch

Power cable, indoor-outdoor connecting wires

Model	MAX over current (A)	Power cable size (mm ²)	Power cable length (m)	indoor-outdoor wire size x number	Earth wire size (mm)
100	15	3.5	27	φ 1.6mm x 3	φ 1.6
125					
140					

※At the connection with the duct type indoor unit.

Model	MAX over current (A)	Power cable size (mm ²)	Power cable length (m)	indoor-outdoor wire size x number	Earth wire size (mm)
100	16	3.5	26	φ 1.6mm x 3	φ 1.6
125	18		23		
140	19		21		

- The specifications shown in the above table are for units without heaters. For units with heaters, refer to the installation instructions or the construction instructions of the indoor unit.
- Switchgear of Circuit breaker capacity which is calculated from MAX. over current should be chosen along the regulations in each country.
- The cable specifications are based on the assumption that a metal or plastic conduit is used with no more than three cables contained in a conduit and a voltage drop is 2%. For an installation falling outside of these conditions, please follow the internal cabling regulations. Adapt it to the regulation in effect in each country.

Local setting switch SW3 (Set up at shipment OFF)

SW3-1	Defrost control change	The defrosting operation interval becomes shorter by turning ON this switch. This switch should be turned ON in the area where outside temperature becomes below the freezing point.
SW3-2	Snow guard fan control	When this switch is turned ON, the outdoor unit fan will run for 30 seconds in every 10 minutes, when outdoor temperature falls to 3°C or lower and the compressor is not running when the unit is used in a very snowy country, set this switch to ON.
SW3-3,4	Trial operation	Method of trial operation ① Trial operation can be performed by using SW3-3,4. ② Compressor will be in the operation when SW3-3 is ON. ③ Cooling trial operation will be performed when SW3-4 is OFF, and heating trial operation when SW3-4 is ON. ④ Be sure to turn OFF SW3-3 after the trial operation is finished.

Models FDC100VS, 125VS, 140VS

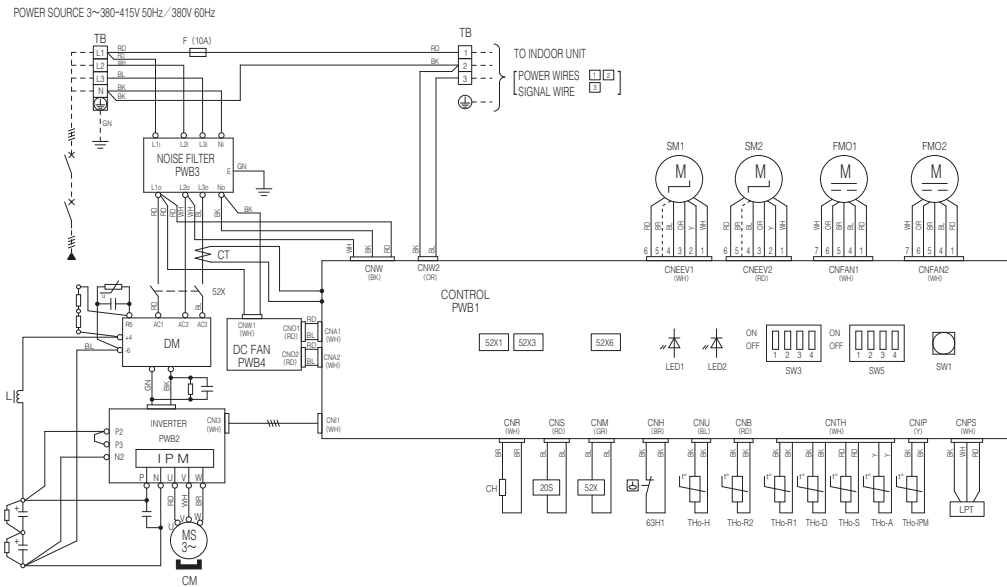

Mark	Color
BK	Black
BL	Blue
BR	Brown
GR	Gray
OR	Orange
RD	Red
WH	White
Y	Yellow
Y/GN	Yellow/Green

Power cable, indoor-outdoor connecting wires

Model	MAX over current (A)	Power cable size (mm) ²	Power cable length (m)	indoor-outdoor wire size x number	Earth wire size (mm)
200	19	3.5	21	φ 1.6mm x 3	φ 1.6
	22	5.5	31		

※At the connection with the duct type indoor unit.

Model	MAX over current (A)	Power cable size (mm) ²	Power cable length (m)	indoor-outdoor wire size x number	Earth wire size (mm)
200	24	5.5	29	φ 1.6mm x 3	φ 1.6
	27		26		

- The specifications shown in the above table are for units without heaters. For units with heaters, refer to the installation instructions or the construction instructions of the indoor unit.
- Switchgear of Circuit breaker capacity which is calculated from MAX. over current should be chosen along the regulations in each country.
- The cable specifications are based on the assumption that a metal or plastic conduit is used with no more than three cables contained in a conduit and a voltage drop is 2%. For an installation falling outside of these conditions, please follow the internal cabling regulations. Adapt it to the regulation in effect in each country.

Local setting switch SW3 (Set up at shipment OFF)

SW3-1	Defrost control change	The defrosting operation interval becomes shorter by turning ON this switch. This switch should be turned ON in the area where outside temperature becomes below the freezing point.
SW3-2	Snow guard fan control	When this switch is turned ON, the outdoor unit fan will run for 30 seconds in every 10 minutes, when outdoor temperature falls to 3 or lower and the compressor is not running when the unit is used in a very snowy country, set this switch to ON.
SW3-3,4	Trial operation	Method of trial operation ① Trial operation can be performed by using SW3-3,4. ② Compressor will be in the operation when SW3-3 is ON. ③ Cooling trial operation will be performed when SW3-4 is OFF, and heating trial operation when SW3-4 is ON. ④ Be sure to turn OFF SW3-3 after the trial operation is finished.

Item	Description
CnA~Z	Connector
CH	Crankcase heater
CM	Compressor motor
CT	Current sensor
DM	Diode module
F	Fuse
FM01,02	Fan motor
IPM	Intelligent power modu
L	Reactor
LED1	Indication lamp (GRE)
LED2	Indication lamp (RED)
LPT	Low pressure sensor
SM1	Expansion valve for co
SM2	Expansion valve for he
SW1	Pump down switch
SW3.5	Local setting switch
TB	Terminal block
ThO-A	Thermistor (Outdoor a
ThO-D	Thermistor (Discharge
ThO-H	Thermistor (Camp.ur
ThO-IPM	Thermistor (IPM)
ThO-R1,2	Thermistor (Heat exchan
ThO-S	Thermistor (Suction pi
20S	Solenoid valve for 4 we
52X1	Auxiliary relay (for Ch
52X3	Auxiliary relay (for 20
52X6	Auxiliary relay (for 52
63H1	High pressure switch

Без каталоги и инструкции здесь: <http://splitoff.ru/ehh-doc.html>

4. PIPING SYSTEM

(1) Single type

Models SRC40, 50, 60ZIX-S

Все каталоги и инструкции здесь: <http://splitoff.ru/tehn-doc.html>

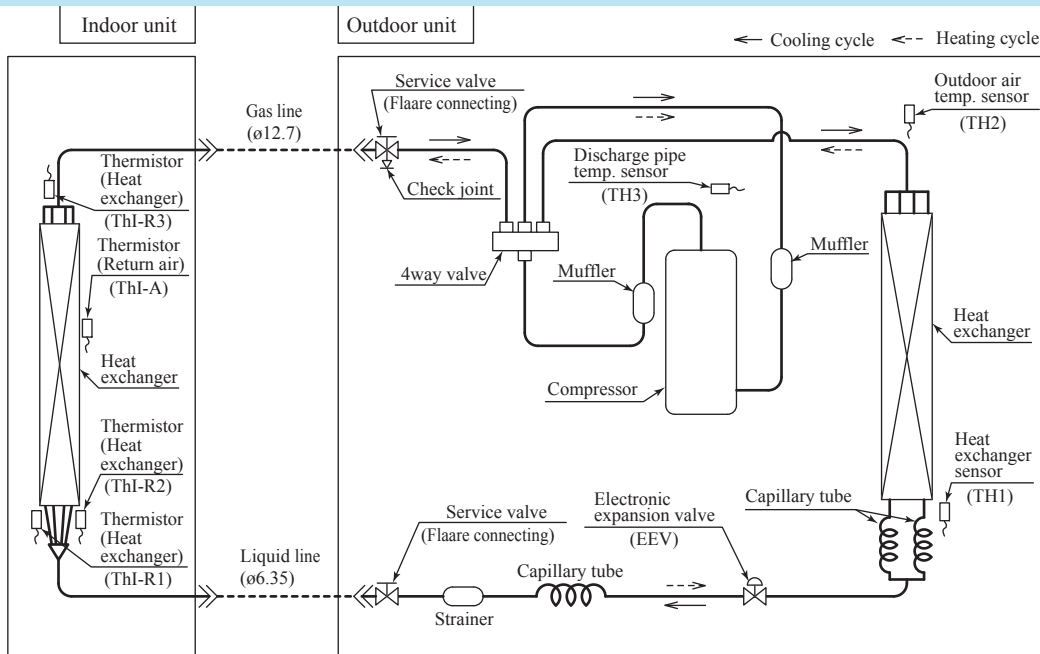

Model FDC 71

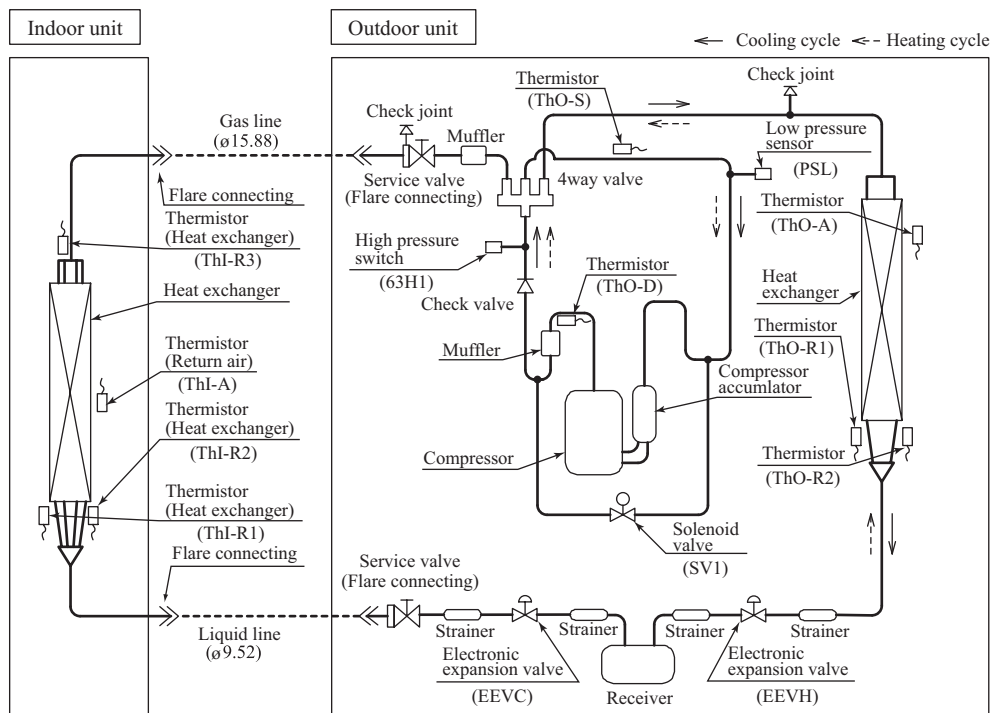

Models FDC 100, 125, 140

Все каталоги и инструкции здесь: <http://splitoff.ru/tehn-doc.html>

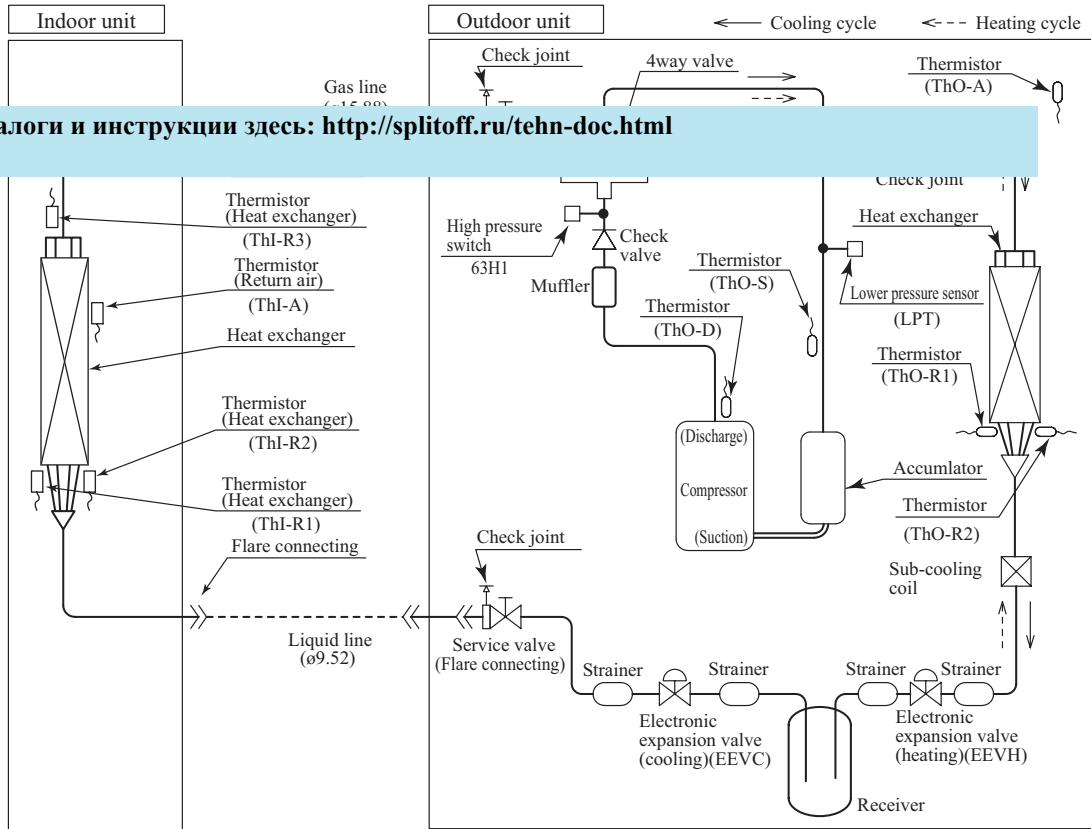

Models FDC 200, 250

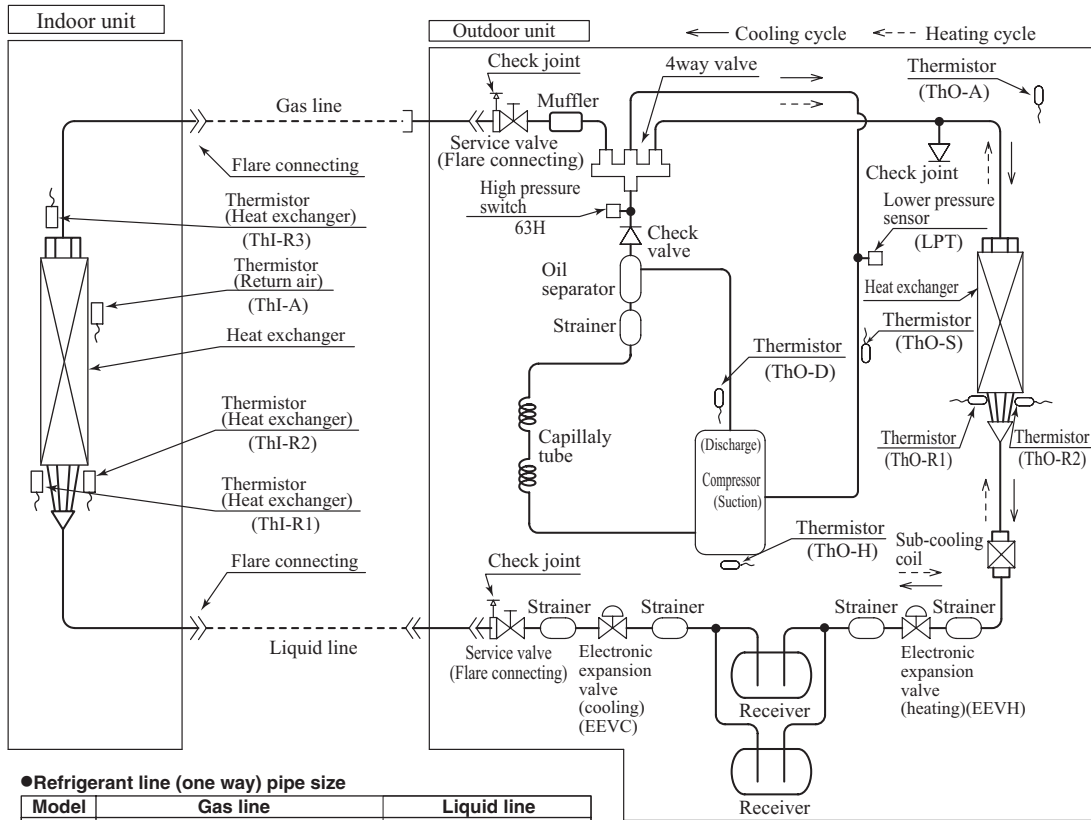

●Refrigerant line (one way) pipe size

Model	Gas line	Liquid line
FDC 200	In case of ø22.22 : 35m	In case of ø9.52 : 40m In case of ø12.7 : 70m
FDC 250	In case of ø25.4 or ø28.58 : 70m	In case of ø12.7 : 70m

(2) Twin type
Model FDC 71

Все каталоги и инструкции здесь: <http://splitoff.ru/tehn-doc.html>

⇌ - Heating cycle

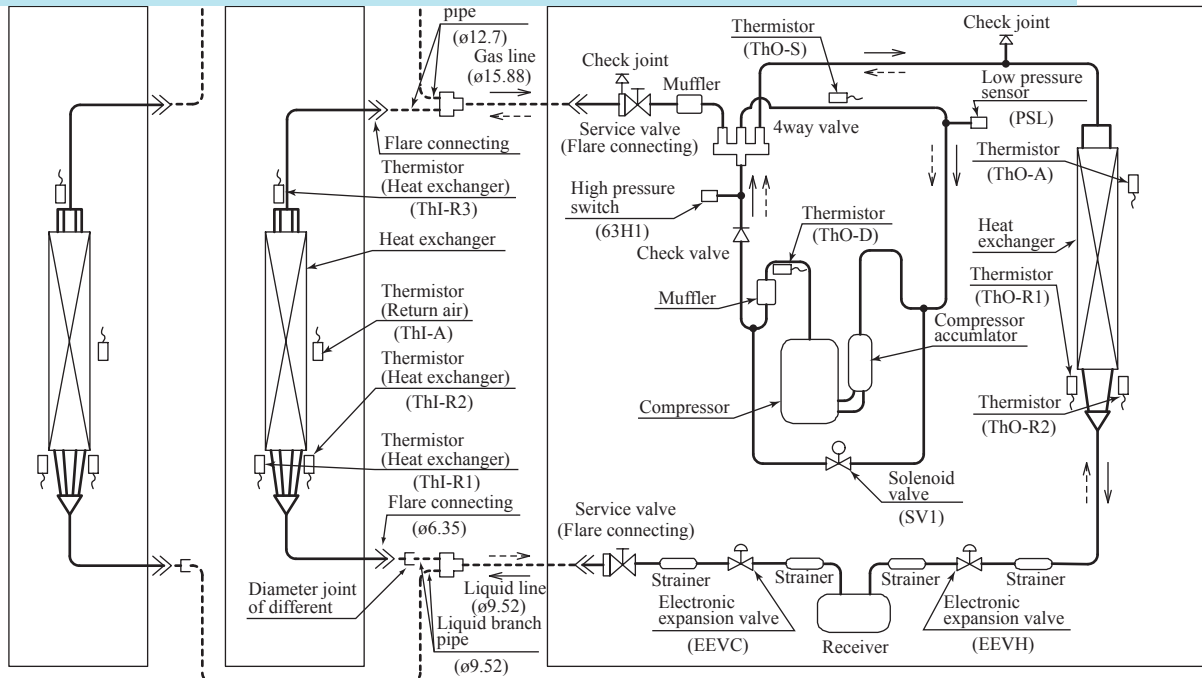

Models FDC 100, 125, 140

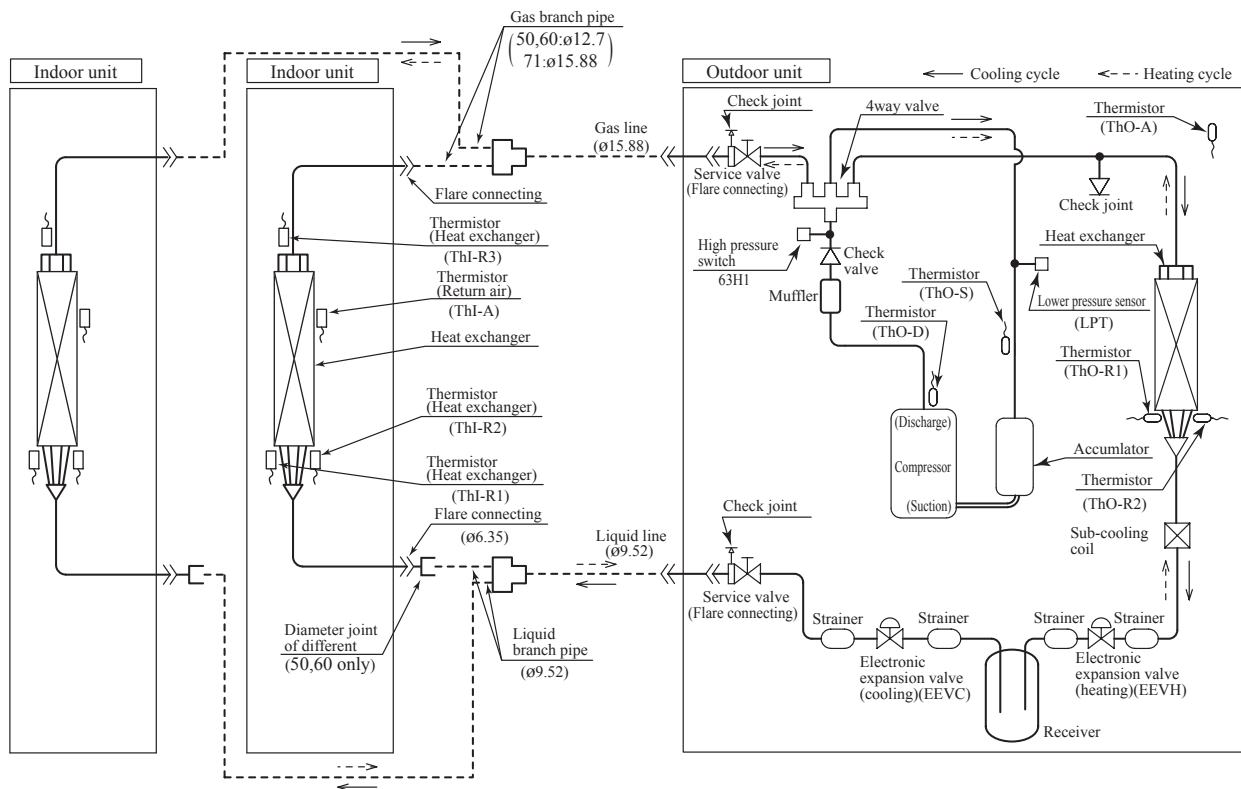

Models FDC 200, 250

Все каталоги и инструкции здесь: <http://splitoff.ru/tehn-doc.html>

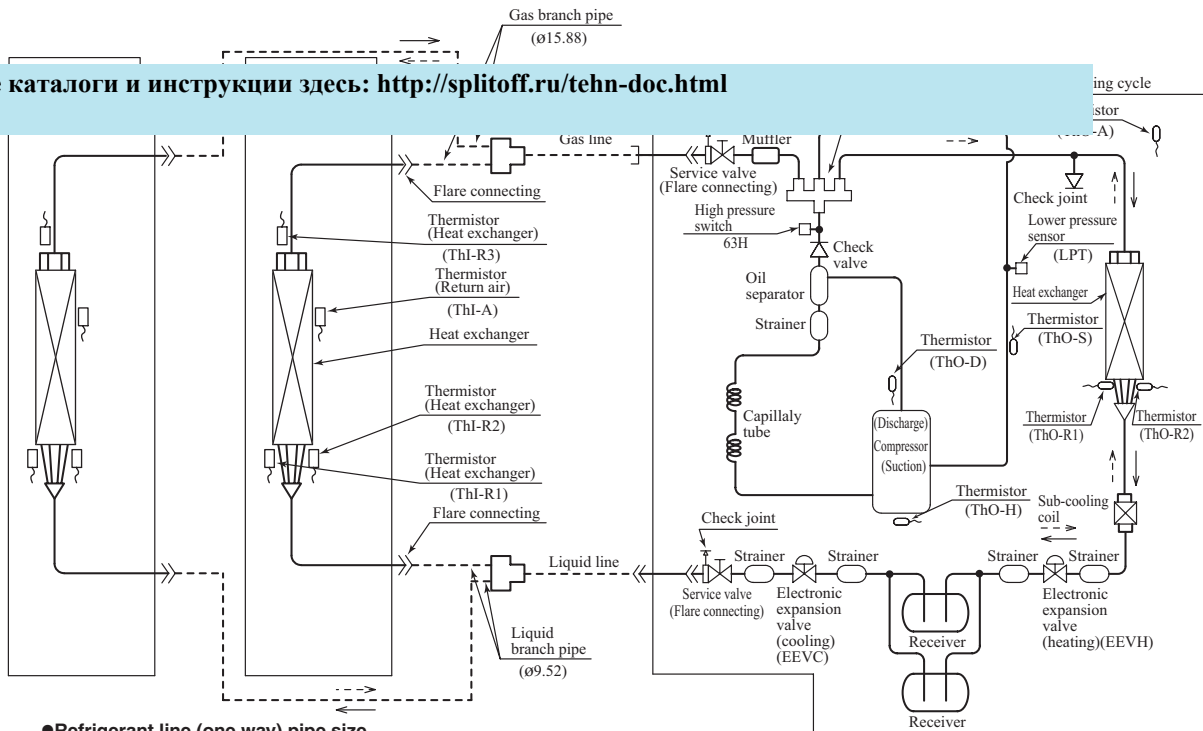

●Refrigerant line (one way) pipe size

Model	Gas line	Liquid line
FDC 200	In case of ø22.22 : 35m	In case of ø9.52 : 40m
	In case of ø25.4 or ø28.58 : 70m	In case of ø12.7 : 70m
FDC 250	In case of ø25.4 or ø28.58 : 70m	In case of ø12.7 : 70m

(3) Triple type

Model FDC 140

Все каталоги и инструкции здесь: <http://splitoff.ru/tehn-doc.html>

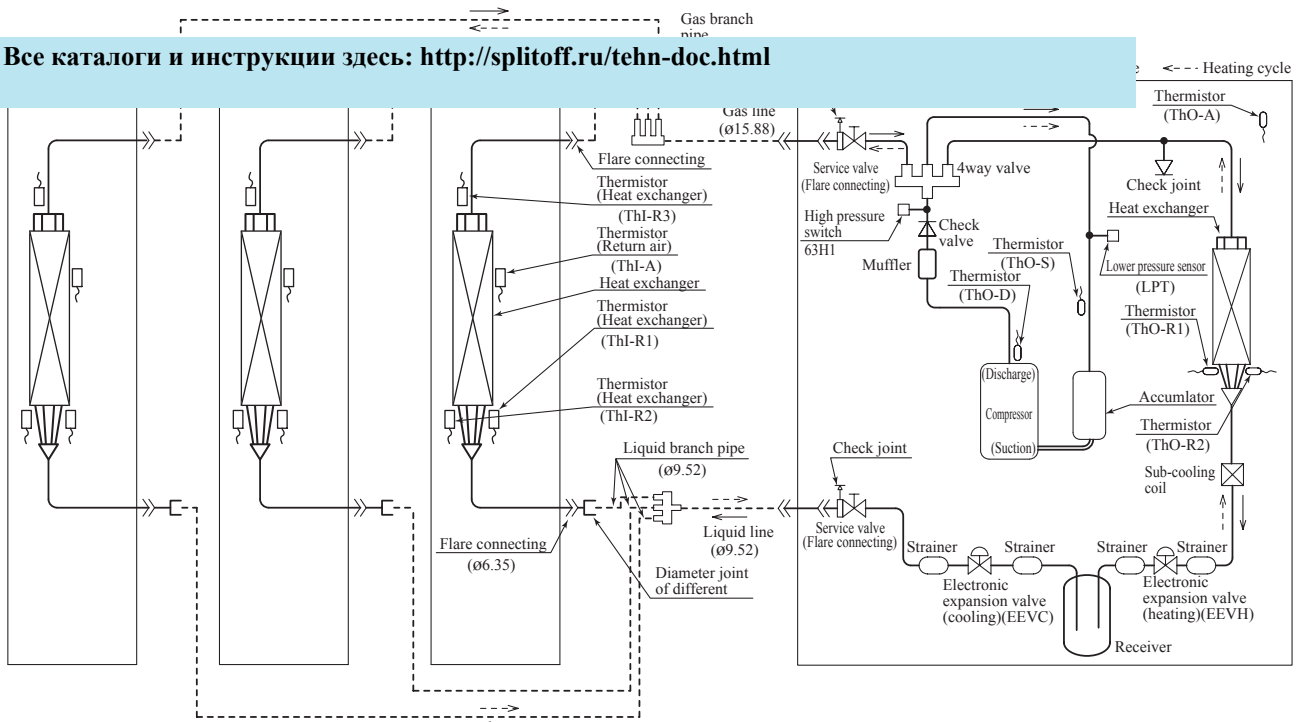

Model FDC 200

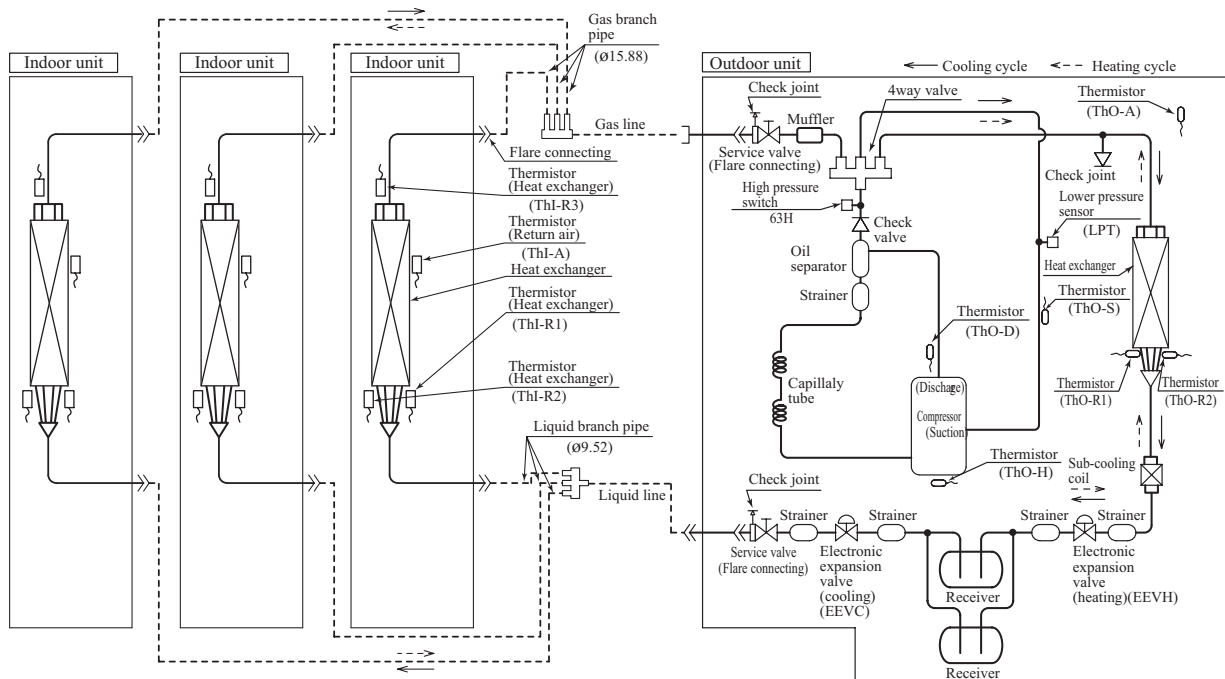

●Refrigerant line (one way) pipe size

Gas line	Liquid line
In case of ø22.22 : 35m	In case of ø9.52 : 40m
In case of ø25.4 or ø28.58 : 70m	In case of ø12.7 : 70m

(4) Double Twin type

Models FDC 200, 250

Все каталоги и инструкции здесь: <http://splitoff.ru/tehn-doc.html>

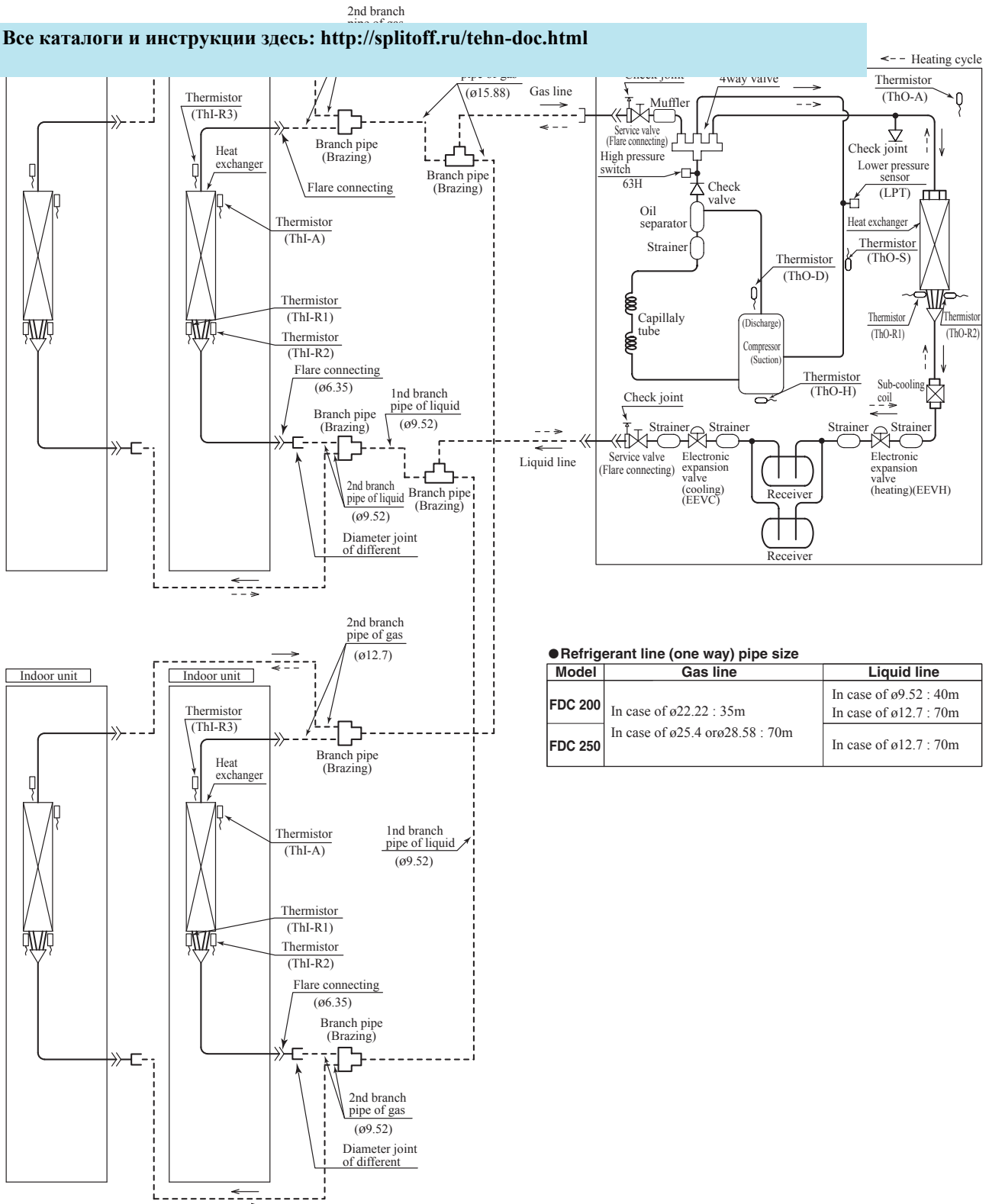

● Refrigerant line (one way) pipe size

Model	Gas line	Liquid line
FDC 200	In case of ø22.22 : 35m	In case of ø9.52 : 40m In case of ø12.7 : 70m
FDC 250	In case of ø25.4 or ø28.58 : 70m	In case of ø12.7 : 70m

Preset point of the protective devices

Parts name	Mark	Equipped unit	SRC 40, 50, 60 models	FDC 71, 100, 125, 140 models	FDC 200, 250 models
Все каталоги и инструкции здесь: http://splitoff.ru/tehn-doc.html					
loading in heating)	Thi-R	Indoor unit	OFF 1.0°C ON 10°C		
Thermistor (for frost prevention)					
Thermistor (for protection high pressure in cooling.)	Tho-R (TH1)	Outdoor unit	OFF 53°C ON 63°C	OFF 51°C ON 65°C	
Thermistor (for detecting discharge pipe temp.)	Tho-D (TH3)	Outdoor unit	OFF 115°C ON 95°C	OFF 115°C ON 85°C	OFF 135°C ON 90°C
High pressure switch (for protection)	63H1	Outdoor unit	—	OFF 4.15MPa ON 3.15MPa	
Low pressure sensor (for protection)	LPT	Outdoor unit	—	OFF 0.227MPa ON 0.079MPa	

5. APPLICATION DATA

(1) Installation of indoor unit

(a) Ceiling cassette-4way compact type (FDTC)

PJA012D786

Все каталоги и инструкции здесь: <http://splitoff.ru/tehn-doc.html>

(Outdoor) and refrigerant pipe work installation for outdoor unit, refer to the installation manual attached to an outdoor unit.
This unit must always be used with the panel.

SAFETY PRECAUTIONS

- Read the "SAFETY PRECAUTIONS" carefully first of all and then strictly follow it during the installation work in order to protect yourself.
- The precautionary items mentioned below are distinguished into two levels, [WARNING] and [CAUTION].
[WARNING]: Wrong installation would cause serious consequences such as injuries or death.
[CAUTION]: Wrong installation might cause serious consequences depending on circumstances.
Both mentions the important items to protect your health and safety so strictly follow them by any means.
- The meanings of "Marks" used here are as shown as follows:
⊗ Never do it under any circumstances. ● Always do it according to the instruction.
- After completing the installation, do commissioning to confirm there are no abnormalities, and explain to the customers about "SAFETY PRECAUTIONS", correct operation method and maintenance method (air filter cleaning, operation method and temperature setting method) with user's manual of this unit.
Ask your customers to keep this installation manual together with the user's manual. Also, ask them to hand over the user's manual to the new user when the owner is changed.

⚠ WARNING

- **Installation should be performed by the specialist.** (Warning icon)
If you install the unit by yourself, it may lead to serious trouble such as water leakage, electric shock, fire, and injury due to overturn of the unit.
- **Install the system correctly according to these installation manuals.** (Warning icon)
Improper installation may cause explosion, injury, water leakage, electric shock, and fire.
- **When installing in small rooms, take prevention measures not to exceed the density limit of refrigerant in the event of leakage, referred by the formula (accordance with ISO5149).** (Warning icon)
If the density of refrigerant exceeds the limit, please consult the dealer and install the ventilation system, otherwise lack of oxygen can occur, which can cause serious accidents.
- **Use the genuine accessories and the specified parts for installation.** (Warning icon)
If parts unspecified by our company are used it could cause water leakage, electric shock, fire, and injury due to overturn of the unit.
- **Ventilate the working area well in case the refrigerant leaks during installation.** (Warning icon)
If the refrigerant contacts the fire, toxic gas is produced.
- **Install the unit in a location that can hold heavy weight.** (Warning icon)
Improper installation may cause the unit to fall leading to accidents.
- **Install the unit properly in order to be able to withstand strong winds such as typhoons, and earthquakes.** (Warning icon)
Improper installation may cause the unit to fall leading to accidents.
- **Do not mix air in to the cooling cycle on installation or removal of the air conditioner.** (Prohibition icon)
If air is mixed in, the pressure in the cooling cycle will rise abnormally and may cause explosion and injuries.
- **Be sure to have the electrical wiring work done by qualified electrical installer, and use exclusive circuit.** (Warning icon)
Power source with insufficient capacity and improper work can cause electric shock and fire.
- **Use specified wire for electrical wiring, fasten the wiring to the terminal securely, and hold the cable securely in order not to apply unexpected stress on the terminal.** (Warning icon)
Loose connections or hold could result in abnormal heat generation or fire.
- **Arrange the electrical wires in the control box properly to prevent them from rising. Fit the lid of the services panel properly.** (Warning icon)
Improper fitting may cause abnormal heat and fire.
- **Check for refrigerant gas leakage after installation is completed.** (Warning icon)
If the refrigerant gas leaks into the house and comes in contact with a fan heater, a stove, or an oven, toxic gas is produced.
- **Use the specified pipe, flare nut, and tools for R410A.** (Warning icon)
Using existing parts (R22) could cause the unit failure and serious accident due to explosion of the cooling cycle.
- **Tighten the flare nut according to the specified method by with torque wrench.** (Warning icon)
If the flare nut were tightened with excess torque, it could cause burst and refrigerant leakage after a long period.
- **Do not put the drainage pipe directly into drainage channels where poisonous gases such as sulfide gas can occur.** (Prohibition icon)
Poisonous gases will flow into the room through drainage pipe and seriously affect the user's health and safety. This can also cause the corrosion of the indoor unit and a resultant unit failure or refrigerant leak.
- **Connect the pipes for refrigeration circuit securely in installation work before compressor is operated.** (Warning icon)
If the compressor is operated when the service valve is open without connecting the pipe, it could cause explosion and injuries due to abnormal high pressure in the system.
- **Stop the compressor before removing the pipe after shutting the service valve on pump down work.** (Warning icon)
If the pipe is removed when the compressor is in operation with the service valve open, air would be mixed in the refrigeration circuit and it could cause explosion and injuries due to abnormal high pressure in the cooling cycle.
- **Only use prescribed optional parts. The installation must be carried out by the qualified installer.** (Warning icon)
If you install the system by yourself, it can cause serious trouble such as water leaks, electric shocks, fire.
- **Do not repair by yourself. And consult with the dealer about repair.** (Prohibition icon)
Improper repair may cause water leakage, electric shock or fire.
- **Consult the dealer or a specialist about removal of the air conditioner.** (Warning icon)
Improper installation may cause water leakage, electric shock or fire.
- **Turn off the power source during servicing or inspection work.** (Warning icon)
If the power is supplied during servicing or inspection work, it could cause electric shock and injury by the operating fan.
- **Do not run the unit when the panel or protection guard are taken off.** (Prohibition icon)
Touching the rotating equipment, hot surface, or high voltage section could cause an injury to be caught in the machine, to get burned, or electric shock.
- **Shut off the power before electrical wiring work.** (Warning icon)
It could cause electric shock, unit failure and improper running.

- Do not connect the earth wiring to the gas pipe, water pipe, lightning rod and telephone earth wiring. Improper earth could cause unit failure and electric shock due to a short circuit. (Warning icon)
- **Earth leakage breaker must be installed.** (Warning icon)
If the earth leakage breaker is not installed, it can cause electric shocks.
- **Use the circuit breaker of correct capacity. Circuit breaker should be the one that disconnect all poles under over current.** (Warning icon)
Using the incorrect one could cause the system failure and fire.
- **Do not use any materials other than a fuse of correct capacity where a fuse should be used.** (Prohibition icon)
Connecting the circuit by wire or copper wire could cause unit failure and fire.
- **Do not install the indoor unit near the location where there is possibility of flammable gas leakages.** (Prohibition icon)
If the gas leaks and gathers around the unit, it could cause fire.
- **Do not install and use the unit where corrosive gas (such as sulfurous acid gas etc.) or flammable gas (such as thinner, petroleum etc.) may be generated or accumulated, or volatile flammable substances are handled.** (Prohibition icon)
It could cause the corrosion of heat exchanger, breakage of plastic parts etc. And inflammable gas could cause fire.
- **Secure a space for installation, inspection and maintenance specified in the manual.** (Warning icon)
Insufficient space can result in accident such as personal injury due to falling from the installation place.
- **Do not use the indoor unit at the place where water splashes such as laundry.** (Prohibition icon)
Indoor unit is not waterproof. It could cause electric shock and fire.
- **Do not use the indoor unit for a special purpose such as food storage, cooling for precision instrument, preservation of animals, plants, and a work of art.** (Prohibition icon)
It could cause the damage of the items.
- **Do not install nor use the system near equipments which generate electromagnetic wave or high harmonics.** (Prohibition icon)
Equipments like inverter equipment, private power generator, high-frequency medical equipment, or telecommunication equipment might influence the air conditioner and cause a malfunction and breakdown. Or the air conditioner might influence medical equipments or telecommunication equipments, and obstruct their medical activity or cause jamming.
- **Do not install the remote controller at the direct sunlight.** (Prohibition icon)
It could cause breakdown or deformation of the remote controller.
- **Do not install the indoor unit at the place listed below.** (Prohibition icon)
 - Places where flammable gas could leak.
 - Places where carbon fiber, metal powder or any powder is floated.
 - Place where the substances which affect the air conditioner are generated such as sulfide gas, chloride gas, acid, alkali or ammoniac atmospheres.
 - Places exposed to oil mist or steam directly.
 - On vehicles and ships
 - Places where machinery which generates high harmonics is used.
 - Places where cosmetics or special sprays are frequently used.
 - Highly salted area such as beach.
 - Heavy snow area
 - Places where the system is affected by smoke from a chimney.
 - Altitude over 1000m
- **Do not install the indoor unit in the locations listed below (Be sure to install the indoor unit according to the installation manual for each model because each indoor unit has each limitation)** (Prohibition icon)
 - Locations with any obstacles which can prevent inlet and outlet air of the unit.
 - Locations where vibration can be amplified due to insufficient strength of structure.
 - Locations where the infrared receiver is exposed to the direct sunlight or the strong light beam. (in case of the infrared specification unit)
 - Locations where an equipment affected by high harmonics is placed. (TV set or radio receiver is placed within 5m)
 - Locations where drainage cannot run off safely.
 It can affect performance or function and etc..
- **Do not put any valuables which will break down by getting wet under the air conditioner.** (Prohibition icon)
Condensation could drop when the relative humidity is higher than 80% or drain pipe is clogged, and it damages user's belongings.
- **Do not use the base frame for the outdoor unit which is corroded or damaged after a long period of use.** (Prohibition icon)
It could cause the unit falling down and injury.
- **Pay attention not to damage the drain pan by weld sputter when brazing work is done near the unit.** (Warning icon)
If sputter entered into the unit during brazing work, it could cause damage (pinhole) of drain pan and leakage of water. To avoid damaging, keep the indoor unit packed or cover the indoor unit.
- **Install the drain pipe to drain the water surely according to the installation manual.** (Warning icon)
Improper connection of the drain pipe may cause dropping water into room and damaging user's belongings.
- **Do not share the drain pipe for indoor unit and GHP (Gas Heat Pump system) outdoor unit.** (Prohibition icon)
Toxic exhaust gas would flow into room and it might cause serious damage (some poisoning or deficiency of oxygen) to user's health and safety.
- **Be sure to perform air tightness test by pressurizing with nitrogen gas after completed refrigerant piping work.** (Warning icon)
If the density of refrigerant exceeds the limit in the event of refrigerant leakage in the small room, lack of oxygen can occur, which can cause serious accidents.
- **For drain pipe installation, be sure to make descending slope of greater than 1/100, not to make traps, and not to make air-bleeding.** (Warning icon)
Check if the drainage is correctly done during commissioning and ensure the space for inspection and maintenance.
- **Ensure the insulation on the pipes for refrigeration circuit so as not to condense water.** (Warning icon)
Incomplete insulation could cause condensation and it would wet ceiling, floor, and any other valuables.
- **Do not install the outdoor unit where is likely to be a nest for insects and small animals.** (Prohibition icon)
Insects and small animals could come into the electronic components and cause breakdown and fire. Instruct the user to keep the surroundings clean.
- **Pay extra attention, carrying the unit by hand.** (Warning icon)
Carry the unit with 2 people if it is heavier than 20kg. Do not use the plastic straps but the grabbing place, moving the unit by hand. Use protective gloves in order to avoid injury by the aluminum fin.
- **Make sure to dispose of the packaging material.** (Warning icon)
Leaving the materials may cause injury as metals like nail and woods are used in the package.
- **Do not operate the system without the air filter.** (Prohibition icon)
It may cause the breakdown of the system due to clogging of the heat exchanger.
- **Do not touch any button with wet hands.** (Prohibition icon)
It could cause electric shock.
- **Do not touch the refrigerant piping with bare hands when in operation.** (Prohibition icon)
The pipe during operation would become very hot or cold according to the operating condition, and it could cause a burn or frostbite.
- **Do not clean up the air conditioner with water.** (Prohibition icon)
It could cause electric shock.
- **Do not turn off the power source immediately after stopping the operation.** (Prohibition icon)
Be sure to wait for more than 5 minutes. Otherwise it could cause water leakage or breakdown.
- **Do not control the operation with the circuit breaker.** (Prohibition icon)
It could cause fire or water leakage. In addition, the fan may start operation unexpectedly and it may cause injury.

① Before installation

- Install correctly according to the installation manual.
- Confirm the following points:
 - Unit type/Power supply specification
 - Pipes/Wires/Small parts
 - Accessory items

Accessory items

8	4	1	1	4	1	1	1	1
For unit hanging	For adjustment in hanging in the unit's main body	For heat insulation of gas pipe	For heat insulation of liquid tube	For pipe cover fixing	For heat insulation of drain socket	For heat insulation of drain socket	For drain pipe connecting	For drain hose mounting

② Selection of installation location for the indoor unit

- Select the suitable areas to install the unit under approval of the user.
 - Areas where the indoor unit can deliver hot and cold wind sufficiently. Suggest to the user to use a circulator if the ceiling height is over 3m to avoid warm air being accumulated on the ceiling.
 - Areas where there is enough space to install and service.
 - Areas where it can be drained properly. Areas where drain pipe descending slope can be taken.
 - Areas where there is no obstruction of airflow on both air return grille and air supply port.
 - Areas where fire alarm will not be accidentally activated by the air conditioner.
 - Areas where the supply air does not short-circuit.
 - Areas where it is not influenced by draft air.
 - Areas not exposed to direct sunlight.
 - Areas where dew point is lower than around 28°C and relative humidity is lower than 80%.
 (This indoor unit is tested under the condition of JIS (Japan Industrial Standard) high humidity condition and confirmed there is no problem. However, there is some risk of condensation drop if the air conditioner is operated under the severer condition than mentioned above.
 If there is a possibility to use it under such a condition, attach additional insulation of 10 to 20mm thick for entire surface of indoor unit, refrigeration pipe and drain pipe.)
 - Areas where TV and radio stays away more than 1m. (It could cause jamming and noise.)
 - Areas where any items which will be damaged by getting wet are not placed such as food, table wares, server, or medical equipment under the unit.
 - Areas where there is no influence by the heat which cookware generates.
 - Areas where not exposed to oil mist, powder and/or steam directly such as above fryer.
 - Areas where lighting device such as fluorescent light or incandescent light doesn't affect the operation.
 (A beam from lighting device sometimes affects the infrared receiver for the wireless remote controller and the air conditioner might not work properly.)
- Check if the place where the air conditioner is installed can hold the weight of the unit. If it is not able to hold, reinforce the structure with boards and beams strong enough to hold it. If the strength is not enough, it could cause injury due to unit falling.
- If there are 2 units of wireless type, keep them away for more than 5m to avoid malfunction due to cross communication.
- When plural indoor units are installed nearby, keep them away for more than 4m.

Space for installation and service

- When it is not possible to keep enough space between indoor unit and wall or between indoor units, close the air supply port where it is not possible to keep space and confirm there is no short circuit of airflow.
- Install the indoor unit at a height of more than 2.5m above the floor.

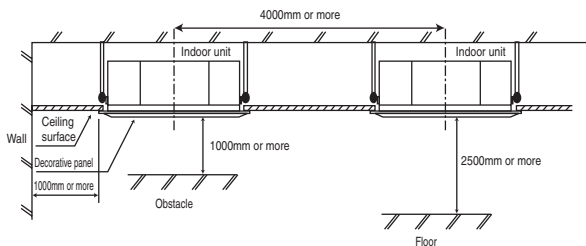

③ Preparation before installation

- If suspension bolt becomes longer, do reinforcement of earthquake resistant.
 - For grid ceiling
 - When suspension bolt length is over 500mm, or the gap between the ceiling and roof is over 700mm, apply earthquake resistant brace to the bolt.
 - In case the unit is hanged directly from the slab and is installed on the ceiling plane which has

stant brace to the bolt on site.

Ceiling opening, Suspension bolts pitch, Pipe position

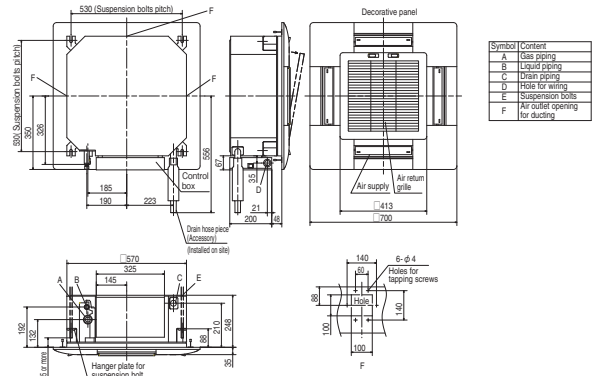

④ Installation of indoor unit

Work procedure

- This units is designed for 2 x 2 grid ceiling. If necessary, please detach the T bar temporarily before you install it. If it is installed on a ceiling other than 2 x 2 grid ceiling, provide an inspection port on the control box side.
- Arrange the suspension bolt at the right position (530mmx530mm).
- Make sure to use four suspension bolts and fix them so as to be able to hold 500N load.
- Ensure that the lower end of the suspension bolt should be 45mm above the ceiling plane. Temporarily put the four lower nuts 88mm above the ceiling plane and the upper nuts on distant place from the lower nuts in order not to obstruct hanging the indoor unit or adjust the indoor unit position, and then hang the indoor unit.

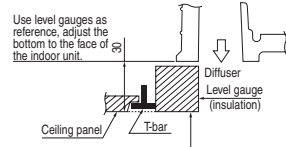
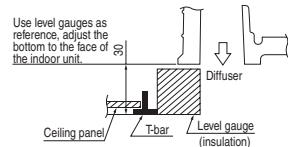
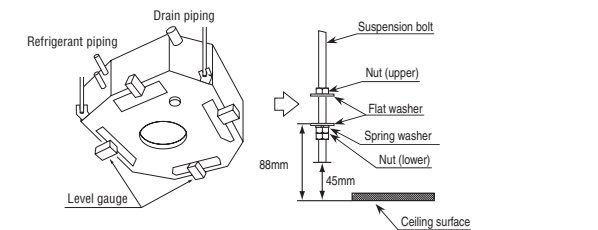
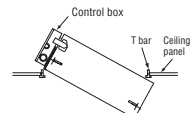

When the ceiling panel comes below the T bar, align the bottom of the level gauge to the lower face of the ceiling panel.

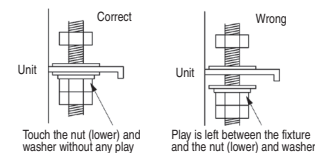

④ Installation of indoor unit (continued)

6. Make sure to install the indoor unit horizontally. Confirm the levelness of the indoor unit with a level gauge or transparent hose filled with water. Keep the height difference at both ends of the indoor unit within 3mm.
7. Tighten four upper nuts and fix the unit after height and levelness

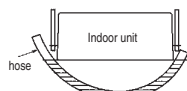

Все каталоги и инструкции здесь: <http://splitoff.ru/tehn-doc.html>

- Do not adjust the height by adjusting upper nuts. It will cause unexpected stress on the indoor unit and it will lead to deformation of the unit, failure of attaching a panel, and generating noise from the fan.
- Make sure to install the indoor unit horizontally and set the gap between the unit underside and the ceiling plane properly. Improper installation may cause air leakage, dew condensation, water leakage and noise.
- Even after decorative panel attached, still the unit height can be adjusted finely. Refer to the installation manual for decorative panel for details.
- Make sure there is no gap between decoration panel and ceiling surface, and between decoration panel and the indoor unit. The gap may cause air leakage, dew condensation and water leakage.
- In case decorative panel is not installed at the same time, or ceiling material is installed after the unit installed, put the cardboard template for installation attached on the package (packing material of cardboard box) on the bottom of the unit in order to avoid dust coming into the indoor unit.

⑤ Refrigerant pipe

Caution

- Use the new refrigerant pipe. When re-using the existing pipe system for R22 or R407C, pay attention to the following items.
 - Change the flare nuts with the attached ones (JIS category 2), and reprocess the flare parts.
 - Do not use thin-walled pipes.
- Use phosphorus deoxidized copper alloy seamless pipe (C1220T specified in JIS H3300) for refrigeration pipe installation. In addition, make sure there is no damage both inside and outside of the pipe, and no harmful substances such as sulfur, oxide, dust or a contaminant stuck on the pipes.
- Do not use any refrigerant other than R410A. Using other refrigerant except R410A (R22 etc.) may degrade inside refrigeration oil. And air getting into refrigeration circuit may cause over-pressure and resultant it may result in bursting, etc.
- Store the copper pipes indoors and seal the both end of them until they are brazed in order to avoid any dust, dirt or water getting into pipe. Otherwise it will cause degradation of refrigeration oil and compressor breakdown, etc.
- Use special tools for R410 refrigerant.

Work procedure

1. Remove the flare nut and blind flanges on the pipe of the indoor unit.
 - Make sure to loosen the flare nut with holding the nut on pipe side with a spanner and giving torque to the nut with another spanner in order to avoid unexpected stress to the copper pipe, and then remove them. (Gas may come out at this time, but it is not abnormal.)
 - Pay attention whether the flare nut pops out. (as the indoor unit is sometimes pressured.)
2. Make a flare on liquid pipe and gas pipe, and connect the refrigeration pipes on the indoor unit.
 - Bend the pipe with as big radius as possible and do not bend the pipe repeatedly. In addition, do not twist and crush the pipes.
 - Do a flare connection as follows:
 - Make sure to loosen the flare nut with holding the nut on pipe side with a spanner and giving torque to the nut with another spanner in order to avoid unexpected stress to the copper pipe, and then remove them.
 - When fastening the flare nut, align the refrigeration pipe with the center of flare nut, screw the nut for 3-4 times by hand and then tighten it by spanner with the specified torque mentioned in the table below. Make sure to hold the pipe on the indoor unit securely by a spanner when tightening the nut in order to avoid unexpected stress on the copper pipe.
3. Cover the flare connection part of the indoor unit with attached insulation material after a gas leakage inspection, and tighten both ends with attached straps.
 - Make sure to insulate both gas pipes and liquid pipes completely.
 - Incomplete insulation may cause dew condensation or water dropping.
4. Refrigerant is charged in the outdoor unit. As for the additional refrigerant charge for the indoor unit and piping, refer to the installation manual attached to the outdoor unit.

Pipe diameter	Tightening torque N·m
φ 6.35	14 to 18
φ 9.52	34 to 42
φ 12.7	49 to 61
φ 15.88	68 to 82
φ 19.05	100 to 120

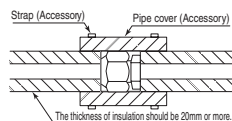

⑥ Drain pipe (continued)

Work procedure

1. Make sure to insert the drain hose (the end made of soft PVC) to the end of the step part of drain socket. Attach the hose clamp to the drain hose around 10mm from the end, and fasten the screw within 5mm left to the nut.

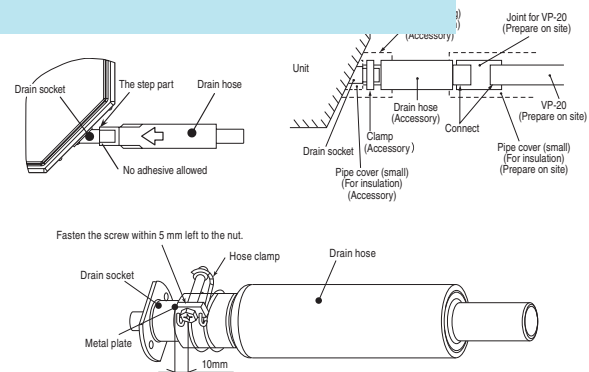

2. Prepare a joint for connecting VP-20 pipe, adhere and connect the joint to the drain hose (the end made of rigid PVC), and adhere and connect VP-20 pipe (prepare on site).
 - As for drain pipe, apply VP-20 made of rigid PVC which is on the market.
 - Make sure that the adhesive will not get into the supplied drain hose. It may cause the flexible part broken after the adhesive is dried up and gets rigid.
 - Do not bend or make an excess offset on the drain hose as shown in the picture. Bend or excess offset will cause drain leakage.

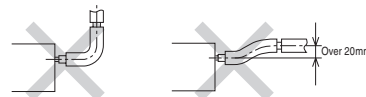

3. Make sure to make descending slope of greater than 1/100 and do not make up-down bend and/or trap in the midway.
 - Pay attention not to give stress on the pipe on the indoor unit side, and support and fix the pipe as close place to the unit as possible when connecting the drain pipe.
 - Do not set up air vent.

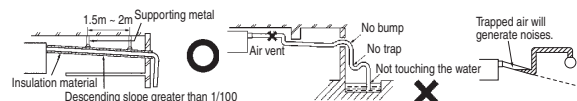

- When sharing a drain pipe for more than one unit, lay the main pipe 100mm below the drain outlet of the unit. In addition, select VP-30 or bigger size for main drain pipe.
4. Insulate the drain pipe.
 - Be sure to insulate the drain socket and rigid PVC pipe installed indoors otherwise it may cause dew condensation and water leakage.
 - After drainage test implementation, cover the drain socket part with pipe cover (small size), then use the pipe cover (big size) to cover the pipe cover (small size), clamps and part of the drain hose, and fix and wrap it with tapes to wrap and make joint part gapless.

Drain up

- The position for drain pipe outlet can be raised up to 600mm above the ceiling. Use elbows for installation to avoid obstacles inside ceiling. If the horizontal drain pipe is too long before vertical pipe, the backflow of water will increase when the unit is stopped, and it may cause overflow of water from the drain pan on the indoor unit. In order to avoid overflow, keep the horizontal pipe length and offset of the pipe within the limit shown in the figure below.

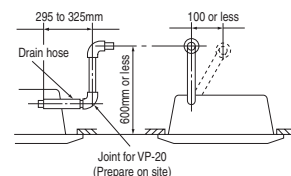

⑥ Drain pipe

Caution

- Install the drain pipe according to the installation manual in order to drain properly. Imperfection in draining may cause flood indoors and wetting the household goods etc.
- Do not put the drain pipe directly into the ditch where toxic gas such as sulfur, the other harmful and inflammable gas is generated. Toxic gas would flow into the room and it would cause serious damage to user's health and safety (some poisoning or deficiency of oxygen). In addition, it may cause corrosion of heat exchanger and bad smell.
- Connect the pipe securely to avoid water leakage from the joint.
- Insulate the pipe properly to avoid condensation drop.
- Check if the water can flow out properly from both the drain outlet on the indoor unit and the end of the drain pipe after installation.
- Make sure to make descending slope of greater than 1/100 and do not make up-down bend and/or trap in the midway. In addition, do not put air vent on the drain pipe. Check if water is drained out properly from the pipe during commissioning. Also, keep sufficient space for inspection and maintenance.

⑥ Drain pipe (continued)

Drain test

- After installation of drain pipe, make sure that drain system work in good condition and no water leakage from joint and drain pan. Check if the motor sound of drain pump is normal or not.
- Do drain test even if installation of heating season.
- For new building cases, make sure to complete the test before

2. make sure that water is drained out properly and there is no water leakage from any joints of the drain pipe at the test. Confirm that the water is properly drained out while the drain motor is operating. At the drain socket (transparent), it is possible to check if the water is drained out properly.
3. Unplug the drain plug on the indoor unit to remove remaining water on the drain pan after the test, and re-plug it. And insulate the drain pipe properly finally.

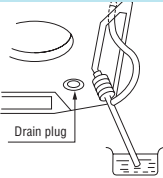

Drain pump operation

- In case electrical wiring work finished
Drain pump can be operated by remote controller (wired).
For the operation method, refer to [Operation for drain pump] in the installation manual for wiring work.
- In case electrical wiring work not finished
Drain pump will run continuously when the dip switch "SW7-1" on the indoor unit PCB is turned ON, the Connector CNB is disconnected, and then the power supply (220-240VAC on the terminal block [① and ②] or [L and N]) is turned ON.
Make sure to turn OFF "SW7-1" and reconnect the Connector CNB after the test.

⑦ Wiring-out position and wiring connection

- Electrical installation work must be performed according to the installation manual by an electrical installation service provider qualified by a power provider of the country, and be executed according to the technical standards and other regulations applicable to electrical installation in the country. Be sure to use an exclusive circuit.
- Use specified cord, fasten the wiring to the terminal securely, and hold the cord securely in order not to apply unexpected stress on the terminal.
- Do not put both power source line and signal line on the same route. It may cause miscommunication and malfunction.
- Be sure to do D type earth work.
- For the details of electrical wiring work, see attached instruction manual for electrical wiring work.

1. Remove a lid of the control box (1 screws).
2. Hold each wiring inside the unit and fasten them to terminal block securely.
3. Fix the wiring with clamp.
4. Install a lid of the control box back to original place.

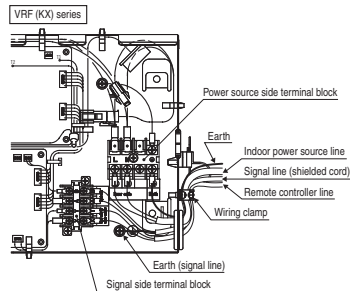
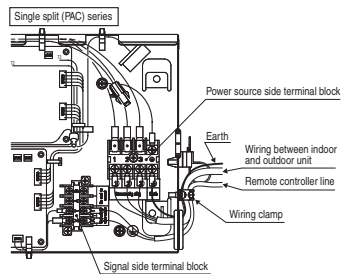

⑧ Panel installation

- After wiring work finished, install the panel on the indoor unit.
- Refer to attached panel installation manual for details.

Accessory items

3	Bolt		4 pieces	For installing the panel
4	Screw		1 piece	For attaching a hook
5	Screw		2 pieces	For attaching a chain

- Attach the panel on the indoor unit after electrical wiring work.
- Refer to attached manual for panel installation for details. (See next page)

⑨ Check list after installation

- Check the following items after all installation work completed.

Check if	Expected trouble	Check
The indoor and outdoor units are fixed securely?	Falling, vibration, noise	
Inspection for leakage is done?	Insufficient capacity	
Insulation work is properly done?	Water leakage	
Water is drained properly?	Water leakage	
Supply voltage is same as mentioned in the model name plate?	PCB burnt out, not working at all	
There is mis-wiring or mis-connection of piping?	PCB burnt out, not working at all	
Earth wiring is connected properly?	Electric shock	
Cable size comply with specified size?	PCB burnt out, not working at all	
Any obstacle blocks airflow on air inlet and outlet?	Insufficient capacity	

Все каталоги и инструкции здесь: <http://splitoff.ru/tehn-doc.html>

PANEL INSTALLATION MANUAL

PJA012D783

Please read this manual together with the indoor unit's installation manual.

WARNING

Все каталоги и инструкции здесь: <http://splitoff.ru/tehn-doc.html>

- Make sure the power supply is turned off when electric wiring work. Otherwise, electric shock, malfunction and improper running may occur.



① Checking the indoor unit installation position

- Read this manual together with the air conditioner installation manual carefully.
- Check if the gap between the ceiling plane and the indoor unit is correct by inserting the level gauge into the air outlet port of the indoor unit. (See below drawing)
- Adjust the installation elevation if necessary.
- Remove the level gauge before you attach the panel.

Use level gauges as reference, adjust the bottom to the face of the indoor unit.

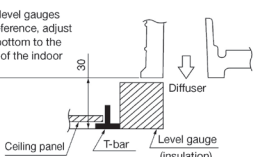

Use level gauges as reference, adjust the bottom to the face of the indoor unit.

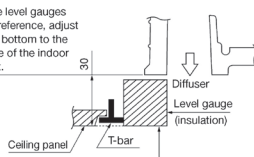

When the ceiling panel comes below the T-bar, align the bottom of the level gauge to the lower face of the ceiling panel.

② Orientation of the panel and return air grille installation

1. Take note that there is an orientation to install the panel.
 - Attach the panel with the orientation shown on the below.
 - Align the "PIPE SIDE" mark (on the panel) with the refrigerant pipes on the indoor unit.
2. The intake grille can also be attached in a rotated position by 90 degrees.

Caution

- In case the orientation of the panel is not correct, it will lead to air leakage and also it is not possible to connect the louver motor wiring.

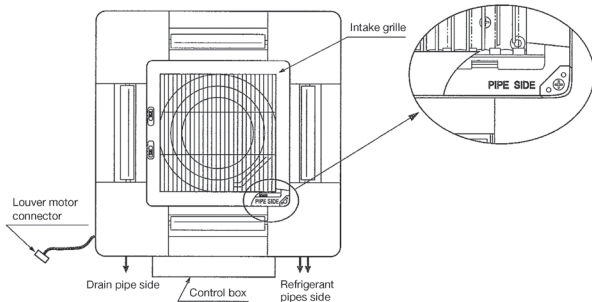

③ Removing a corner panel

- Unscrew the screw from the corner area, pull the corner panel toward the direction indicated by the arrow mark.

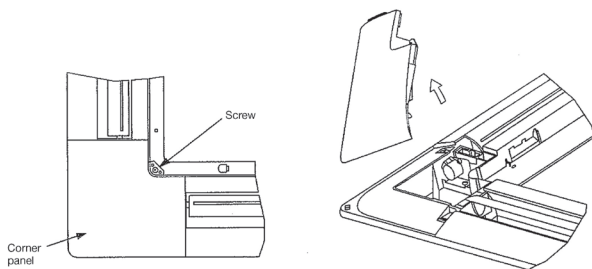

hooks and tighten the screw.

panel, engage two

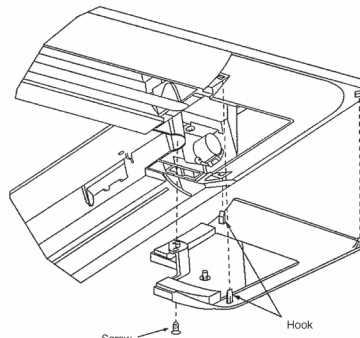

⑤ Panel installation

- Install the panel on the unit after completing the electrical wiring.

Accessories

1	Hook		1 piece	For fixing temporarily
2	Chain		2 pieces	
3	Screw		4 pieces	For hoisting the panel
4	Screw		1 piece	For attaching a hook
5	Screw		2 pieces	For attaching a chain

1. Screw in two bolts out of the four supplied with the panel by about slightly less than 5mm. (● mark (A) (B)) [Figure 1]

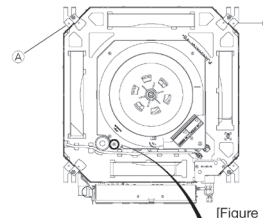

2. Attach the hook supplied with the panel to the main body with the hook fixing screw (1 screw). [Figure 2]

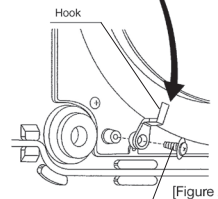

3. Open the intake grille.
4. Please remove the screw of a corner panel and remove a corner panel. (four places)

5. A panel is hooked on two bolts (● mark (A) (B)). [Figure 3]

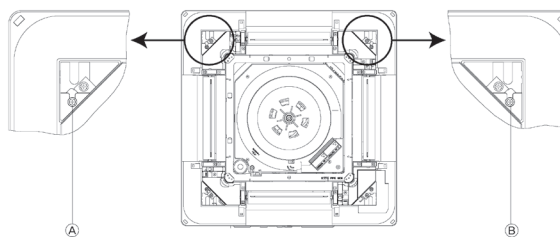

6. Please rotate a hook, put in the slot on the panel, and carry out fixing the panel temporarily. [Figure 4]



[Figure 4]

7. Tighten the two bolts used for fixing the panel temporarily and the other two.

Caution

- Improperly tightened hanging bolts can cause the problems listed below, so make sure that you have tightened them securely.
- If there is a gap remaining between the ceiling and the decorative panel even after the hanging bolts are tightened, adjust the installation level of the indoor unit again.



8. Please open the lid of a control box.
 9. Like drain pump wiring, please band together by the clamp and put in louver motor wiring into a control box. [Figure 5]
 10. Please connect a louver motor connector. [Figure 5]

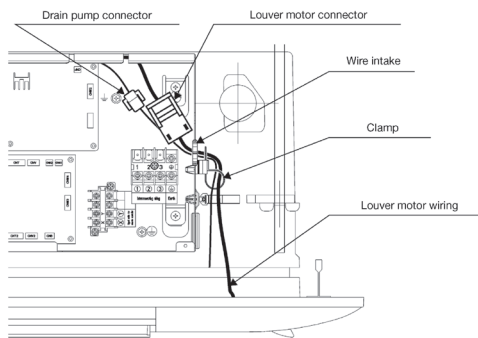

[Figure 5]

11. Attach two chains to the intake grille with two screws. [Figure 6]

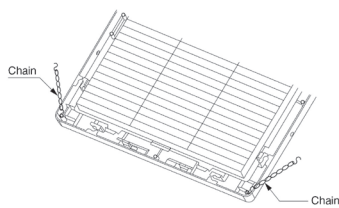

[Figure 6]

12. Replace the corner panels. Please also close a chain with a screw together then. [Figure 7]
 13. Close the intake grill.

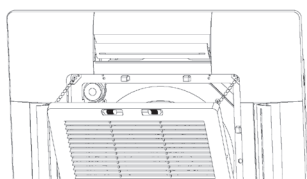

[Figure 7]

Caution

Make sure there is no stress given on the panel when adjusting the height of the indoor unit to avoid unexpected distortion. It may cause the distortion of panel or failing to close the air return grille.

⑦ How to set the airflow direction *1

It is possible to change the movable range of the louver on the air outlet from the wired remote controller. Once the top and bottom position is set, the louver will swing within the range between the top and the bottom when swing operation is chosen. It is also possible to apply different setting to each louver.

1 Stop the air conditioner and press **SET button and **LOUVER** button simultaneously for three seconds or more.**

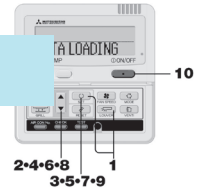

remote controller are more than one

*b+ SELECT 1/4
 1/0000 Δ

2 Press **▲ or **▼** button. (selection of indoor unit)**

Select the indoor unit of which the louver is set.
[EXAMPLE]
 1/0000 Δ → *1/0001 Δ* → *1/0002 Δ* → *1/0003 Δ*

3 Press **SET button. (determination of indoor unit)**

Selected indoor unit is fixed.
[EXAMPLE]
 1/0001 Δ (displayed for two seconds)
 ↓
 DATA LOADING Δ

NOTICE

In case the louver No to be set is uncertain, set any louver temporarily. The louver will swing once when the setting is completed and it is possible to confirm the louver No and the position. After that, choose the correct louver No and set the top and bottom position.

4 Press **▲ or **▼** button. (selection of louver No.)**

Select the louver No. to be set according to the right figure.
[EXAMPLE]
 No.1 Δ → *No.2 Δ* → *No.3 Δ* → *No.4 Δ*

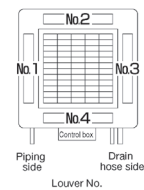

5 Press **SET button. (Determination of louver No.)**

The louver No. to be set is confirmed and the display shows the upper limit of the movable range.
[EXAMPLE] If No. 1 louver is selected
 No.1 UPPER2 Δ → current upper limit position

6 Press **▲ or **▼** button. (selection of upper limit position)**

Select the upper limit of louver movable range. "position 1" is the most horizontal, and "position 6" is the most downwards. "position --" is to return to the factory setting. If you need to change the setting to the default setting, use "position --".
 No.1 UPPER1 Δ (the most horizontal)
 No.1 UPPER2 Δ (horizontal)
 No.1 UPPER3 Δ
 No.1 UPPER4 Δ
 No.1 UPPER5 Δ (the most downwards)
 No.1 UPPER6 Δ (return to the default setting)

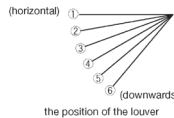

7 Press **SET button. (i in of the upper limit position)**

The upper limit position is fixed and the setting position is displayed for two seconds. Then proceed to lower limit position selection display.
[EXAMPLE]
 No.1 UPPER2 Δ (displayed for two seconds)
 ↓
 No.1 LOWER5 Δ (shows current setting)

8 Press **▲ or **▼** button. (Selection of lower limit position)**

Select the lower limit position of louver. "position 1" is the most horizontal, and "position 6" is the most downwards. "position --" is to return to the factory setting. If you need to change the setting to the default setting, use "position --".
 No.1 LOWER1 Δ (the most horizontal)
 No.1 LOWER2 Δ (horizontal)
 No.1 LOWER3 Δ
 No.1 LOWER4 Δ
 No.1 LOWER5 Δ (the most downwards)
 No.1 LOWER6 Δ (return to the default setting)

9 Press **SET button. (i in of the lower limit position)**

Upper limit position and lower limit position are fixed, and the set positions are displayed for two seconds, then setting is completed. After the setting is completed, the louver which was set moves from the original position to the lower limit position, and goes back to the original position again. (This operation is not performed if the indoor unit and/or indoor unit fan is in operation.)
[EXAMPLE]
 No.1 U2 L6 Δ (displayed for two seconds)
 SET COMPLETE
 No.1 Δ

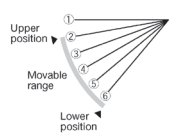

10 Press **ON/OFF button.**

Louver adjusting mode ends and returns to the original display. *2

Caution

If the upper limit position number and the lower limit position number are set to the same position, the louver is fixed at that position auto swing does not function.

ATTENTION

If you press **RESET** button during settings, the display will return to previous display. If you press **ON/OFF** button during settings, the mode will be ended and return to original display, and the settings that have not been completed will become invalid.

When plural remote controllers are connected, louver setting operation cannot be set by slave remote controller.

If it is necessary to fix the louver position manually, follow the procedure mentioned below.

- Shut off the main power switch.
- Unplug the connector of the louver motor which you want to fix the position. Make sure to insulate unplugged connectors electrically with a vinyl tape.
- Adjust the louver position slowly by hand so as to be within the applicable range mentioned below table.

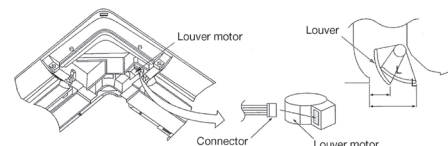

Range of louver setting		
Vertical airflow direction	Horizontal 23°	Downwards 50°
Dimension L (mm)	40	24

*It can be set between 24-40mm freely.

Caution

- Any automatic control or operation from the remote controller will be disabled on the louver whose position is fixed in the above way.
- Do not set a louver beyond the specified range. Failure to observe this instruction may result in dripping, dew condensation, the fouling of the ceiling and the malfunctioning of the unit.

Все каталоги и инструкции здесь: <http://splitoff.ru/tehn-doc.html>

*1. This function is not able to be set with wireless remote controls or simple remote control (RCH-H3).
 *2. For setting the swing range of other louvers, return to 1 and proceed same procedure respectively.

(b) Ceiling cassette-4way type (FDT)

This manual is for the installation of an indoor unit.

Все каталоги и инструкции здесь: <http://splitoff.ru/tehn-doc.html>

attached to an outdoor unit.
This unit must always be used with the panel.

SAFETY PRECAUTIONS

- Read the "SAFETY PRECAUTIONS" carefully first of all and then strictly follow it during the installation work in order to protect yourself.
- The precautionary items mentioned below are distinguished into two levels, **⚠WARNING** and **⚠CAUTION**.
⚠WARNING: Wrong installation would cause serious consequences such as injuries or death.
⚠CAUTION: Wrong installation might cause serious consequences depending on circumstances.
 Both mentions the important items to protect your health and safety so strictly follow them by any means.
 The meanings of "Marks" used here are as shown on the right:
 (⊘) Never do it under any circumstances. (⚠) Always do it according to the instruction.
- After completing the installation, do commissioning to confirm there are no abnormalities, and explain to the customers about "SAFETY PRECAUTIONS", correct operation method and maintenance method (air filter cleaning, operation method and temperature setting method) with user's manual of this unit. Ask your customers to keep this installation manual together with the user's manual. Also, ask them to hand over the user's manual to the new user when the owner is changed.

⚠ WARNING

- **Installation should be performed by the specialist.**
If you install the unit by yourself, it may lead to serious trouble such as water leakage, electric shock, fire, and injury due to overturn of the unit. (⚠)
- **Install the system correctly according to these installation manuals.**
Improper installation may cause explosion, injury, water leakage, electric shock and fire. (⚠)
- **Check the density referred by the formula (accordance with ISO5149).**
If the density exceeds the limit density, please consult the dealer and installate the ventilation system. (⚠)
- **Use the genuine accessories and the specified parts for installation.**
If parts unspecified by our company are used it could cause water leakage, electric shock, fire, and injury due to overturn of the unit. (⚠)
- **Ventilate the working area well in case the refrigerant leaks during installation.**
If the refrigerant contacts the fire, toxic gas is produced. (⚠)
- **Install the unit in a location that can hold heavy weight.**
Improper installation may cause the unit to fall leading to accidents. (⚠)
- **Install the unit properly in order to be able to withstand strong winds such as typhoons, and earthquakes.**
Improper installation may cause the unit to fall leading to accidents. (⚠)
- **Do not mix air in to the cooling cycle on installation or removal of the air conditioner.**
If air is mixed in, the pressure in the cooling cycle will rise abnormally and may cause explosion and injuries. (⊘)
- **Be sure to have the electrical wiring work done by qualified electrical installer, and use exclusive circuit.**
Power source with insufficient capacity and improper work can cause electric shock and fire. (⚠)
- **Use specified wire for electrical wiring, fasten the wiring to the terminal securely, and hold the cable securely in order not to apply unexpected stress on the terminal.**
Loose connections or hold could result in abnormal heat generation or fire. (⚠)
- **Arrange the electrical wires in the control box properly to prevent them from rising. Fit the lid of the services panel properly.**
Improper fitting may cause abnormal heat and fire. (⚠)
- **Check for refrigerant gas leakage after installation is completed.**
If the refrigerant gas leaks into the house and comes in contact with a fan heater, a stove, or an oven, toxic gas is produced. (⚠)
- **Use the specified pipe, flare nut, and tools for R410A.**
Using existing parts (R22) could cause the unit failure and serious accident due to explosion of the cooling cycle. (⚠)
- **Tighten the flare nut according to the specified method by with torque wrench.**
If the flare nut were tightened with excess torque, it could cause burst and refrigerant leakage after a long period. (⚠)
- **Do not put the drainage pipe directly into drainage channels where poisonous gases such as sulfide gas can occur.**
Poisonous gases will flow into the room through drainage pipe and seriously affect the user's health and safety. This can also cause the corrosion of the indoor unit and a resultant unit failure or refrigerant leak. (⊘)
- **Connect the pipes for refrigeration circuit securely in installation work before compressor is operated.**
If the compressor is operated when the service valve is open without connecting the pipe, it could cause explosion and injuries due to abnormal high pressure in the system. (⚠)
- **Stop the compressor before removing the pipe after shutting the service valve on pump down work.**
If the pipe is removed when the compressor is in operation with the service valve open, air would be mixed in the refrigeration circuit and it could cause explosion and injuries due to abnormal high pressure in the cooling cycle. (⚠)
- **Only use prescribed optional parts. The installation must be carried out by the qualified installer.**
If you install the system by yourself, it can cause serious trouble such as water leaks, electric shocks, fire. (⚠)
- **Do not repair by yourself. And consult with the dealer about repair.**
Improper repair may cause water leakage, electric shock or fire. (⊘)
- **Consult the dealer or a specialist about removal of the air conditioner.**
Improper installation may cause water leakage, electric shock or fire. (⚠)
- **Turn off the power source during servicing or inspection work.**
If the power is supplied during servicing or inspection work, it could cause electric shock and injury by the operating fan. (⚠)
- **Do not run the unit when the panel or protection guard are taken off.**
Touching the rotating equipment, hot surface, or high voltage section could cause an injury to be caught in the machine, to get burned, or electric shock. (⊘)
- **Shut off the power before electrical wiring work.**
It could cause electric shock, unit failure and improper running. (⚠)

- **Earth leakage breaker must be installed.**
If the earth leakage breaker is not installed, it can cause electric shocks. (⚠)
- **Use the circuit breaker of correct capacity. Circuit breaker should be the one that disconnect all poles under over current.**
Using the incorrect one could cause the system failure and fire. (⚠)
- **Do not use any materials other than a fuse of correct capacity where a fuse should be used.**
Connecting the circuit by wire or copper wire could cause unit failure and fire. (⊘)
- **Do not install the indoor unit near the location where there is possibility of flammable gas leakages.**
If the gas leaks and gathers around the unit, it could cause fire. (⊘)
- **Do not install and use the unit where corrosive gas (such as sulfurous acid gas etc.) or flammable gas (such as thinner, petroleum etc.) may be generated or accumulated, or volatile flammable substances are handled.**
It could cause the corrosion of heat exchanger, breakage of plastic parts etc. And inflammable gas could cause fire. (⊘)
- **Secure a space for installation, inspection and maintenance specified in the manual.**
Insufficient space can result in accident such as personal injury due to falling from the installation place. (⚠)
- **Do not use the indoor unit at the place where water splashes such as laundry.**
Indoor unit is not waterproof. It could cause electric shock and fire. (⊘)
- **Do not use the indoor unit for a special purpose such as food storage, cooling for precision instrument, preservation of animals, plants, and a work of art.**
It could cause the damage of the items. (⊘)
- **Do not install nor use the system near equipments which generate electromagnetic wave or high harmonics.**
Equipments like inverter equipment, private power generator, high-frequency medical equipment, or telecommunication equipment might influence the air conditioner and cause a malfunction and breakdown. Or the air conditioner might influence medical equipments or telecommunication equipments, and obstruct their medical activity or cause jamming. (⊘)
- **Do not install the remote controller at the direct sunlight.**
It could cause breakdown or deformation of the remote controller. (⊘)
- **Do not install the indoor unit at the place listed below.**
 - Places where flammable gas could leak.
 - Places where carbon fiber, metal powder or any powder is floated.
 - Place where the substances which affect the air conditioner are generated such as sulfide gas, chloride gas, acid, alkali or ammoniac atmospheres.
 - Places exposed to oil mist or steam directly.
 - On vehicles and ships
 - Places where machinery which generates high harmonics is used.
 - Places where cosmetics or special sprays are frequently used.
 - Highly salted area such as beach.
 - Heavy snow area.
 - Places where the system is affected by smoke from a chimney.
 - Altitude over 1000m
- **Do not install the indoor unit in the locations listed below (Be sure to install the indoor unit according to the installation manual for each model because each indoor unit has each limitation)**
 - Locations with any obstacles which can prevent inlet and outlet air of the unit
 - Locations where vibration can be amplified due to insufficient strength of structure.
 - Locations where the infrared receiver is exposed to the direct sunlight or the strong light beam. (in case of the infrared specification unit)
 - Locations where an equipment affected by high harmonics is placed. (TV set or radio receiver is placed within 5m)
 - Locations where drainage cannot run off safely.
 - It can affect performance or function and etc..
- **Do not put any valuables which will break down by getting wet under the air conditioner.**
Condensation could drop when the relative humidity is higher than 80% or drain pipe is clogged, and it damages user's belongings. (⊘)
- **Do not use the base frame for the outdoor unit which is corroded or damaged after a long period of use.**
It could cause the unit falling down and injury. (⊘)
- **Pay attention not to damage the drain pan by weld sputter when brazing work is done near the unit.**
If sputter entered into the unit during brazing work, it could cause damage (pinhole) of drain pan and leakage of water. To avoid damaging, keep the indoor unit packed or cover the indoor unit. (⚠)
- **Install the drain pipe to drain the water surely according to the installation manual.**
Improper connection of the drain pipe may cause dropping water into room and damaging user's belongings. (⚠)
- **Do not share the drain pipe for indoor unit and GHP (Gas Heat Pump system) outdoor unit.**
Toxic exhaust gas would flow into room and it might cause serious damage (some poisoning or deficiency of oxygen) to user's health and safety. (⊘)
- **Be sure to perform air tightness test by pressurizing with nitrogen gas after completed refrigerant piping work.**
If the density of refrigerant exceeds the limit in the event of refrigerant leakage in the small room, lack of oxygen can occur, which can cause serious accidents. (⚠)
- **For drain pipe installation, be sure to make descending slope of greater than 1/100, not to make traps, and not to make air-bleeding.**
Check if the drainage is correctly done during commissioning and ensure the space for inspection and maintenance. (⚠)
- **Ensure the insulation on the pipes for refrigeration circuit so as not to condense water.**
Incomplete insulation could cause condensation and it would wet ceiling, floor, and any other valuables. (⚠)
- **Do not install the outdoor unit where is likely to be a nest for insects and small animals.**
Insects and small animals could come into the electronic components and cause breakdown and fire. Instruct the user to keep the surroundings clean. (⊘)
- **Pay extra attention, carrying the unit by hand.**
Carry the unit with 2 people if it is heavier than 20kg. Do not use the plastic straps but the grabbing place, moving the unit by hand. Use protective gloves in order to avoid injury by the aluminum fin. (⚠)
- **Make sure to dispose of the packaging material.**
Leaving the materials may cause injury as metals like nail and woods are used in the package. (⚠)
- **Do not operate the system without the air filter.**
It may cause the breakdown of the system due to clogging of the heat exchanger. (⊘)
- **Do not touch any button with wet hands.**
It could cause electric shock. (⊘)
- **Do not touch the refrigerant piping with bare hands when in operation.**
The pipe during operation would become very hot or cold according to the operating condition, and it could cause a burn or frostbite. (⊘)
- **Do not clean up the air conditioner with water.**
It could cause electric shock. (⊘)
- **Do not turn off the power source immediately after stopping the operation.**
Be sure to wait for more than 5 minutes. Otherwise it could cause water leakage or breakdown. (⊘)
- **Do not control the operation with the circuit breaker.**
It could cause fire or water leakage. In addition, the fan may start operation unexpectedly and it may cause injury. (⊘)

① Before installation

- Install correctly according to the installation manual.
- Confirm the following points:
 - Unit type/Power supply specification
 - Pipes/Wires/Small parts
 - Accessory items

Accessory item								
8	1	1	1	4	1	1	1	
For unit hanging	For unit hanging and adjustment	For heat insulation of gas pipe	For heat insulation of liquid tube	For pipe cover fixing	For heat insulation of drain socket	For heat insulation of drain socket	For drain pipe connecting	For drain hose mounting

② Selection of installation location for the indoor unit

- Select the suitable areas to install the unit under approval of the user.
 - Areas where the indoor unit can deliver hot and cold wind sufficiently. Suggest to the user to use a circulator if the ceiling height is over 3m to avoid warm air being accumulated on the ceiling.
 - Areas where there is enough space to install and service.
 - Areas where it can be drained properly. Areas where drain pipe descending slope can be taken.
 - Areas where there is no obstruction of airflow on both air return grille and air supply port.
 - Areas where fire alarm will not be accidentally activated by the air conditioner.
 - Areas where the supply air does not short-circuit.
 - Areas where it is not influenced by draft air.
 - Areas not exposed to direct sunlight.
 - Areas where dew point is lower than around 28°C and relative humidity is lower than 80%.
 This indoor unit is tested under the condition of JIS (Japan Industrial Standard) high humidity condition and confirmed there is no problem. However, there is some risk of condensation drop if the air conditioner is operated under the severer condition than mentioned above.
 If there is a possibility to use it under such a condition, attach additional insulation of 10 to 20mm thick for entire surface of indoor unit, refrigeration pipe and drain pipe.
 - Areas where TV and radio stays away more than 1m. (It could cause jamming and noise.)
 - Areas where any items which will be damaged by getting wet are not placed such as food, table wares, server, or medical equipment under the unit.
 - Areas where there is no influence by the heat which cookware generates.
 - Areas where not exposed to oil mist, powder and/or steam directly such as above fryer.
 - Areas where lighting device such as fluorescent light or incandescent light doesn't affect the operation.
 (A beam from lighting device sometimes affects the infrared receiver for the wireless remote controller and the air conditioner might not work properly.)
- Check if the place where the air conditioner is installed can hold the weight of the unit. If it is not able to hold, reinforce the structure with boards and beams strong enough to hold it. If the strength is not enough, it could cause injury due to unit falling.
- If there are 2 units of wireless type, keep them away for more than 6m to avoid malfunction due to cross communication.
- When plural indoor units are installed nearby, keep them away for more than 4 to 5m.

Space for installation and service

- When it is not possible to keep enough space between indoor unit and wall or between indoor units, close the air supply port where it is not possible to keep space and confirm there is no short circuit of airflow.
- Install the indoor unit at a height of more than 2.5m above the floor.

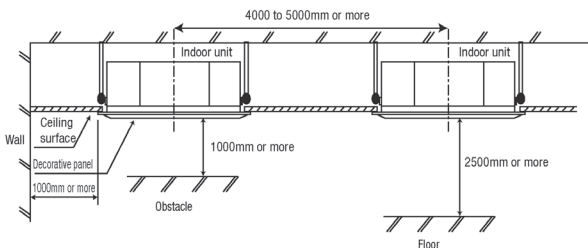

Set blow-out pattern

- Select the most proper number of blow-out air supply port direction from 4 way, 3 way or 2 way according to the shape of the room and installation position. (1 way is not available.)
- If it is necessary to change the number of air supply port, prepare the covering materials. (sold as accessory)
- Instruct the user not to use low fan speed when 2way or 3way air supply is used.
- Do not use 2way air supply port under high temperature and humidity environment. (Otherwise it could cause condensation and leakage of water.)
- It is possible to set the airflow direction port by port independently. Refer to the user's manual for details.

③ Preparation before installation

- If suspension bolt becomes longer, do reinforcement of earthquake resistant.
 - For grid ceiling
 When suspension bolt length is over 500mm, or the gap between the ceiling and roof is over 700mm, apply earthquake resistant brace to the bolt.

- Prepare four (4) sets of suspension bolt, nut and spring washer (M10 or M8) on site.

Ceiling opening, Suspension bolts pitch, Pipe position

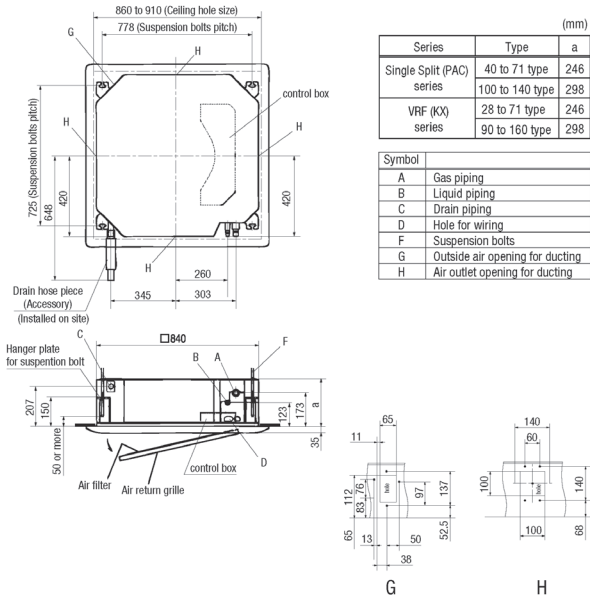

④ Installation of indoor unit

Work procedure

- Prepare a ceiling hole with the size of from 860mm × 860mm to 910mm × 910mm referring to the template attached in the package.
- Arrange the suspension bolt at the right position (725mm×778mm).
- Make sure to use four suspension bolts and fix them so as to be able to hold 500N load.
- Ensure that the lower end of the suspension bolt should be 50mm above the ceiling plane. Temporarily put the four lower nuts 150mm above the ceiling plane and the upper nuts on distant place from the lower nuts in order not to obstruct hanging the indoor unit or adjust the indoor unit position, and then hang the indoor unit.
- Adjust the indoor unit position after hanging it by inserting the level gauge attached on the package into the air supply port and checking if the gap between the ceiling plane and the indoor unit is appropriate. In order to adjust the indoor unit position, adjust the lower nuts while the upper nuts are put on distant place. Confirm there is no backlash between the hanger plate for suspension bolt and the lower nut and washer.

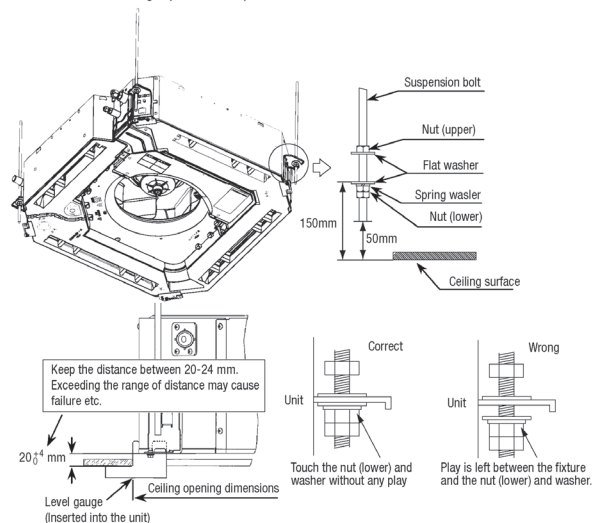

Все каталоги и инструкции здесь: <http://splitoff.ru/tehn-doc.html>

④ Installation of indoor unit (continued)

6. Make sure to install the indoor unit horizontally. Confirm the levelness of the indoor unit with a level gauge or transparent hose filled with water. Keep the height difference at both ends of the indoor unit within 3mm.



Все каталоги и инструкции здесь: <http://splitoff.ru/tehn-doc.html>

Caution

- Do not adjust the height by adjusting upper nuts. It will cause unexpected stress on the indoor unit and it will lead to deformation of the unit, failure of attaching a panel, and generating noise from the fan.
- Make sure to install the indoor unit horizontally and set the gap between the unit underside and the ceiling plane properly. Improper installation may cause air leakage, dew condensation, water leakage and noise.
- Even after decorative panel attached, still the unit height can be adjusted finely. Refer to the installation manual for decorative panel for details.
- Make sure there is no gap between decoration panel and ceiling surface, and between decoration panel and the indoor unit. The gap may cause air leakage, dew condensation and water leakage.
- In case decorative panel is not installed at the same time, or ceiling material is installed after the unit installed, put the cardboard template for installation attached on the package (packing material of cardboard box) on the bottom of the unit in order to avoid dust coming into the indoor unit.

⑤ Refrigerant pipe

Caution

- Use the new refrigerant pipe.
 - When re-using the existing pipe system for R22 or R407C, pay attention to the following items.
 - Change the flare nuts with the attached ones (JIS category 2), and reprocess the flare parts.
 - Do not use thin-walled pipes.
- Use phosphorus deoxidized copper alloy seamless pipe (C1220T specified in JIS H3300) for refrigeration pipe installation.
 - In addition, make sure there is no damage both inside and outside of the pipe, and no harmful substances such as sulfur, oxide, dust or a contaminant stuck on the pipes.
- Do not use any refrigerant other than R410A.
 - Using other refrigerant except R410A (R22 etc.) may degrade inside refrigeration oil. And air getting into refrigeration circuit may cause over-pressure and resultant it may result in bursting, etc.
- Store the copper pipes indoors and seal the both end of them until they are brazed in order to avoid any dust, dirt or water getting into pipe. Otherwise it will cause degradation of refrigeration oil and compressor breakdown, etc.
- Use special tools for R410 refrigerant.

Work procedure

1. Remove the flare nut and blind flanges on the pipe of the indoor unit.
 - ※ Make sure to loosen the flare nut with holding the nut on pipe side with a spanner and giving torque to the nut with another spanner in order to avoid unexpected stress to the copper pipe, and then remove them.
 - (Gas may come out at this time, but it is not abnormal.)
 - Pay attention whether the flare nut pops out. (as the indoor unit is sometimes pressured.)
2. Make a flare on liquid pipe and gas pipe, and connect the refrigeration pipes on the indoor unit.
 - ※ Bend the pipe with as big radius as possible and do not bend the pipe repeatedly. In addition, do not twist and crush the pipes.
 - ※ Do a flare connection as follows:
 - Make sure to loosen the flare nut with holding the nut on pipe side with a spanner and giving torque to the nut with another spanner in order to avoid unexpected stress to the copper pipe, and then remove them.
 - When fastening the flare nut, align the refrigeration pipe with the center of flare nut, screw the nut for 3-4 times by hand and then tighten it by spanner with the specified torque mentioned in the table below. Make sure to hold the pipe on the indoor unit securely by a spanner when tightening the nut in order to avoid unexpected stress on the copper pipe.
3. Cover the flare connection part of the indoor unit with attached insulation material after a gas leakage inspection, and tighten both ends with attached straps.
 - Make sure to insulate both gas pipes and liquid pipes completely.
 - ※ Incomplete insulation may cause dew condensation or water dropping.
4. Refrigerant is charged in the outdoor unit.
 - As for the additional refrigerant charge for the indoor unit and piping, refer to the installation manual attached to the outdoor unit.

Pipe diameter	Tightening torque N·m
φ 6.35	14 to 18
φ 9.52	34 to 42
φ 12.7	49 to 61
φ 15.88	68 to 82
φ 19.05	100 to 120

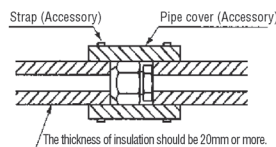

⑥ Drain pipe

Caution

- Install the drain pipe according to the installation manual in order to drain properly. Imperfection in draining may cause flood indoors and wetting the household goods, etc.
- Do not put the drain pipe directly into the ditch where toxic gas such as sulfur, the other harmful and it would cause serious gen). In addition, it may
- Connect the pipe securely to avoid water leakage from the joint.
- Insulate the pipe properly to avoid condensation drop.
- Check if the water can flow out properly from both the drain outlet on the indoor unit and the end of the drain pipe after installation.
- Make sure to make descending slope of greater than 1/100 and do not make up-down bend and/or trap in the midway. In addition, do not put air vent on the drain pipe. Check if water is drained out properly from the pipe during commissioning. Also, keep sufficient space for inspection and maintenance.

Work procedure

1. Make sure to insert the drain hose (the end made of soft PVC) to the end of the step part of drain socket.
 - Attach the hose clamp to the drain hose around 10mm from the end, and fasten the screw within 5mm left to the nut.
 - Do not apply adhesives on this end.

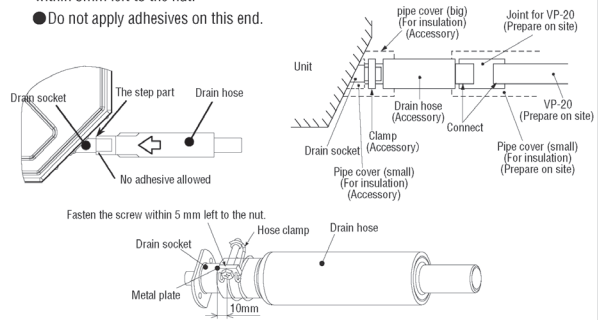

2. Prepare a joint for connecting VP-20 pipe, adhere and connect the joint to the drain hose (the end made of rigid PVC), and adhere and connect VP-20 pipe (prepare on site).
 - ※ As for drain pipe, apply VP-20 made of rigid PVC which is on the market.
 - Make sure that the adhesive will not get into the supplied drain hose.
 - It may cause the flexible part broken after the adhesive is dried up and gets rigid.
 - The flexible drain hose is intended to absorb a small difference at installation of the unit or drain pipes. Intentional bending, expanding may cause the flexible hose broken and water leakage.

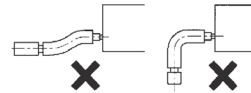

3. Make sure to make descending slope of greater than 1/100 and do not make up-down bend and/or trap in the midway.
 - Pay attention not to give stress on the pipe on the indoor unit side, and support and fix the pipe as close place to the unit as possible when connecting the drain pipe.
 - Do not set up air vent.

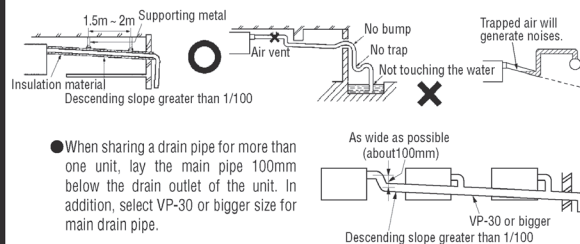

4. Insulate the drain pipe.
 - Be sure to insulate the drain socket and rigid PVC pipe installed indoors otherwise it may cause dew condensation and water leakage.
 - ※ After drainage test implementation, cover the drain socket part with pipe cover (small size), then use the pipe cover (big size) to cover the pipe cover (small size), clamps and part of the drain hose, and fix and wrap it with tapes to wrap and make joint part gapless.

Drain up

- The position for drain pipe outlet can be raised up to 700mm above the ceiling. Use elbows for installation to avoid obstacles inside ceiling. If the horizontal drain pipe is too long before vertical pipe, the backflow of water will increase when the unit is stopped, and it may cause overflow of water from the drain pan on the indoor unit. In order to avoid overflow, keep the horizontal pipe length and offset of the pipe within the limit shown in the figure below.

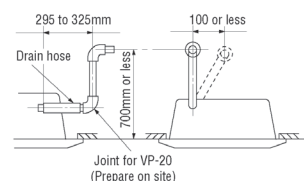

⑥ Drain pipe (continued)

Drain test

- After installation of drain pipe, make sure that drain system work in good condition and no

Все каталоги и инструкции здесь: <http://splitoff.ru/tehn-doc.html>

1. Pour water of about 1000cc into the drain pan in the indoor unit by pump so as not to get the electrical component wet.
2. Make sure that water is drained out properly and there is no water leakage from any joints of the drain pipe at the test.
Confirm that the water is properly drained out while the drain motor is operating. At the drain socket (transparent), it is possible to check if the water is drained out properly.
3. Unplug the drain plug on the indoor unit to remove remain ing water on the drain pan after the test, and re-plug it. And insulate the drain pipe properly finally.

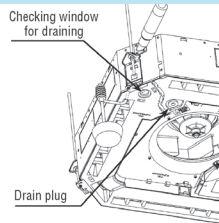

Drain pump operation

- In case electrical wiring work finished
Drain pump can be operated by remote controller (wired).
For the operation method, refer to [Operation for drain pump] in the installation manual for wiring work.
- In case electrical wiring work not finished
Drain pump will run continuously when the dip switch "SW7-1" on the indoor unit PCB is turned ON, the Connector CNB is disconnected, and then the power supply (230VAC on the terminal block ① and ②) is turned ON.
Make sure to turn OFF "SW7-1" and reconnect the Connector CNB after the test.

⑦ Wiring-out position and wiring connection

- Electrical installation work must be performed according to the installation manual by an electrical installation service provider qualified by a power provider of the country, and be executed according to the technical standards and other regulations applicable to electrical installation in the country.
Be sure to use an exclusive circuit.
- Use specified cord, fasten the wiring to the terminal securely, and hold the cord securely in order not to apply unexpected stress on the terminal.
- Do not put both power source line and signal line on the same route. It may cause miscommunication and malfunction.
- Be sure to do D type earth work.
- For the details of electrical wiring work, see attached instruction manual for electrical wiring work.

1. Remove a lid of the control box (3 screws) and the wiring cover (2 screws).
2. Hold each wiring inside the unit and fasten them to terminal block securely.
3. Fix the wiring with clamps.
4. Install the removed parts back to original place.

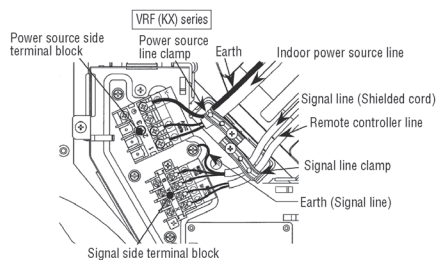
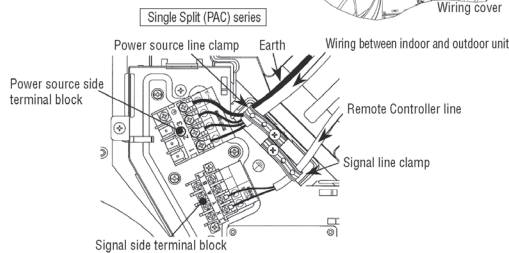
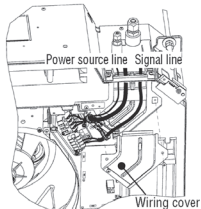

⑧ Panel installation

- Attach the panel on the indoor unit after electrical wiring work.
- Refer to attached manual for panel installation for details. (See next page)

- Check the following items after all installation work completed.

Check if:	Expected trouble	Check
The indoor and outdoor units are fixed securely?	Falling, vibration, noise	
Inspection for leakage is done?	Insufficient capacity	
Insulation work is properly done?	Water leakage	
Water is drained properly?	Water leakage	
Supply voltage is same as mentioned in the model name plate?	PCB burnt out, not working at all	
There is mis-wiring or mis-connection of piping?	PCB burnt out, not working at all	
Earth wiring is connected properly?	Electric shock	
Cable size comply with specified size?	PCB burnt out, not working at all	
Any obstacle blocks airflow on air inlet and outlet?	Insufficient capacity	

⑩ How to check the dirt of drain pan (Maintenance)

The method of checking the dirt of drain pan

- It is possible to check the dirt for inlet of drain pan without detaching the panel.
(Inspection is not possible when the high efficient filter and option spacer is installed.)

 1. Open the air return grille and remove the panel corner cover on drain pan side.
 2. Remove the cover of inspection window. (1 screw)
 3. Check the drain pan from the inspection window.
If the drain pan is very dirty, remove the drain pan and clean it.
 4. After checking of the dirty of drain pan, restore the cover of the inspection window securely. Improper restoration of the cover may cause dew condensation and water leakage.

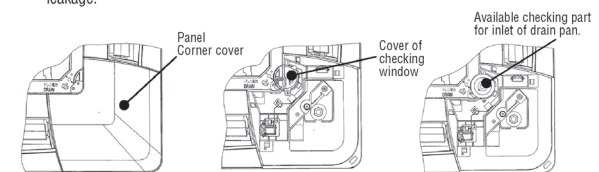

Attention for removing drain pan

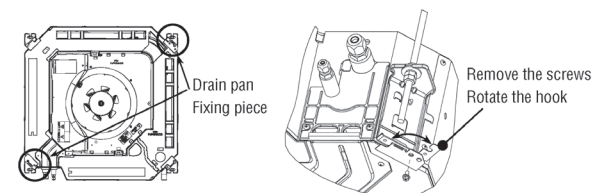

- The fixing components have been attached with the drain pan. Pay attention to these components during installation and removing. Take off the hanging hook after removing four screws. During the installation of drain pan, fix the drain pan firmly by using four screws after hanging it up with the fixing hook.



PANEL INSTALLATION MANUAL

PJF012D003A 

Все каталоги и инструкции здесь: <http://splitoff.ru/tehn-doc.html>

- Fasten the wiring to the terminal securely and hold the cable securely so as not to apply unexpected stress on the terminal. Loose connection or hold will cause abnormal heat generation or fire. 
- Make sure the power supply is turned off when electric wiring work. Otherwise, electric shock, malfunction and improper running may occur. 

① Before installation

- Follow installation manual carefully, and install the panel properly.
- Check the following items.
 - Accessories

Accessories

Bolt	4 pieces	For panel installation
Strap	4 pieces	For avoiding the corner panel from falling

Note: Accessories are laid in the position removing the corner panel.

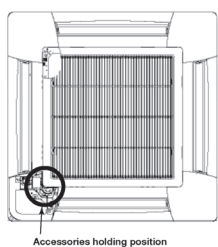

② Checking the indoor unit installation position

- Read this manual together with the air conditioner installation manual carefully.
- Check if the opening size for the indoor unit is correct with the level gauge supplied in the indoor unit.
- Check if the gap between the ceiling plane and the indoor unit is correct by inserting the level gauge into the air outlet part of the indoor unit. (See below drawing)
- Adjust the installation elevation if necessary.

Caution

If there is a height difference beyond the design limit between the installation level of the indoor unit and the ceiling plane, the panel may be subject to excessive stress during installation, it may cause distortion and damage.

- The installation level of the indoor unit can be adjusted finely from the opening provided on the corner, even after panel is attached. (Refer to ⑥ Attaching the panel for details.)

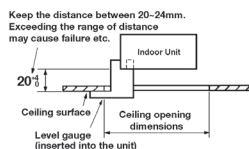

③ Removing the air return grille

1. Hold the stoppers on the air return grille (2 places) toward OPEN direction, open the air return grille.
2. Remove the hooks of the air return grille from the decorative panel while it is in the open position.

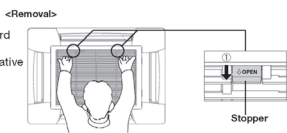

④ Removing a corner panel

- Pull the corner panel toward the direction indicated by the arrow and remove it. (Same way for all four corner panels)

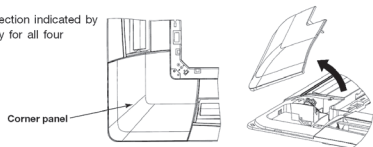

⑤ Orientation of the panel installation

- Take note that there is an orientation to install the panel.
- Attach the panel with the orientation shown on the right.
 - Align the "PIPE SIDE" mark (on the panel) with the refrigerant pipes on the indoor unit.
 - Align the "DRAIN" mark (on the panel) with the drain pipe on the indoor unit.

CAUTION

In case the orientation of the panel is not correct, it will lead to air leakage and also it is not possible to connect the lower motor wiring.

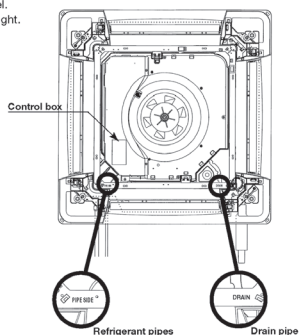

- Hang the panel on the hook on the indoor unit.

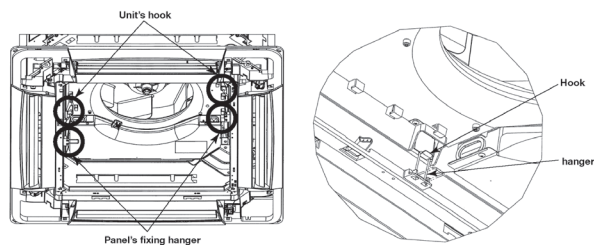

2. Fix the panel on the indoor unit

- Fasten the panel on the indoor unit with the four bolts supplied with the panel.

Caution

Improperly tightened hanging bolts can cause the problems listed below, so make sure that you have tightened them securely.

If there is a gap remaining between the ceiling and the decorative panel even after the hanging bolts are tightened, adjust the installation level of the indoor unit again.

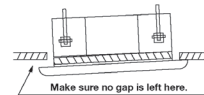
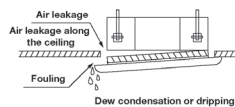

- It is possible to adjust the installation height of the indoor unit with the panel attached as long as there is no influence on the drain pipe inclination and/or the indoor unit levelness.

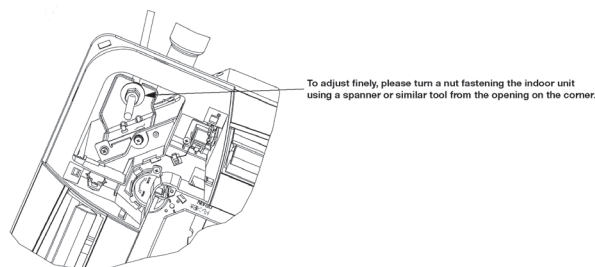

Caution

Make sure there is no stress given on the panel when adjusting the height of the indoor unit to avoid unexpected distortion. It may cause the distortion of panel or failing to close the air return grille.

⑦ Electrical wiring

1. After removing three screws of control box, detach the cover of control box (the hatched part).
2. Connect the connector for lower motor (white 20P).
 - Hold the wiring by using the clamps of the indoor unit.
 - Hold the connector inside the control box.
3. Connect the connector for panel switch.
 - Hold the wiring by using the clamps of the indoor unit.
 - Connect CNV (red) inside the control box.

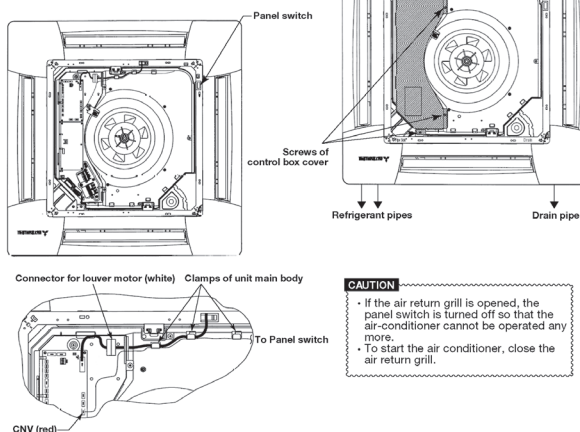

CAUTION

If the air return grill is opened, the panel switch is turned off so that the air-conditioner cannot be operated any more.

- To start the air conditioner, close the air return grill.

⑧ Attaching a corner panel

1. To avoid unexpected falling of the corner panel, put the strap onto the corner panel's pin with turning the strap up.
2. Then hang the strap of a corner panel onto the decorative panel's pin.
3. First insert the part "a" of a corner panel into the part "A" of the decorative panel, and then engage four hooks.

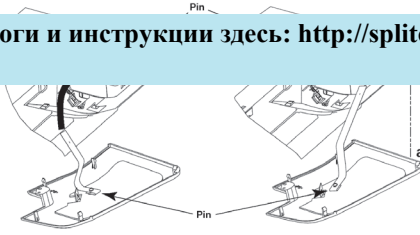

Все каталоги и инструкции здесь: <http://splitoff.ru/tehn-doc.html>

⑨ How to set the airflow direction *1

It is possible to change the movable range of the louver on the air outlet from the wired remote controller. Once the top and bottom position is set, the louver will swing within the range between the top and the bottom when swing operation is chosen. It is also possible to apply different setting to each louver.

1 Stop the air conditioner and press **SET button and **LOUVER** button simultaneously for three seconds or more.**

The following is displayed if the number of the indoor units connected to the remote controller is one. Go to step 4.

"DATA LOADING"

"No.1"

The following is displayed if the number of the indoor units connected to the remote controller are more than one

"SELECT 1/0"

"1/0000"

2 Press **▲ or **▼** button.(selection of indoor unit)**

Select the indoor unit of which the louver is set.

[EXAMPLE]

"1/0000"

"1/0003"

3 Press **SET button. (determination of indoor unit)**

Selected indoor unit is fixed.

[EXAMPLE]

"1/0001"

"DATA LOADING"

"No.1"

NOTICE

* For FDT type, in case the louver No. to be set is uncertain, set any louver temporarily. The louver will swing once when the setting is completed and it is possible to confirm the louver No. and the position. After that, choose the correct louver No. and set the top and bottom position.

4 Press **▲ or **▼** button. (selection of louver No.)**

Select the louver No. to be set according to the right figure.

[EXAMPLE]

"No.1"

"No.2"

"No.3"

"No.4"

5 Press **SET button. (Determination of louver No.)**

The louver No. to be set is confirmed and the display shows the upper limit of the movable range.

[EXAMPLE] If No.1 louver is selected,

"UPPER2"

"No.1"

6 Press **▲ or **▼** button. (selection of upper limit position)**

Select the upper limit of louver movable range.

"position 1" is the most horizontal, and "position 6" is the most downward.

"position --" is to return to the factory setting. If you need to change the setting to the default setting, use "position --".

"No.1 UPPER1"

"No.1 UPPER2"

"No.1 UPPER3"

"No.1 UPPER4"

"No.1 UPPER5"

"No.1 UPPER6"

"No.1 UPPER--"

7 Press **SET button (Fixing of the upper limit position)**

The upper limit position is fixed and the setting position is displayed for two seconds. Then proceed to lower limit position selection display.

[EXAMPLE]

"No.1 UPPER2"

"No.1 LOWER5"

8 Press **▲ or **▼** button (Selection of lower limit position)**

Select the lower limit position of louver.

"position 1" is the most horizontal, and "position 6" is the most downwards.

"position --" is to return to the factory setting. If you need to change the setting to the default setting, use "position --".

"No.1 LOWER1"

"No.1 LOWER2"

"No.1 LOWER3"

"No.1 LOWER4"

"No.1 LOWER5"

"No.1 LOWER6"

"No.1 LOWER--"

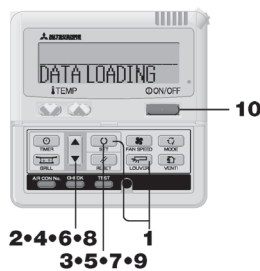

2•4•6•8 1
3•5•7•9

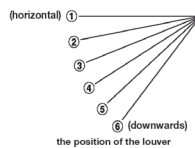
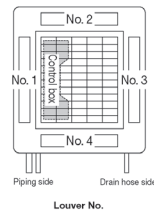

9 Press **SET button (Fixing of the lower limit position)**

Upper limit position and lower limit position are fixed, and the set positions are displayed for two seconds, then setting is completed. After the setting is completed, the louver which was set moves from the original position to the lower limit position, and goes

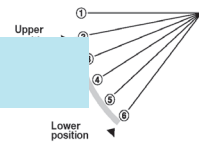

SET COMPLETE
No.1 ▲

10 Press **ON/OFF button.**

Louver adjusting mode ends and returns to the original display. *2

Caution

If the upper limit position number and the lower limit position number are set to the same position, the louver is fixed at that position auto swing does not function.

ATTENTION

If you press **RESET** button during settings, the display will return to previous display. If you press **ON/OFF** button during settings, the mode will be ended and return to original display, and the settings that have not been completed will become invalid.

When plural remote controllers are connected, louver setting operation cannot be set by slave remote controller.

If it is necessary to fix the louver position manually, follow the procedure mentioned below.

1. Shut off the main power switch.
2. Unplug the connector of the louver motor which you want to fix the position. Make sure to insulate unplugged connectors electrically with a vinyl tape.
3. Adjust the louver position slowly by hand so as to be within the applicable range mentioned below table.

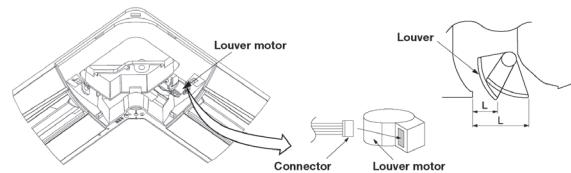

<Range of louver setting>

Vertical airflow direction	Horizontal 0°	Downwards 45°
Dimension L (mm)	43	26

*It can be set between 26-43mm freely.

Caution

- Any automatic control or operation from the remote controller will be disabled on the louver whose position is fixed in the above way.
- Do not set a louver beyond the specified range. Failure to observe this instruction may result in dripping, dew condensation, the fouling of the ceiling and the malfunctioning of the unit.

⑩ Attaching the air return grille

To attach the air return grille, follow the procedure described in **⑨ Removing the air return grille** in the reverse order.

1. Hang the hooks of the air return grille in the hole of the panel. (The hooks of the grille can be hung in three side of the panel as following.)
2. After the grille is hanged, close the grille while the stoppers on the grille (2 places) are kept pressed to "OPEN" direction. When the grille comes to the original position, release the stoppers to hold the grille. Make sure to hear the sound of "CLICK" in both stoppers.

<Installation>

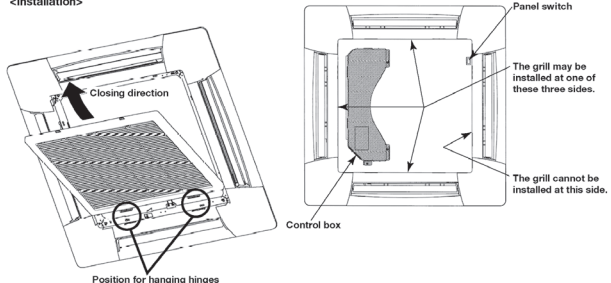

Caution

- Attaching the air return grille from the hinge side.
- Be careful in air return grille attaching, unstable attaching may cause grille falling.
- Repair or replace the distorted, broken stopper at once, or the grille falling may occur.

*1. This function is not able to be set with wireless remote controls or simple remote control (RCH-H3).

*2. For setting the swing range of other louvers, return to 1 and proceed same procedure respectively.

(c) Ceiling suspended type (FDEN)

This manual is for the installation of an indoor unit.

Все каталоги и инструкции здесь: <http://splitoff.ru/tehn-doc.html>

work installation for outdoor unit, refer to the installation manual attached to an outdoor unit.

SAFETY PRECAUTIONS

- Read the "SAFETY PRECAUTIONS" carefully first of all and then strictly follow it during the installation work in order to protect yourself.
- The precautionary items mentioned below are distinguished into two levels, **⚠ WARNING** and **⚠ CAUTION**.
⚠ WARNING: Wrong installation would cause serious consequences such as injuries or death.
⚠ CAUTION: Wrong installation might cause serious consequences depending on circumstances.
 Both mentions the important items to protect your health and safety so strictly follow them by any means.
- The meanings of "Marks" used here are as shown as follows:
 ⊕ Never do it under any circumstances. ⊕ Always do it according to the instruction.
- After completing the installation, do commissioning to confirm there are no abnormalities, and explain to the customers about "SAFETY PRECAUTIONS", correct operation method and maintenance method (air filter cleaning, operation method and temperature setting method) with user's manual of this unit. Ask your customers to keep this installation manual together with the user's manual. Also, ask them to hand over the user's manual to the new user when the owner is changed.

⚠ WARNING

- **Installation should be performed by the specialist.** ⊕
 If you install the unit by yourself, it may lead to serious trouble such as water leakage, electric shock, fire, and injury due to overturn of the unit.
- **Install the system correctly according to these installation manuals.** ⊕
 Improper installation may cause explosion, injury, water leakage, electric shock, and fire.
- **When installing in small rooms, take prevention measures not to exceed the density limit of refrigerant in the event of leakage, referred by the formula (accordance with ISO5149).** ⊕
 If the density of refrigerant exceeds the limit, please consult the dealer and install the ventilation system, otherwise lack of oxygen can occur, which can cause serious accidents.
- **Use the genuine accessories and the specified parts for installation.** ⊕
 If parts unspecified by our company are used it could cause water leakage, electric shock, fire, and injury due to overturn of the unit.
- **Ventilate the working area well in case the refrigerant leaks during installation.** ⊕
 If the refrigerant contacts the fire, toxic gas is produced.
- **Install the unit in a location that can hold heavy weight.** ⊕
 Improper installation may cause the unit to fall leading to accidents.
- **Install the unit properly in order to be able to withstand strong winds such as typhoons, and earthquakes.** ⊕
 Improper installation may cause the unit to fall leading to accidents.
- **Do not mix air in to the cooling cycle on installation or removal of the air conditioner.** ⊕
 If air is mixed in, the pressure in the cooling cycle will rise abnormally and may cause explosion and injuries.
- **Be sure to have the electrical wiring work done by qualified electrical installer, and use exclusive circuit.** ⊕
 Power source with insufficient capacity and improper work can cause electric shock and fire.
- **Use specified wire for electrical wiring, fasten the wiring to the terminal securely, and hold the cable securely in order not to apply unexpected stress on the terminal.** ⊕
 Loose connections or hold could result in abnormal heat generation or fire.
- **Arrange the electrical wires in the control box properly to prevent them from rising. Fit the lid of the services panel properly.** ⊕
 Improper fitting may cause abnormal heat and fire.
- **Check for refrigerant gas leakage after installation is completed.** ⊕
 If the refrigerant gas leaks into the house and comes in contact with a fan heater, a stove, or an oven, toxic gas is produced.
- **Use the specified pipe, flare nut, and tools for R410A.** ⊕
 Using existing parts (R22) could cause the unit failure and serious accident due to explosion of the cooling cycle.
- **Tighten the flare nut according to the specified method by with torque wrench.** ⊕
 If the flare nut were tightened with excess torque, it could cause burst and refrigerant leakage after a long period.
- **Do not put the drainage pipe directly into drainage channels where poisonous gases such as sulfide gas can occur.** ⊕
 Poisonous gases will flow into the room through drainage pipe and seriously affect the user's health and safety. This can also cause the corrosion of the indoor unit and a resultant unit failure or refrigerant leak.
- **Connect the pipes for refrigeration circuit securely in installation work before compressor is operated.** ⊕
 If the compressor is operated when the service valve is open without connecting the pipe, it could cause explosion and injuries due to abnormal high pressure in the system.
- **Stop the compressor before removing the pipe after shutting the service valve on pump down work.** ⊕
 If the pipe is removed when the compressor is in operation with the service valve open, air would be mixed in the refrigeration circuit and it could cause explosion and injuries due to abnormal high pressure in the cooling cycle.
- **Only use prescribed optional parts. The installation must be carried out by the qualified installer.** ⊕
 If you install the system by yourself, it can cause serious trouble such as water leaks, electric shocks, fire.
- **Do not repair by yourself. And consult with the dealer about repair.** ⊕
 Improper repair may cause water leakage, electric shock or fire.
- **Consult the dealer or a specialist about removal of the air conditioner.** ⊕
 Improper installation may cause water leakage, electric shock or fire.
- **Turn off the power source during servicing or inspection work.** ⊕
 If the power is supplied during servicing or inspection work, it could cause electric shock and injury by the operating fan.
- **Do not run the unit when the panel or protection guard are taken off.** ⊕
 Touching the rotating equipment, hot surface, or high voltage section could cause an injury to be caught in the machine, to get burned, or electric shock.
- **Shut off the power before electrical wiring work.** ⊕
 It could cause electric shock, unit failure and improper running.

- **Earth leakage breaker must be installed.** ⊕
 If the earth leakage breaker is not installed, it can cause electric shocks.
- **Use the circuit breaker of correct capacity. Circuit breaker should be the one that disconnect all poles under over current.** ⊕
 Using the incorrect one could cause the system failure and fire.
- **Do not use any materials other than a fuse of correct capacity where a fuse should be used.** ⊕
 Connecting the circuit by wire or copper wire could cause unit failure and fire.
- **Do not install the indoor unit near the location where there is possibility of flammable gas leakages.** ⊕
 If the gas leaks and gathers around the unit, it could cause fire.
- **Do not install and use the unit where corrosive gas (such as sulfurous acid gas etc.) or flammable gas (such as thinner, petroleum etc.) may be generated or accumulated, or volatile flammable substances are handled.** ⊕
 It could cause the corrosion of heat exchanger, breakage of plastic parts etc. And inflammable gas could cause fire.
- **Secure a space for installation, inspection and maintenance specified in the manual.** ⊕
 Insufficient space can result in accident such as personal injury due to falling from the installation place.
- **Do not use the indoor unit at the place where water splashes such as laundry.** ⊕
 Indoor unit is not waterproof. It could cause electric shock and fire.
- **Do not use the indoor unit for a special purpose such as food storage, cooling for precision instrument, preservation of animals, plants, and a work of art.** ⊕
 It could cause the damage of the items.
- **Do not install nor use the system near equipments which generate electromagnetic wave or high harmonics.** ⊕
 Equipments like inverter equipment, private power generator, high-frequency medical equipment, or telecommunication equipment might influence the air conditioner and cause a malfunction and breakdown. Or the air conditioner might influence medical equipments or telecommunication equipments, and obstruct their medical activity or cause jamming.
- **Do not install the remote controller at the direct sunlight.** ⊕
 It could cause breakdown or deformation of the remote controller.
- **Do not install the indoor unit at the place listed below.** ⊕
 - Places where flammable gas could leak.
 - Places where carbon fiber, metal powder or any powder is floated.
 - Place where the substances which affect the air conditioner are generated such as sulfide gas, chloride gas, acid, alkali or ammoniac atmospheres.
 - Places exposed to oil mist or steam directly.
 - On vehicles and ships
 - Places where machinery which generates high harmonics is used.
 - Places where cosmetics or special sprays are frequently used.
 - Highly salted area such as beach.
 - Heavy snow area
 - Places where the system is affected by smoke from a chimney.
 - Altitude over 1000m
- **Do not install the indoor unit in the locations listed below (Be sure to install the indoor unit according to the installation manual for each model because each indoor unit has each limitation)** ⊕
 - Locations with any obstacles which can prevent inlet and outlet air of the unit
 - Locations where vibration can be amplified due to insufficient strength of structure.
 - Locations where the infrared receiver is exposed to the direct sunlight or the strong light beam. (in case of the infrared specification unit)
 - Locations where an equipment affected by high harmonics is placed. (TV set or radio receiver is placed within 5m)
 - Locations where drainage cannot run off safely.
 It can affect performance or function and etc..
- **Do not put any valuables which will break down by getting wet under the air conditioner.** ⊕
 Condensation could drop when the relative humidity is higher than 80% or drain pipe is clogged, and it damages user's belongings.
- **Do not use the base frame for the outdoor unit which is corroded or damaged after a long period of use.** ⊕
 It could cause the unit falling down and injury.
- **Pay attention not to damage the drain pan by weld sputter when brazing work is done near the unit.** ⊕
 If sputter entered into the unit during brazing work, it could cause damage (pinhole) of drain pan and leakage of water. To avoid damaging, keep the indoor unit packed or cover the indoor unit.
- **Install the drain pipe to drain the water surely according to the installation manual.** ⊕
 Improper connection of the drain pipe may cause dropping water into room and damaging user's belongings.
- **Do not share the drain pipe for indoor unit and GHP (Gas Heat Pump system) outdoor unit.** ⊕
 Toxic exhaust gas would flow into room and it might cause serious damage (some poisoning or deficiency of oxygen) to user's health and safety.
- **Be sure to perform air tightness test by pressurizing with nitrogen gas after completed refrigerant piping work.** ⊕
 If the density of refrigerant exceeds the limit in the event of refrigerant leakage in the small room, lack of oxygen can occur, which can cause serious accidents.
- **For drain pipe installation, be sure to make descending slope of greater than 1/100, not to make traps, and not to make air-bleeding.** ⊕
 Check if the drainage is correctly done during commissioning and ensure the space for inspection and maintenance.
- **Ensure the insulation on the pipes for refrigeration circuit so as not to condense water.** ⊕
 Incomplete insulation could cause condensation and it would wet ceiling, floor, and any other valuables.
- **Do not install the outdoor unit where is likely to be a nest for insects and small animals.** ⊕
 Insects and small animals could come into the electronic components and cause breakdown and fire. Instruct the user to keep the surroundings clean.
- **Pay extra attention, carrying the unit by hand.** ⊕
 Carry the unit with 2 people if it is heavier than 20kg. Do not use the plastic straps but the grabbing place, moving the unit by hand. Use protective gloves in order to avoid injury by the aluminum fin.
- **Make sure to dispose of the packaging material.** ⊕
 Leaving the materials may cause injury as metals like nail and woods are used in the package.
- **Do not operate the system without the air filter.** ⊕
 It may cause the breakdown of the system due to clogging of the heat exchanger.
- **Do not touch any button with wet hands.** ⊕
 It could cause electric shock.
- **Do not touch the refrigerant piping with bare hands when in operation.** ⊕
 The pipe during operation would become very hot or cold according to the operating condition, and it could cause a burn or frostbite.
- **Do not clean up the air conditioner with water.** ⊕
 It could cause electric shock.
- **Do not turn off the power source immediately after stopping the operation.** ⊕
 Be sure to wait for more than 5 minutes. Otherwise it could cause water leakage or breakdown.
- **Do not control the operation with the circuit breaker.** ⊕
 It could cause fire or water leakage. In addition, the fan may start operation unexpectedly and it may cause injury.

① Before installation

- Install correctly according to the installation manual.
- Confirm the following points:
 - Unit type/Power supply specification
 - Pipes/Wires/Small parts
 - Accessory items

Ret washer (M10)	Paper pattern	Pipe cover (large)	Pipe cover (small)	Strap	Drain hose (with clamp)	Hose clamp	Fixing bracket	Screw	Heat insulation	Screw
8	1	1	1	4	1	1	1	2	1	4
For unit hanging	For unit hanging and adjustment	For heat insulation of gas pipe	For heat insulation of liquid pipe	For fixing of pipe cover	For drain pipe connection	For drain hose mounting	For fixing of drain hose	For installing of fixing bracket	For drain hose	For fixing air return grille

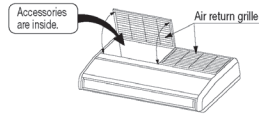

② Selection of installation location for the indoor unit

- Select the suitable areas to install the unit under approval of the user.
 - Areas where the indoor unit can deliver hot and cold wind sufficiently. Suggest to the user to use a circulator if the ceiling height is over 3m to avoid warm air being accumulated on the ceiling.
 - Areas where there is enough space to install and service.
 - Areas where it can be drained properly. Areas where drain pipe descending slope can be taken.
 - Areas where there is no obstruction of airflow on both air return grille and air supply port.
 - Areas where fire alarm will not be accidentally activated by the air conditioner.
 - Areas where the supply air does not short-circuit.
 - Areas where it is not influenced by draft air.
 - Areas not exposed to direct sunlight.
 - Areas where dew point is lower than around 23°C and relative humidity is lower than 80%. This indoor unit is tested under the condition of JIS (Japan Industrial Standard) high humidity condition and confirmed there is no problem. However, there is some risk of condensation drop if the air conditioner is operated under the severer condition than mentioned above.
 - Areas where TV and radio stays away more than 1m. (It could cause jamming and noise.)
 - Areas where any items which will be damaged by getting wet are not placed such as food, table wares, server, or medical equipment under the unit.
 - Areas where there is no influence by the heat which cookware generates.
 - Areas where not exposed to oil mist, powder and/or steam directly such as above fryer.
 - Areas where lighting device such as fluorescent light or incandescent light doesn't affect the operation. (A beam from lighting device sometimes affects the infrared receiver for the wireless remote controller and the air conditioner might not work properly.)
- Check if the place where the air conditioner is installed can hold the weight of the unit. If it is not able to hold, reinforce the structure with boards and beams strong enough to hold it. If the strength is not enough, it could cause injury due to unit falling.
- If there are 2 units of wireless type, keep them away for more than 6m to avoid malfunction due to cross communication.
- When plural indoor units are installed nearby, keep them away for more than 4 to 5m.

Space for installation and service

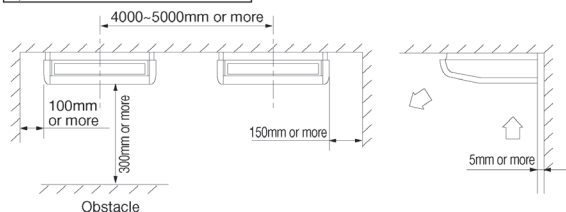

③ Preparation before installation

- If suspension bolt becomes longer, do reinforcement of earthquake resistant.
 - For grid ceiling
 - When suspension bolt length is over 500mm, or the gap between the ceiling and roof is over 700mm, apply earthquake resistant brace to the bolt.
 - In case the unit is hanged directly from the slab and is installed on the ceiling plane which has enough strength.
 - When suspension bolt length is over 1000mm, apply the earthquake resistant brace to the bolt.
- Prepare four (4) sets of suspension bolt, nut and spring washer (M10) on site.

③ Preparation before installation (continued)

Pitch of suspension bolts and pipe position



Series	type	(mm)	
		A	B
Single Split (PAC) series	40 to 50type	1070	1022
	60 to 71type	1320	1272
	100 to 140type	1620	1572
	6type	1070	1022
	7type	1320	1272
	40type	1620	1572

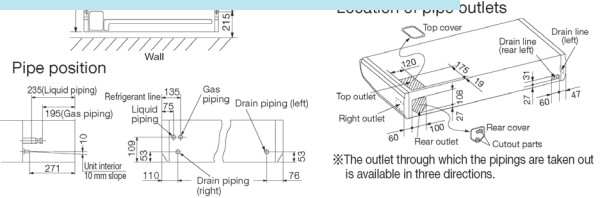

Haulage

- Move the box as close to the installation area as possible packed.
- If it must be unpacked, wrap the unit with a nylon sling, and be careful not to damage the unit.
- If you need to lay the unit on a floor after unpacking, always put it with the intake grille facing upward.



Preparation before installation

1. Remove the air return grille.

Slide stoppers (4 places) of the catches, then pull out the pins (4 or 6 places).

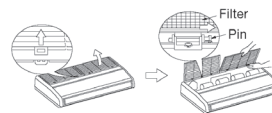

2. Remove the side panel.

Remove the screw and detach the side panel by sliding it toward the direction indicated by the arrow mark.

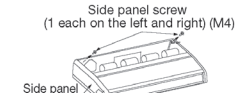

3. Remove the hanging plate.

Remove the screw, and then loosen the fixing bolts.

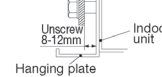

④ Remote controller

Installation of remote controller

Up to two receiver or wired remote controller can be installed in one indoor unit group.

- When both wired and wireless remote controller are used
 - It is necessary to set wired or wireless remote controller as slave. (For the method of changing the setting, refer to the installation manual attached to remote controller or wireless kit.)
- When wired remote controller are used only (wireless type)
 - It is necessary to remove the line that is connected to the receiver. Remove signal line connected to the receiver from primary side of terminal block (X, Y).

ATTENTION

- ① Insulate with tape the removed line.
- ② The LED of that removed connector will not be able to make any indication.

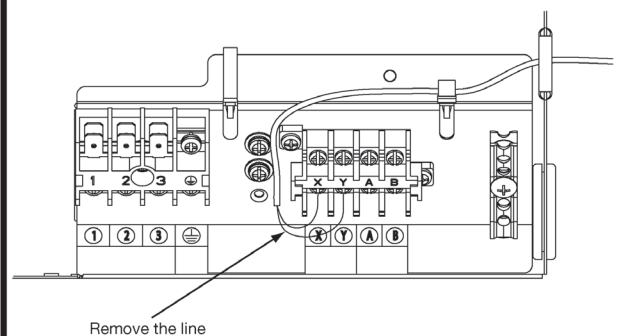

⑤ Installation of indoor unit

Work procedure

- Select the suspension bolt locations and the pipe hole location.
(1) Use enclosed paper pattern as a reference, and drill the holes for the suspension bolts and pipe.

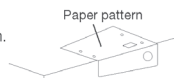

- Install the suspension bolts in place.
- Fix with 4 suspension bolts, which can endure load of 500N.
- Check the measurements given at the right figure for the length of the suspension bolts.



- Fasten the hanging plate onto the suspension bolts.

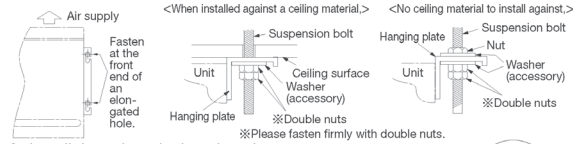

- Install the unit to the hanging plate.

- Slide the unit in from front side to get it hanged on the hanging plate with the bolts.
- Fasten the four fixing bolts (M8: 2 each on the left and right sides) firmly.
- Fasten the two screws (M4: 1 each on the left and right sides).

⚠WARNING : Hang a side panel on from the panel side to the rear side and then fasten it securely onto the indoor unit with screws.

※To ensure smooth drain flow, install the unit with a descending slope toward the drain outlet.

⚠CAUTION : Do not give the reversed slope, which may cause water leaks.

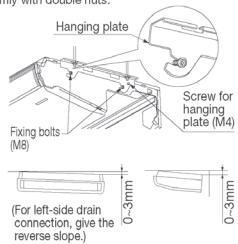

⑥ Refrigerant pipe

Caution

- Use the new refrigerant pipe.
 - When re-using the existing pipe system for R22 or R407C, pay attention to the following items.
 - Change the flare nuts with the attached ones (JIS category 2), and reprocess the flare parts.
 - Do not use thin-walled pipes.
- Use phosphorus deoxidized copper alloy seamless pipe (C1220T specified in JIS H3300) for refrigeration pipe installation. In addition, make sure there is no damage both inside and outside of the pipe, and no harmful substances such as sulfur, oxide, dust or a contaminant stuck on the pipes.
- Do not use any refrigerant other than R410A.
 - Using other refrigerant except R410A (R22 etc.) may degrade inside refrigeration oil. And air getting into refrigeration circuit may cause over-pressure and resultant it may result in bursting, etc.
- Store the copper pipes indoors and seal the both end of them until they are brazed in order to avoid any dust, dirt or water getting into pipe. Otherwise it will cause degradation of refrigeration oil and compressor breakdown, etc.
- Use special tools for R410 refrigerant.

Work procedure

- Remove the flare nut and blind flanges on the pipe of the indoor unit.
 - ※Make sure to loosen the flare nut with holding the nut on pipe side with a spanner and giving torque to the nut with another spanner in order to avoid unexpected stress to the copper pipe, and then remove them. (Gas may come out at this time, but it is not abnormal.)
 - Pay attention whether the flare nut pops out. (as the indoor unit is sometimes pressured.)
- Make a flare on liquid pipe and gas pipe, and connect the refrigeration pipes on the indoor unit.
 - ※Bend the pipe with as big radius as possible and do not bend the pipe repeatedly.
 - Do a flare connection as follows:
 - Make sure to loosen the flare nut with holding the nut on pipe side with a spanner and giving torque to the nut with another spanner in order to avoid unexpected stress to the copper pipe, and then remove them.
 - When fastening the flare nut, align the refrigeration pipe with the center of flare nut, screw the nut for 3-4 times by hand and then tighten it by spanner with the specified torque mentioned in the table below. Make sure to hold the pipe on the indoor unit securely by a spanner when tightening the nut in order to avoid unexpected stress on the copper pipe.
- Cover the flare connection part of the indoor unit with attached insulation material after a gas leakage inspection, and tighten both ends with attached straps.
 - Make sure to insulate both gas pipes and liquid pipes completely.
 - ※Incomplete insulation may cause dew condensation or water drooping.
- Refrigerant is charged in the outdoor unit.
 - As for the additional refrigerant charge for the indoor unit and piping, refer to the installation manual attached to the outdoor unit.

Pipe diameter	Tightening torque N·m
φ 6.35	14 to 18
φ 9.52	34 to 42
φ 12.7	49 to 61
φ 15.88	68 to 82
φ 19.05	100 to 120

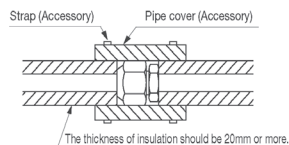

⑥ Refrigerant pipe (continued)

The pipe can be connected from three different directions. (back, right, top)

- When the pipe is routed through the back.
 - If the bracket is removed, piping work will become easy.

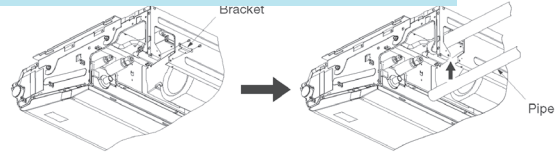

- When the pipe is routed through the back.
 - Cut the removed top cover, and install to the rear panel instead of rear cover.

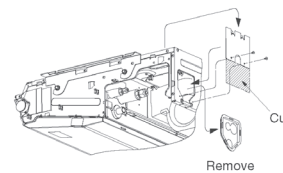

⑦ Drain pipe

The drain pipes may face out towards the back to the left, or to the right side.

Caution

- Install the drain pipe according to the installation manual in order to drain properly. Imperfection in draining may cause flood indoors and wetting the household goods, etc.
- Do not put the drain pipe directly into the ditch where toxic gas such as sulfur, the other harmful and inflammable gas is generated. Toxic gas would flow into the room and it would cause serious damage to user's health and safety (some poisoning or deficiency of oxygen). In addition, it may cause corrosion of heat exchanger and bad smell.
- Connect the pipe securely to avoid water leakage from the joint.
- Insulate the pipe properly to avoid condensation drop.
- Check if the water can flow out properly from both the drain outlet on the indoor unit and the end of the drain pipe after installation.
- Make sure to make descending slope of greater than 1/100 and do not make up-down bend and/or trap in the midway. In addition, do not put air vent on the drain pipe. Check if water is drained out properly from the pipe during commissioning. Also, keep sufficient space for inspection and maintenance.

Work procedure

- Insert drain hose completely to the base, and tighten the drain hose clamp securely. (adhesive must not be used.)
 - ※ When plumbing on the left side, move the rubber plug and the cylindrical insulating materials by the pipe connecting hole on the left side of the unit to the right side.
- Beware of a possible outflow of water that may occur upon removal of a drain plug.
 - Fix the drain hose at the lowest point with a hose clamp supplied as an accessory.
 - Give a drain hose a gradient of 10mm as illustrated in the right drawing by laying it without leaving a slack.
 - Take head of electrical cables so that they may not run beneath the drain hose.
- A drain hose must be clamped down with a hose clamp. There is a possibility that drain water overflows.
 - Connect VP-20(prepare on site) to drain hose. (adhesive must not be used.)
 - Use commercially available rigid PVC general pipe VP-20 for drain pipe.
- Do not to make the up-down bending and trap in the mid-way while assuming that the drain pipes is downhill. (more than 1/100)
 - Never set up air vent.
- Insulate the drain pipe.
 - Insulate the drain hose clamp with the heat insulation supplied as accessories.
 - When the unit is installed in a humid place, consider precautions against dew condensation such as heat insulation for the drain pipe.

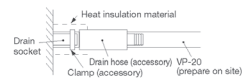

Drain test

- After installation of drain pipe, make sure that drain system work in good condition and no water leakage from joint and drain pan.
- Do drain test even if installation of heating season.

Все каталоги и инструкции здесь: <http://splitoff.ru/tehn-doc.html>

8 Wiring-out position and wiring connection

- Electrical installation work must be performed according to the installation manual by an electrical installation service provider qualified by a power provider of the country, and be executed according to the technical standards and other regulations applicable to electrical installation in the country.

Все каталоги и инструкции здесь: <http://splitoff.ru/tehn-doc.html>

- cord securely in order not to apply unexpected stress on the terminal.
- Do not put both power source line and signal line on the same route. It may cause miscommunication and malfunction.
- Be sure to do D type earth work.
- For the details of electrical wiring work, see attached instruction manual for electrical wiring work.

- Remove a lid of the electrical box (2 screws).
- Hold each wiring inside the unit and connect to a terminal block surely.
- Fix the wiring by clamps.
- Install the removed parts back to original place.

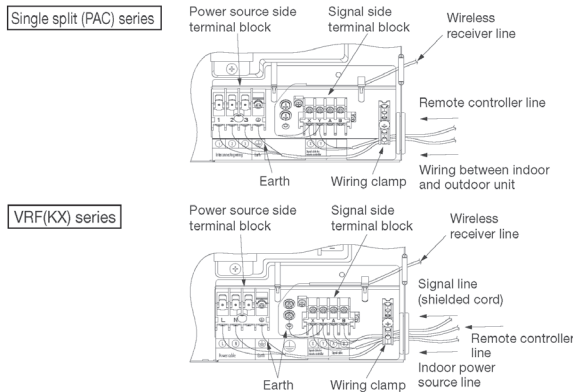

9 Attaching the air return grille

- The air return grille must be attached when electrical cabling work is completed.

- Fix the chains tied to the air return grille onto the indoor unit with screws supplied as accessories (4 pieces).
- Close the air return grille. This completes the unit installation work.

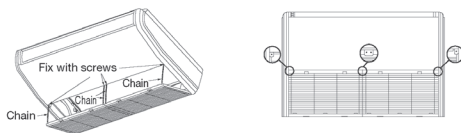

10 Check list after installation

- Check the following items after all installation work completed.

Check if	Expected trouble	Check
The indoor and outdoor units are fixed securely?	Falling, vibration, noise	
Inspection for leakage is done?	Insufficient capacity	
Insulation work is properly done?	Water leakage	
Water is drained properly?	Water leakage	
Supply voltage is same as mentioned in the model name plate?	PCB burnt out, not working at all	
There is mis-wiring or mis-connection of piping?	PCB burnt out, not working at all	
Earth wiring is connected properly?	Electric shock	
Cable size comply with specified size?	PCB burnt out, not working at all	
Any obstacle blocks airflow on air inlet and outlet?	Insufficient capacity	

11 How to set the airflow direction *1

It is possible to change the movable range of the louver on the air outlet from the wired remote controller. Once the top and bottom position is set, the louver will swing within the range between the top and the bottom when swing operation is chosen. It is also possible to set different settings to each louver.

- The following is displayed if the number of the indoor units connected to the remote controller is one. Go to step 4.
- The following is displayed if the number of the indoor units connected to the remote controller are more than one.

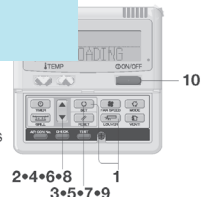

- Press **▲** or **▼** button. (selection of indoor unit) ● Select the indoor unit of which the louver is set.
- Press **○** SET button. (determination of indoor unit) ● Selected indoor unit is fixed.
- Press **▲** or **▼** button. (selection of louver No.) ● Select the louver No. to be set according to the right figure.

- Press **○** SET button. (Determination of louver No.) ● The louver No. to be set is confirmed and the display shows the upper limit of the movable range.
- Press **▲** or **▼** button. (selection of upper limit position) ● Select the upper limit of louver movable range. "position 1" is the most horizontal, and "position 6" is the most downwards. "position --" is to return to the factory setting. If you need to change the setting to the default setting, use "position --".

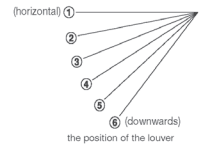

- Press **○** SET button. (Fixing of the upper limit position) ● The upper limit position is fixed and the setting position is displayed for two seconds. Then proceed to lower limit position selection display.
- Press **▲** or **▼** button. (Selection of lower limit position) ● Select the lower limit position of louver. "position 1" is the most horizontal, and "position 6" is the most downwards. "position --" is to return to the factory setting. If you need to change the setting to the default setting, use "position --".

- Press **○** SET button. (Fixing of the lower limit position) ● Upper limit position and lower limit position are fixed, and the set positions are displayed for two seconds, then setting is completed. After the setting is completed, the louver which was set moves from the original position to the lower limit position, and goes back to the original position again. (This operation is not performed if the indoor unit and/or indoor unit fan is in operation.)

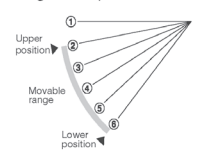

- Press **○** ON/OFF button. ● Louver adjusting mode ends and returns to the original display. *2

Caution
If the upper limit position number and the lower limit position number are set to the same position, the louver is fixed at that position auto swing does not function.

ATTENTION
If you press **RESET** button during settings, the display will return to previous display. If you press **ON/OFF** button during settings, the mode will be ended and return to original display, and the settings that have not been completed will become invalid.

When plural remote controllers are connected, louver setting operation cannot be set by slave remote controller.

*1. This function is not able to be set with wireless remote controls or simple remote control (RCH-H3).
*2. For setting the swing range of other louvers, return to 1 and proceed same procedure respectively.





(d) Duct connected-Low / Middle static pressure type (FDUM)

This manual is for the installation of an indoor unit.













Все каталоги и инструкции здесь: <http://splitoff.ru/tehn-doc.html>































(Outdoor) and refrigerant pipe work installation for outdoor unit, refer to the installation manual attached to an outdoor unit.

SAFETY PRECAUTIONS

- Read the "SAFETY PRECAUTIONS" carefully first of all and then strictly follow it during the installation work in order to protect yourself.
- The precautionary items mentioned below are distinguished into two levels, **WARNING** and **CAUTION**.
WARNING: Wrong installation would cause serious consequences such as injuries or death.
CAUTION: Wrong installation might cause serious consequences depending on circumstances.
 Both mentions the important items to protect your health and safety so strictly follow them by any means.
 The meanings of "Marks" used here are as shown on the right:
 Never do it under any circumstances.  Always do it according to the instruction.
- After completing the installation, do commissioning to confirm there are no abnormalities, and explain to the customers about "SAFETY PRECAUTIONS", correct operation method and maintenance method (air filter cleaning, operation method and temperature setting method) with user's manual of this unit.
 Ask your customers to keep this installation manual together with the user's manual. Also, ask them to hand over the user's manual to the new user when the owner is changed.

WARNING

- **Installation should be performed by the specialist.** 
 If you install the unit by yourself, it may lead to serious trouble such as water leakage, electric shock, fire, and injury due to overturn of the unit.
- **Install the system correctly according to these installation manuals.** 
 Improper installation may cause explosion, injury, water leakage, electric shock, and fire.
- **Check the density referred by the formula (accordance with ISO5149).** 
 If the density exceeds the limit density, please consult the dealer and installate the ventilation system.
- **Use the genuine accessories and the specified parts for installation.** 
 If parts unspecified by our company are used it could cause water leakage, electric shock, fire, and injury due to overturn of the unit.
- **Ventilate the working area well in case the refrigerant leaks during installation.** 
 If the refrigerant contacts the fire, toxic gas is produced.
- **Install the unit in a location that can hold heavy weight.** 
 Improper installation may cause the unit to fall leading to accidents.
- **Install the unit properly in order to be able to withstand strong winds such as typhoons, and earthquakes.** 
 Improper installation may cause the unit to fall leading to accidents.
- **Do not mix air in to the cooling cycle on installation or removal of the air conditioner.** 
 If air is mixed in, the pressure in the cooling cycle will rise abnormally and may cause explosion and injuries.
- **Be sure to have the electrical wiring work done by qualified electrical installer, and use exclusive circuit.** 
 Power source with insufficient capacity and improper work can cause electric shock and fire.
- **Use specified wire for electrical wiring, fasten the wiring to the terminal securely, and hold the cable securely in order not to apply unexpected stress on the terminal.** 
 Loose connections or hold could result in abnormal heat generation or fire.
- **Arrange the electrical wires in the control box properly to prevent them from rising. Fit the lid of the services panel properly.** 
 Improper fitting may cause abnormal heat and fire.
- **Check for refrigerant gas leakage after installation is completed.** 
 If the refrigerant gas leaks into the house and comes in contact with a fan heater, a stove, or an oven, toxic gas is produced.
- **Use the specified pipe, flare nut, and tools for R410A.** 
 Using existing parts (R22) could cause the unit failure and serious accident due to explosion of the cooling cycle.
- **Tighten the flare nut according to the specified method by with torque wrench.** 
 If the flare nut were tightened with excess torque, it could cause burst and refrigerant leakage after a long period.
- **Do not put the drainage pipe directly into drainage channels where poisonous gases such as sulfide gas can occur.** 
 Poisonous gases will flow into the room through drainage pipe and seriously affect the user's health and safety. This can also cause the corrosion of the indoor unit and a resultant unit failure or refrigerant leak.
- **Connect the pipes for refrigeration circuit securely in installation work before compressor is operated.** 
 If the compressor is operated when the service valve is open without connecting the pipe, it could cause explosion and injuries due to abnormal high pressure in the system.
- **Stop the compressor before removing the pipe after shutting the service valve on pump down work.** 
 If the pipe is removed when the compressor is in operation with the service valve open, air would be mixed in the refrigeration circuit and it could cause explosion and injuries due to abnormal high pressure in the cooling cycle.
- **Only use prescribed optional parts. The installation must be carried out by the qualified installer.** 
 If you install the system by yourself, it can cause serious trouble such as water leaks, electric shocks, fire.
- **Do not repair by yourself. And consult with the dealer about repair.** 
 Improper repair may cause water leakage, electric shock or fire.
- **Consult the dealer or a specialist about removal of the air conditioner.** 
 Improper installation may cause water leakage, electric shock or fire.
- **Turn off the power source during servicing or inspection work.** 
 If the power is supplied during servicing or inspection work, it could cause electric shock and injury by the operating fan.
- **Do not run the unit when the panel or protection guard are taken off.** 
 Touching the rotating equipment, hot surface, or high voltage section could cause an injury to be caught in the machine, to get burned, or electric shock.
- **Shut off the power before electrical wiring work.** 
 It could cause electric shock, unit failure and improper running.

- **Do not connect the earth wiring to the gas pipe, water pipe, lightning rod and telephone earth wiring. Improper earth could cause unit failure and electric shock due to a short circuit.** 
- **Earth leakage breaker must be installed.** 
 If the earth leakage breaker is not installed, it can cause electric shocks.
- **Use the circuit breaker of correct capacity. Circuit breaker should be the one that disconnect all poles under over current.** 
 Using the incorrect one could cause the system failure and fire.
- **Do not use any materials other than a fuse of correct capacity where a fuse should be used.** 
 Connecting the circuit by wire or copper wire could cause unit failure and fire.
- **Do not install the indoor unit near the location where there is possibility of flammable gas leakages.** 
 If the gas leaks and gathers around the unit, it could cause fire.
- **Do not install and use the unit where corrosive gas (such as sulfurous acid gas etc.) or flammable gas (such as thinner, petroleum etc.) may be generated or accumulated, or volatile flammable substances are handled.** 
 It could cause the corrosion of heat exchanger, breakage of plastic parts etc. And inflammable gas could cause fire.
- **Secure a space for installation, inspection and maintenance specified in the manual.** 
 Insufficient space can result in accident such as personal injury due to falling from the installation place.
- **Do not use the indoor unit at the place where water splashes such as laundry.** 
 Indoor unit is not waterproof. It could cause electric shock and fire.
- **Do not use the indoor unit for a special purpose such as food storage, cooling for precision instrument, preservation of animals, plants, and a work of art.** 
 It could cause the damage of the items.
- **Do not install nor use the system near equipments which generate electromagnetic wave or high harmonics.** 
 Equipments like inverter equipment, private power generator, high-frequency medical equipment, or telecommunication equipment might influence the air conditioner and cause a malfunction and breakdown. Or the air conditioner might influence medical equipments or telecommunication equipments, and obstruct their medical activity or cause jamming.
- **Do not install the remote controller at the direct sunlight.** 
 It could cause breakdown or deformation of the remote controller.
- **Do not install the indoor unit at the place listed below.** 
 - Places where flammable gas could leak.
 - Places where carbon fiber, metal powder or any powder is floated.
 - Place where the substances which affect the air conditioner are generated such as sulfide gas, chloride gas, acid, alkali or ammoniac atmospheres.
 - Places exposed to oil mist or steam directly.
 - On vehicles and ships
 - Places where machinery which generates high harmonics is used.
 - Places where cosmetics or special sprays are frequently used.
 - Highly salted area such as beach.
 - Heavy snow area
 - Places where the system is affected by smoke from a chimney.
 - Altitude over 1000m
- **Do not install the indoor unit in the locations listed below (Be sure to install the indoor unit according to the installation manual for each model because each indoor unit has each limitation)** 
 - Locations with any obstacles which can prevent inlet and outlet air of the unit.
 - Locations where vibration can be amplified due to insufficient strength of structure.
 - Locations where the infrared receiver is exposed to the direct sunlight or the strong light beam. (in case of the infrared specification unit)
 - Locations where an equipment affected by high harmonics is placed. (TV set or radio receiver is placed within 5m)
 - Locations where drainage cannot run off safely.
 It can affect performance or function and etc..
- **Do not put any valuables which will break down by getting wet under the air conditioner.** 
 Condensation could drop when the relative humidity is higher than 80% or drain pipe is clogged, and it damages user's belongings.
- **Do not use the base frame for the outdoor unit which is corroded or damaged after a long period of use.** 
 It could cause the unit falling down and injury.
- **Pay attention not to damage the drain pan by weld sputter when brazing work is done near the unit.** 
 If sputter entered into the unit during brazing work, it could cause damage (pinhole) of drain pan and leakage of water. To avoid damaging, keep the indoor unit packed or cover the indoor unit.
- **Install the drain pipe to drain the water surely according to the installation manual.** 
 Improper connection of the drain pipe may cause dropping water into room and damaging user's belongings.
- **Do not share the drain pipe for indoor unit and GHP (Gas Heat Pump system) outdoor unit.** 
 Toxic exhaust gas would flow into room and it might cause serious damage (some poisoning or deficiency of oxygen) to user's health and safety.
- **Be sure to perform air tightness test by pressurizing with nitrogen gas after completed refrigerant piping work.** 
 If the density of refrigerant exceeds the limit in the event of refrigerant leakage in the small room, lack of oxygen can occur, which can cause serious accidents.
- **For drain pipe installation, be sure to make descending slope of greater than 1/100, not to make traps, and not to make air-bleeding.** 
 Check if the drainage is correctly done during commissioning and ensure the space for inspection and maintenance.
- **Ensure the insulation on the pipes for refrigeration circuit so as not to condense water.** 
 Incomplete insulation could cause condensation and it would wet ceiling, floor, and any other valuables.
- **Do not install the outdoor unit where is likely to be a nest for insects and small animals.** 
 Insects and small animals could come into the electronic components and cause breakdown and fire. Instruct the user to keep the surroundings clean.
- **Pay extra attention, carrying the unit by hand.** 
 Carry the unit with 2 people if it is heavier than 20kg. Do not use the plastic straps but the grabbing place, moving the unit by hand. Use protective gloves in order to avoid injury by the aluminum fin.
- **Make sure to dispose of the packaging material.** 
 Leaving the materials may cause injury as metals like nail and woods are used in the package.
- **Do not operate the system without the air filter.** 
 It may cause the breakdown of the system due to clogging of the heat exchanger.
- **Do not touch any button with wet hands.** 
 It could cause electric shock.
- **Do not touch the refrigerant piping with bare hands when in operation.** 
 The pipe during operation would become very hot or cold according to the operating condition, and it could cause a burn or frostbite.
- **Do not clean up the air conditioner with water.** 
 It could cause electric shock.
- **Do not turn off the power source immediately after stopping the operation.** 
 Be sure to wait for more than 5 minutes. Otherwise it could cause water leakage or breakdown.
- **Do not control the operation with the circuit breaker.** 
 It could cause fire or water leakage. In addition, the fan may start operation unexpectedly and it may cause injury.

○ This model is middle static ducted type air conditioning unit. Therefore, do not use this model for direct blow type air conditioning unit.

Все каталоги и инструкции здесь: <http://splitoff.ru/tehn-doc.html>

● Confirm the following points.

- Unit type/Power supply specification
- Pipes/Wires/Small parts
- Accessory items

Accessory item

For refrigerant pipe			For drain pipe			
Pipe cover (big)	Pipe cover (small)	Strap	Pipe cover (big)	Pipe cover (small)	Drain hose	Hose clamp
1	1	4	1	1	1	1
For heat insulation of gas pipe	For heat insulation of liquid tube	For pipe cover fixing	For heat insulation of drain socket	For heat insulation of drain socket	For drain pipe connecting	For drain hose mounting

Accessory parts are stored inside this suction side.

② Selection of installation location for the indoor unit

- Select the suitable areas to install the unit under approval of the user.
 - Areas where the indoor unit can deliver hot and cold wind sufficiently. Suggest to the user to use a circulator if the ceiling height is over 3m to avoid warm air being accumulated on the ceiling.
 - Areas where there is enough space to install and service.
 - Areas where it can be drained properly. Areas where drain pipe descending slope can be taken.
 - Areas where there is no obstruction of airflow on both air return grille and air supply port.
 - Areas where fire alarm will not be accidentally activated by the air conditioner.
 - Areas where the supply air does not short-circuit.
 - Areas where it is not influenced by draft air.
 - Areas not exposed to direct sunlight.
 - Areas where dew point is lower than around 28°C and relative humidity is lower than 80%.

This indoor unit is tested under the condition of JIS (Japan Industrial Standard) high humidity condition and confirmed there is no problem. However, there is some risk of condensation drop if the air conditioner is operated under the severer condition than mentioned above.

If there is a possibility to use it under such a condition, attach additional insulation of 10 to 20mm thick for entire surface of indoor unit, refrigeration pipe and drain pipe.

- Areas where TV and radio stays away more than 1m. (It could cause jamming and noise.)
- Areas where any items which will be damaged by getting wet are not placed such as food, table wares, server, or medical equipment under the unit.
- Areas where there is no influence by the heat which cookware generates.
- Areas where not exposed to oil mist, powder and/or steam directly such as above fryer.
- Areas where lighting device such as fluorescent light or incandescent light doesn't affect the operation.

(A beam from lighting device sometimes affects the infrared receiver for the wireless remote controller and the air conditioner might not work properly.)

- Check if the place where the air conditioner is installed can hold the weight of the unit. If it is not able to hold, reinforce the structure with boards and beams strong enough to hold it. If the strength is not enough, it could cause injury due to unit falling.

Space for installation and service

- Make installation altitude over 2.5m.

(Indoor Unit)

Installation Space

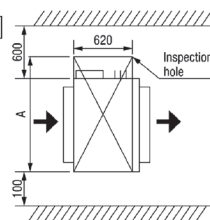

	UNIT: mm		
Multi type	22-56	71, 90	112, 140
Single type	50	60, 71	100-140
A	1100	1300	1720

③ Preparation before installation

- If suspension bolt becomes longer, do reinforcement of earthquake resistant.
- For grid ceiling
 - When the suspension bolt length is over 500mm, or the gap between the ceiling and roof is over 700mm, apply earthquake resistant brace to the bolt.
 - In case the unit is hanged directly from the slab and is installed on the ceiling plane which has enough strength.
 - When suspension bolt length is over 1000mm, apply the earthquake resistant brace to the bolt.
- Prepare four (4) sets of suspension bolt, nut and spring washer (M10) on site.

Suspension Bolt Location

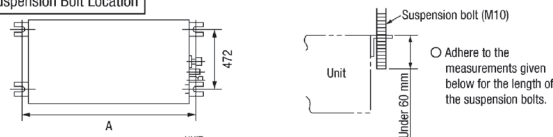

	UNIT: mm		
Multi type	22-56	71, 90	112, 140
Single type	50	60, 71	100-140
A	786	986	1406

③ Preparation before installation (continued)

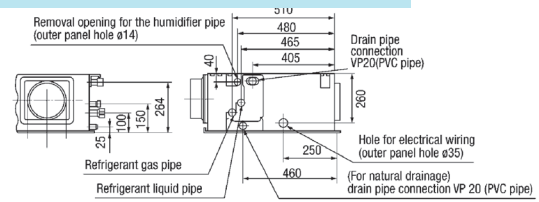

Multi type	112, 140
Single type	100-140

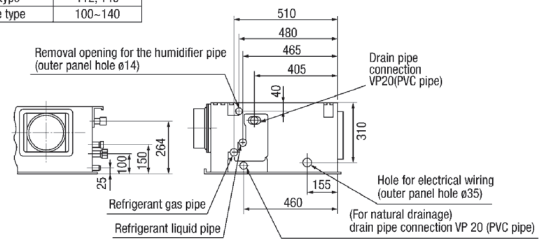

④ Installation of indoor unit

Installation

- [Hanging]
Hang the unit up.



If the measurements between the unit and the ceiling hole do not match upon installation, it may be adjusted with the long holed installation tool.

Adjustment for horizontality

- Either use a level vial, or adjust the level according to the method below.

- Adjust so the bottom side of the unit will be leveled with the water surface as illustrated below.

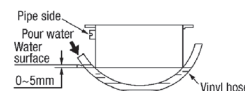

- If the unit is not leveled, it may cause malfunctions or inoperation of the float switch.

⑤ Duct Work

- A corrugated board (for preventing sputtering) is attached to the main body of the air conditioner (on the outlet port). Do not remove it until connecting the duct.

- An air filter can be provided on the main body of the air conditioner (on the inlet port). Remove it when connecting the duct on the inlet port.

② Blowout duct

- Use according to the spot numbers shown in the table below with a 200 circular duct.

Multi type	22	36, 45, 56	71, 90	112, 140
Single type	-	50	56, 71	100-140
Spot numbers	1 spot	2 spots	3 or 2 spots	4 or 3 spots

- The difference of the duct lengths between each spot should be less than 2:1.
- The ducts should be at their minimum lengths.
- Keep the bends to a minimum. (The bending radius should be as large as possible.)

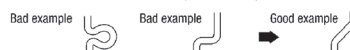

- Tie and secure the connection to the duct flange of the main unit/blowout hole with a band. Then, apply insulation materials to the secured part for dew condensation prevention.

- Use of the sound and heat insulated flexible duct is recommended for condensation prevention and soundproofing. (sold separately; 1m, 2m, 4m available)

- Conduct the duct work before ceiling attachment.

③ Inlet port

- When shipped the inlet port lies on the back.
- When connecting the duct to the inlet port, remove the air filter if it is fitted to the inlet port.

⑤ Duct Work (continued)

- When placing the inlet port to carry out suction from the bottom side, use the following procedure to replace the suction duct joint and the bottom plate.

- Remove the screws which fasten the bottom plate and the duct joint on the inlet port side of the unit.

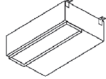

- Replace the removed bottom plate and duct joint.

- Fit the duct joint with a screw; fit the bottom plate.
 - Make sure to insulate the duct to prevent dewing on it.
- Install the specific blowout duct in a location where the air will circulate to the entire room.
 - The duct connection is specific to the 200 circular duct.
 - Conduct the installation of the specific blowout hole and the connection of the duct before attaching them to the ceiling.
 - Insulate the area where the duct is secured by a band for dew condensation prevention.

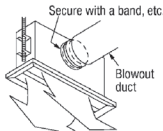

- Make sure provide an inspection hole on the ceiling. It is indispensable to service electric equipment, motor, functional components and cleaning of heat exchanger.

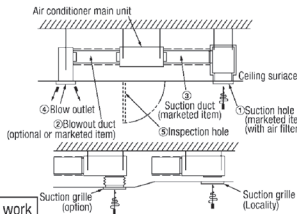

Bad example of duct work

- If a duct is not provided at the suction side but it is substituted with the space over the ceiling, humidity in the space will increase by the influence of capacity of ventilation fan, strength of wind blowing against the out door air louver, weather (rainy day) and others.
 - Moisture in air is likely to condense over the external plates of the unit and to drip on the ceiling. Unit should be operated under the conditions as listed in the above table and within the limitation of wind volume. When the building is a concrete structure, especially immediately after the construction, humidity tends to rise even if the space over the ceiling is not substituted in place of a duct. In such occasion, it is necessary to insulate the entire unit with glass wool (25mm). (Use a wire net or equivalent to hold the glass wool in place.)
 - It may run out the allowable limit of unit operation (Example: When outdoor air temperature is 35°C DB, suction air temperature is 27°C WB) and it could result in such troubles as compressor overload, etc.
 - There is a possibility that the blow air volume may exceed the allowable range of operation due to the capacity of ventilation fan or strength of wind blowing against external air louver so that drainage from the heat exchanger may fall to reach the drain pan but leak outside (Example: drip on to the ceiling) with consequential water leakage in the room.
- If vibration damping is not conducted between the unit and the duct, and between the unit and the slab, vibration will be transmitted to the duct and vibration noise may occur. Also, vibration may be transmitted from the unit to the slab. Vibration damping must be performed.

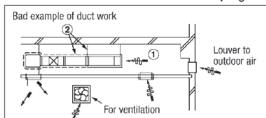

Notice

A specific cover plate is available when changing the 4 spot to the 3 spot, or when changing the 3 spot to the 2 spot.
 Note: Do not change from 2 spot to 1 spot.

Connecting the air intake/vent ducts

- Fresh Air Intake (for air intake duct only)
 - Use the side fresh air intake hole, or supply through a part of the suction duct.

- [for simultaneous air intake/vent]
- Intake air through the suction duct. (the side cannot be used)

- Air Vent
 - Use the side air vent hole. (always use together with the air intake)

- Use the duct flange for the air intake/vent (sold separately; for 125 circular duct connection), and connect the 125 circular duct (tighten with band).
- Insulate the duct to protect it from dew condensation.

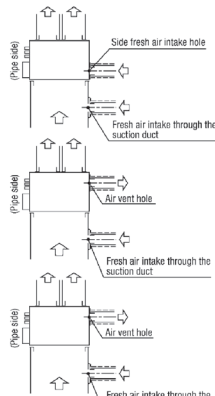

⑥ Refrigerant pipe

Caution

- Use the new refrigerant pipe. When you use the old pipe, please refer to the following items.
 - Do not use any refrigerant other than R410A.
 - Using other refrigerant except R410A (R22 etc.) may degrade inside refrigeration oil. And air getting into refrigeration circuit may cause over-pressure and resultant it may result in bursting, etc.
 - Store the copper pipes indoors and seal the both end of them until they are brazed in order to avoid any dust, dirt or water getting into pipe. Otherwise it will cause degradation of refrigeration oil and compressor breakdown, etc.
 - Use special tools for R410 refrigerant.

Piping work

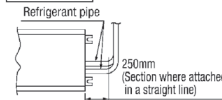

When conducting piping work, make sure to allow the pipes to be aligned in a straight line for at least 250 mm, as shown in the left illustration. (This is necessary for the drain pump to function)

Work procedure

- Remove the flare nut and blind flanges on the pipe of the indoor unit.
 - ※ Make sure to loosen the flare nut with holding the nut on pipe side with a spanner and giving torque to the nut with another spanner in order to avoid unexpected stress to the copper pipe, and then remove them. (Gas may come out at this time, but it is not abnormal.)
 - Pay attention whether the flare nut pops out. (as the indoor unit is sometimes pressured.)
- Make a flare on liquid pipe and gas pipe, and connect the refrigeration pipes on the indoor unit.
 - ※ Bend the pipe with as big radius as possible and do not bend the pipe repeatedly. In addition, do not twist and crush the pipes.
 - ※ Do a flare connection as follows:
 - Make sure to loosen the flare nut with holding the nut on pipe side with a spanner and giving torque to the nut with another spanner in order to avoid unexpected stress to the copper pipe, and then remove them.
 - When fastening the flare nut, align the refrigeration pipe with the center of flare nut, screw the nut for 3-4 times by hand and then tighten it by spanner with the specified torque mentioned in the table below. Make sure to hold the pipe on the indoor unit securely by a spanner when tightening the nut in order to avoid unexpected stress on the copper pipe.
- Cover the flare connection part of the indoor unit with attached insulation material after a gas leakage inspection, and tighten both ends with attached straps.
 - Make sure to insulate both gas pipes and liquid pipes completely.
 - ※ Incomplete insulation may cause dew condensation or water dropping.
- Refrigerant is charged in the outdoor unit. As for the additional refrigerant charge for the indoor unit and piping, refer to the installation manual attached to the outdoor unit.

Pipe diameter	Tightening torque N·m
φ 6.35	14 to 18
φ 9.52	34 to 42
φ 12.7	49 to 61
φ 15.88	68 to 82
φ 19.05	100 to 120

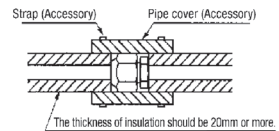

⑦ Drain pipe

Caution

- Install the drain pipe according to the installation manual in order to drain properly. Imperfection in draining may cause flood indoors and wetting the household goods, etc.
- Do not put the drain pipe directly into the ditch where toxic gas such as sulfur, the other harmful and inflammable gas is generated. Toxic gas would flow into the room and it would cause serious damage to user's health and safety (some poisoning or deficiency of oxygen). In addition, it may cause corrosion of heat exchanger and bad smell.
- Connect the pipe securely to avoid water leakage from the joint.
- Insulate the pipe properly to avoid condensation drop.
- Check if the water can flow out properly from both the drain outlet on the indoor unit and the end of the drain pipe after installation.
- Make sure to make descending slope of greater than 1/100 and do not make up-down bend and/or trap in the midway. In addition, do not put air vent on the drain pipe. Check if water is drained out properly from the pipe during commissioning. Also, keep sufficient space for inspection and maintenance.

Work procedure

- Make sure to insert the drain hose (the end mode of soft PVC) to the end of the step part of drain socket. Attach the hose clamp to the drain hose around 10mm from the end, and fasten the screw within 5mm left to the nut.
 - Do not apply adhesives on this end.
 - Do not use acetone-based adhesives to connect to the drain socket.

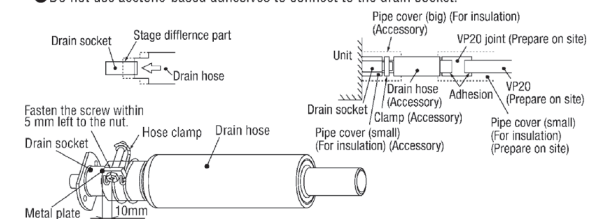

⑦ Drain pipe (continued)

2. Prepare a joint for connecting VP-20 pipe, adhere and connect the joint to the drain hose (the end made of rigid PVC), and adhere and connect VP-20 pipe (prepare on site).
※As for drain pipe, apply VP-20 made of rigid PVC which is on the market.

Все каталоги и инструкции здесь: <http://splitoff.ru/tehn-doc.html>

water leakage.

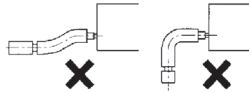

3. Make sure to make descending slope of greater than 1/100 and do not make up-down bend and/or trap in the midway.
 - Pay attention not to give stress on the pipe on the indoor unit side, and support and fix the pipe as close place to the unit as possible when connecting the drain pipe.
 - Do not set up air vent.

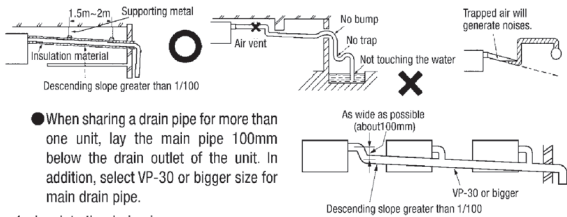

- When sharing a drain pipe for more than one unit, lay the main pipe 100mm below the drain outlet of the unit. In addition, select VP-30 or bigger size for main drain pipe.

4. Insulate the drain pipe.
 - Be sure to insulate the drain socket and rigid PVC pipe installed indoors otherwise it may cause dew condensation and water leakage.
 - ※ After drainage test implementation, cover the drain socket part with pipe cover (small size), then use the pipe cover (big size) to cover the pipe cover (small size), clamps and part of the drain hose, and fix and wrap it with tapes to wrap and make joint part gapless.

Drain up

- The position for drain pipe outlet can be raised up to 600mm above the ceiling. Use elbows for installation to avoid obstacles inside ceiling. If the horizontal drain pipe is too long before vertical pipe, the backflow of water will increase when the unit is stopped, and it may cause overflow of water from the drain pan on the indoor unit. In order to avoid overflow, keep the horizontal pipe length and offset of the pipe within the limit shown in the figure below.

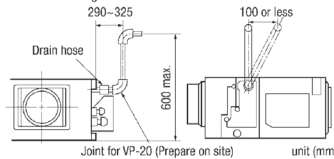

Otherwise, the construction point makes it same as drain pipe construction.

Drain test

1. Conduct a drain test after completion of the electrical work.
2. During the trail, make sure that drain flows properly through the piping and that no water leaks from connections.
3. In case of a new building, conduct the test before it is furnished with the ceiling.
4. Be sure to conduct this test even when the unit is installed in the heating season.

Procedures

1. Supply about 1000 cc of water to the unit through the air outlet by using a feed water pump.
2. Check the drain while cooling operation.

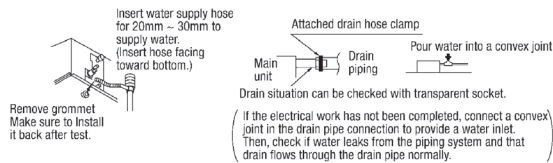

Outline of bottom drain piping work

- If the bottom drain piping can be done with a descending gradient (1/50-1/100), it is possible to connect the pipes as shown in the drawing below.

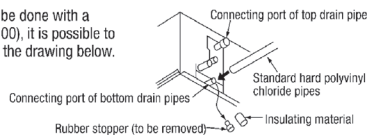

Uncoupling the drain motor connector

- Uncouple the connector CNR for the drain motor as illustrated in the drawing on the right.

(Note: If the unit is run with the connector coupled, drain water will be discharged from the upper drain pipe joint, causing a water leak.)

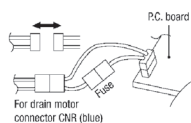

⑦ Drain pipe (continued)

Drain pump operation

- In case electrical wiring work finished

○ In case electrical wiring work not finished

Drain pump will run continuously when the dip switch "SW7-1" on the indoor unit PCB is turned ON, the Connector CNB is disconnected, and then the power supply (230VAC on the terminal block ① and ②) is turned ON. Make sure to turn OFF "SW7-1" and reconnect the Connector CNB after the test.

⑧ Wiring-out position and wiring connection

- Electrical installation work must be performed according to the installation manual by an electrical installation service provider qualified by a power provider of the country, and be executed according to the technical standards and other regulations applicable to electrical installation in the country.
- Be sure to use an exclusive circuit.
- Use specified cord, fasten the wiring to the terminal securely, and hold the cord securely in order not to apply unexpected stress on the terminal.
- Do not put both power source line and signal line on the same route. It may cause miscommunication and malfunction.
- Be sure to do D type earth work.
- For the details of electrical wiring work, see attached instruction manual for electrical wiring work.

1. Remove a lid of the control box (2 screws).
2. Hold each wiring inside the unit and fasten them to terminal block securely.
3. Fix the wiring with clamps.
4. Install the removed parts back to original place.

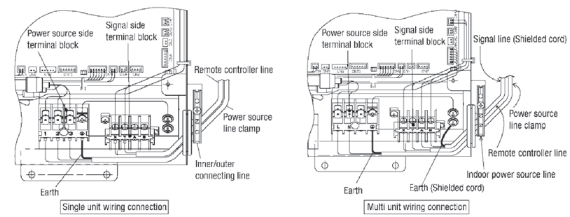

⑨ Check list after installation

- Check the following items after all installation work completed.

Check if	Expected trouble	Check
The indoor and outdoor units are fixed securely?	Falling, vibration, noise	
Inspection for leakage is done?	Insufficient capacity	
Insulation work is properly done?	Water leakage	
Water is drained properly?	Water leakage	
Supply voltage is same as mentioned in the model name plate?	PCB burnt out, not working at all	
There is mis-wiring or mis-connection of piping?	PCB burnt out, not working at all	
Earth wiring is connected properly?	Electric shock	
Cable size comply with specified size?	PCB burnt out, not working at all	
Any obstacle blocks airflow on air inlet and outlet?	Insufficient capacity	

⑩ Tap selection on blower unit (when the high performance filter is used)

Following table shows the maximum external static pressure for models adapted to the fan setting speed (Hi, UH). Select at site the fan setting speed according to the external static pressure.

		50/60Hz		
		22-56	71, 90, 140	112
Multi type				
Single type		50	60, 71, 125, 140	100
Fan Speed	Hi	60/60	60/60	60/60
	UH	85/90	85/100	90/100

Unit:Pa

⚠ CAUTION

- Taps should not be used under external static pressure mentioned above.
- Dew condensation may occur with the unit and wet the ceiling or furniture.
- Do not use under external static pressure of 60Pa or less. Water drops may be blown from the diffuser outlet of the unit and wet the ceiling or furniture.

(e) Duct connected-High static pressure type (FDU)







1) Models FDU71 ~ 140

This manual is for the installation of an indoor unit.























Все каталоги и инструкции здесь: <http://splitoff.ru/tehn-doc.html>































(Outdoor) and refrigerant pipe work installation for outdoor unit, refer to the installation manual attached to an outdoor unit.

SAFETY PRECAUTIONS

- Read the "SAFETY PRECAUTIONS" carefully first of all and then strictly follow it during the installation work in order to protect yourself.
- The precautionary items mentioned below are distinguished into two levels.  **WARNING** and  **CAUTION**.
 **WARNING**: Wrong installation would cause serious consequences such as injuries or death.
 **CAUTION**: Wrong installation might cause serious consequences depending on circumstances. Both mentions the important items to protect your health and safety so strictly follow them by any means.
- The meanings of "Marks" used here are as shown on the right.
 Never do it under any circumstances.  Always do it according to the instruction.
- After completing the installation, do commissioning to confirm there are no abnormalities, and explain to the customers about "SAFETY PRECAUTIONS", correct operation method and maintenance method (air filter cleaning, operation method and temperature setting method) with user's manual of this unit. Ask your customers to keep this installation manual together with the user's manual. Also, ask them to hand over the user's manual to the new user when the operation is changed.

 **WARNING**

- **Installation should be performed by the specialist.** 
If you install the unit by yourself, it may lead to serious trouble such as water leakage, electric shock, fire, and injury due to overturn of the unit.
- **Install the system correctly according to these installation manuals.** 
Improper installation may cause explosion, injury, water leakage, electric shock, and fire.
- **Check the density referred by the formula (accordance with ISO5149).** 
If the density exceeds the limit density, please consult the dealer and installate the ventilation system.
- **Use the genuine accessories and the specified parts for installation.** 
If parts unspecified by our company are used, it could cause water leakage, electric shock, fire, and injury due to overturn of the unit.
- **Ventilate the working area well in case the refrigerant leaks during installation.** 
If the refrigerant contacts the fire, toxic gas is produced.
- **Install the unit in a location that can hold heavy weight.** 
Improper installation may cause the unit to fall leading to accidents.
- **Install the unit properly in order to be able to withstand strong winds such as typhoons, and earthquakes.** 
Improper installation may cause the unit to fall leading to accidents.
- **Do not mix air in to the cooling cycle on installation or removal of the air conditioner.** 
If air is mixed in, the pressure in the cooling cycle will rise abnormally and may cause explosion and injuries.
- **Be sure to have the electrical wiring work done by qualified electrical installer, and use exclusive circuit.** 
Power source with insufficient capacity and improper work can cause electric shock and fire.
- **Use specified wire for electrical wiring, fasten the wiring to the terminal securely, and hold the cable securely in order not to apply unexpected stress on the terminal.** 
Loose connections or hold could result in abnormal heat generation or fire.
- **Arrange the electrical wires in the control box properly to prevent them from rising. Fit the lid of the services panel properly.** 
Improper fitting may cause abnormal heat and fire.
- **Check for refrigerant gas leakage after installation is completed.** 
If the refrigerant gas leaks into the house and comes in contact with a fan heater, a stove, or an oven, toxic gas is produced.
- **Use the specified pipe, flare nut, and tools for R410A.** 
Using existing parts (R22) could cause the unit failure and serious accident due to explosion of the cooling cycle.
- **Tighten the flare nut according to the specified method by with torque wrench.** 
If the flare nut were tightened with excess torque, it could cause burst and refrigerant leakage after a long period.
- **Do not put the drainage pipe directly into drainage channels where poisonous gases such as sulfide gas can occur.** 
Poisonous gases will flow into the room through drainage pipe and seriously affect the user's health and safety. This can also cause the corrosion of the indoor unit and a resultant unit failure or refrigerant leak.
- **Connect the pipes for refrigeration circuit securely in installation work before compressor is operated.** 
If the compressor is operated when the service valve is open without connecting the pipe, it could cause explosion and injuries due to abnormal high pressure in the system.
- **Stop the compressor before removing the pipe after shutting the service valve on pump down work.** 
If the pipe is removed when the compressor is in operation with the service valve open, air would be mixed in the refrigeration circuit and it could cause explosion and injuries due to abnormal high pressure in the cooling cycle.
- **Only use prescribed optional parts. The installation must be carried out by the qualified installer.** 
If you install the system by yourself, it can cause serious trouble such as water leaks, electric shocks, fire.
- **Do not repair by yourself. And consult with the dealer about repair.** 
Improper repair may cause water leakage, electric shock or fire.
- **Consult the dealer or a specialist about removal of the air conditioner.** 
Improper installation may cause water leakage, electric shock or fire.
- **Turn off the power source during servicing or inspection work.** 
If the power is supplied during servicing or inspection work, it could cause electric shock and injury by the operating fan.
- **Do not run the unit when the panel or protection guard are taken off.** 
Touching the rotating equipment, hot surface, or high voltage section could cause an injury to be caught in the machine, to get burned, or electric shock.
- **Shut off the power before electrical wiring work.** 
It could cause electric shock, unit failure and improper running.

- **Do not connect the earth wiring to the gas pipe, water pipe, lightning rod and telephone earth wiring. Improper earth could cause unit failure and electric shock due to a short circuit.** 
- **Earth leakage breaker must be installed.** 
If the earth leakage breaker is not installed, it can cause electric shocks.
- **Use the circuit breaker of correct capacity. Circuit breaker should be the one that disconnect all poles under over current.** 
Using the incorrect one could cause the system failure and fire.
- **Do not use any materials other than a fuse of correct capacity where a fuse should be used.** 
Connecting the circuit by wire or copper wire could cause unit failure and fire.
- **Do not install the indoor unit near the location where there is possibility of flammable gas leakages.** 
If the gas leaks and gathers around the unit, it could cause fire.
- **Do not install and use the unit where corrosive gas (such as sulfuric acid gas etc.) or flammable gas (such as thinner, petroleum etc.) may be generated or accumulated, or volatile flammable substances are handled.** 
It could cause the corrosion of heat exchanger, breakage of plastic parts etc. And inflammable gas could cause fire.
- **Secure a space for installation, inspection and maintenance specified in the manual.** 
Insufficient space can result in accident such as personal injury due to falling from the installation place.
- **Do not use the indoor unit at the place where water splashes such as laundry.** 
Indoor unit is not waterproof. It could cause electric shock and fire.
- **Do not use the indoor unit for a special purpose such as food storage, cooling for precision instrument, preservation of animals, plants, and a work of art.** 
It could cause the damage of the items.
- **Do not install nor use the system near equipments which generate electromagnetic wave or high harmonics.** 
Equipments like inverter equipment, private power generator, high-frequency medical equipment, or telecommunication equipment might influence the air conditioner and cause a malfunction and breakdown. Or the air conditioner might influence medical equipments or telecommunication equipments, and obstruct their medical activity or cause jamming.
- **Do not install the remote controller at the direct sunlight.** 
It could cause breakdown or deformation of the remote controller.
- **Do not install the indoor unit at the place listed below.** 
 - Places where flammable gas could leak.
 - Places where carbon fiber, metal powder or any powder is floated.
 - Place where the substances which affect the air conditioner are generated such as sulfide gas, chloride gas, acid, alkali or ammoniac atmospheres.
 - Places exposed to oil mist or steam directly.
 - On vehicles and ships
 - Places where machinery which generates high harmonics is used.
 - Places where cosmetics or special sprays are frequently used.
 - Highly salted area such as beach.
 - Heavy snow area
 - Places where the system is affected by smoke from a chimney.
 - Altitude over 1000m
- **Do not install the indoor unit in the locations listed below (Be sure to install the indoor unit according to the installation manual for each model because each indoor unit has each limitation)** 
 - Locations with any obstacles which can prevent inlet and outlet air of the unit.
 - Locations where vibration can be amplified due to insufficient strength of structure.
 - Locations where the infrared receiver is exposed to the direct sunlight or the strong light beam. (in case of the infrared specification unit)
 - Locations where an equipment affected by high harmonics is placed. (TV set or radio receiver is placed within 5m)
 - Locations where drainage cannot run off safely.
 It can affect performance or function and etc.
- **Do not put any valuables which will break down by getting wet under the air conditioner.** 
Condensation could drop when the relative humidity is higher than 80% or drain pipe is clogged, and it damages user's belongings.
- **Do not use the base frame for the outdoor unit which is corroded or damaged after a long period of use.** 
It could cause the unit falling down and injury.
- **Pay attention not to damage the drain pan by weld sputter when brazing work is done near the unit.** 
If sputter entered into the unit during brazing work, it could cause damage (pinhole) of drain pan and leakage of water. To avoid damaging, keep the indoor unit packed or cover the indoor unit.
- **Install the drain pipe to drain the water surely according to the installation manual.** 
Improper connection of the drain pipe may cause dropping water into room and damaging user's belongings.
- **Do not share the drain pipe for indoor unit and GHP (Gas Heat Pump system) outdoor unit.** 
Toxic exhaust gas would flow into room and it might cause serious damage (some poisoning or deficiency of oxygen) to user's health and safety.
- **Be sure to perform air tightness test by pressurizing with nitrogen gas after completed refrigerant piping work.** 
If the density of refrigerant exceeds the limit in the event of refrigerant leakage in the small room, lack of oxygen can occur, which can cause serious accidents.
- **For drain pipe installation, be sure to make descending slope of greater than 1/100, not to make traps, and not to make air-bleeding.** 
Check if the drainage is correctly done during commissioning and ensure the space for inspection and maintenance.
- **Ensure the insulation on the pipes for refrigeration circuit so as not to condense water.** 
Incomplete insulation could cause condensation and it would wet ceiling, floor, and any other valuables.
- **Do not install the outdoor unit where is likely to be a nest for insects and small animals.** 
Insects and small animals could come into the electronic components and cause breakdown and fire. Instruct the user to keep the surroundings clean.
- **Pay extra attention, carrying the unit by hand.** 
Carry the unit with 2 people if it is heavier than 20kg. Do not use the plastic straps but the grabbing place, moving the unit by hand. Use protective gloves in order to avoid injury by the aluminum fin.
- **Make sure to dispose of the packaging material.** 
Leaving the materials may cause injury as metals like nail and woods are used in the package.
- **Do not operate the system without the air filter.** 
It may cause the breakdown of the system due to clogging of the heat exchanger.
- **Do not touch any button with wet hands.** 
It could cause electric shock.
- **Do not touch the refrigerant piping with bare hands when in operation.** 
The pipe during operation would become very hot or cold according to the operating condition, and it could cause a burn or frostbite.
- **Do not clean up the air conditioner with water.** 
It could cause electric shock.
- **Do not turn off the power source immediately after stopping the operation.** 
Be sure to wait for more than 5 minutes. Otherwise it could cause water leakage or breakdown.
- **Do not control the operation with the circuit breaker.** 
It could cause fire or water leakage. In addition, the fan may start operation unexpectedly and it may cause injury.

○ This model is middle static ducted type air conditioning unit. Therefore, do not use this model for direct blow type air conditioning unit.

Все каталоги и инструкции здесь: <http://splitoff.ru/tehn-doc.html>

Summarize the following points.

- Unit type/Power supply specification
- Pipes/Wires/Small parts
- Accessory items

Accessory item

For refrigerant pipe		
Pipe cover (big)	Pipe cover (small)	Strap
1	1	4
For heat insulation of gas pipe	For heat insulation of liquid tube	For pipe cover fixing

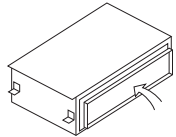

Accessory parts are stored inside this suction side.

For drain pipe			
Pipe cover (big)	Pipe cover (small)	Drain hose	Hose clamp
1	1	1	1
For heat insulation of drain socket	For heat insulation of drain socket	For drain pipe connecting	For drain hose mounting

② Selection of installation location for the indoor unit

- ① Select the suitable areas to install the unit under approval of the user.
 - Areas where the indoor unit can deliver hot and cold wind sufficiently. Suggest to use a circulator if the ceiling height is over 3m to avoid warm air being accumulated on the ceiling.
 - Areas where there is enough space to install and service.
 - Areas where it can be drained properly. Areas where drain pipe descending slope can be taken.
 - Areas where there is no obstruction of airflow on both air return grille and air supply port.
 - Areas where fire alarm will not be accidentally activated by the air conditioner.
 - Areas where the supply air does not short-circuit.
 - Areas where it is not influenced by draft air.
 - Areas not exposed to direct sunlight.
 - Areas where dew point is lower than around 28°C and relative humidity is lower than 80%.
 (This indoor unit is tested under the condition of JIS (Japan Industrial Standard) high humidity condition and confirmed there is no problem. However, there is some risk of condensation drop if the air conditioner is operated under the severer condition than mentioned above.)
 If there is a possibility to use it under such a condition, attach additional insulation of 10 to 20mm thick for entire surface of indoor unit, refrigeration pipe and drain pipe.
 - Areas where TV and radio stays away more than 1m. (It could cause jamming and noise.)
 - Areas where any items which will be damaged by getting wet are not placed such as food, table wares, server, or medical equipment under the unit.
 - Areas where there is no influence by the heat which cookware generates.
 - Areas where not exposed to oil mist, powder and/or steam directly such as above fryer.
 - Areas where lighting device such as fluorescent light or incandescent light doesn't affect the operation.
 (A beam from lighting device sometimes affects the infrared receiver for the wireless remote controller and the air conditioner might not work properly.)

- ② Check if the place where the air conditioner is installed can hold the weight of the unit. If it is not able to hold, reinforce the structure with boards and beams strong enough to hold it. If the strength is not enough, it could cause injury due to unit falling.

Space for installation and service

- Make installation altitude over 2.5m. (Indoor Unit)

Installation Space

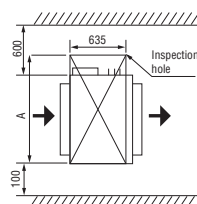

UNIT: mm		
Multi type	71	90, 112, 140
Single type	71	100, 125, 140
A	1200	1720

③ Preparation before installation

- If the ceiling is not earthquake resistant.
- If the ceiling is made of concrete, the ceiling and roof is over 700mm, apply earthquake resistant brace to the roof.
- In case the unit is hanged directly from the slab and is installed on the ceiling plane which has enough strength.
 When suspension bolt length is over 1000mm, apply the earthquake resistant brace to the bolt.
- Prepare four (4) sets of suspension bolt, nut and spring washer (M10) on site.

Suspension Bolt Location

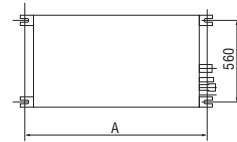

UNIT: mm		
Multi type	71	90, 112, 140
Single type	71	100, 125, 140
A	986	1406

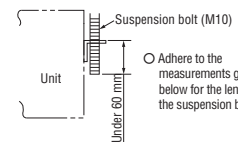

Pipe locations UNIT: mm

Multi type	71
Single type	71

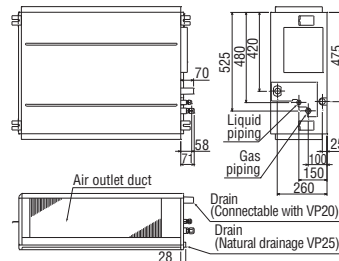

Multi type	90, 112, 140
Single type	100, 125, 140

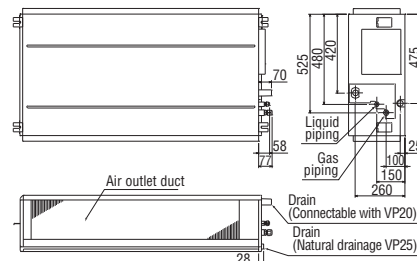

④ Installation of indoor unit

Installation

[Hanging]

Hang the unit up.

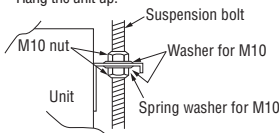

If the measurements between the unit and the ceiling hole do not match upon installation, it may be adjusted with the long holed installation tool.

Adjustment for horizontality

- Either use a level vial, or adjust the level according to the method below.

- Adjust so the bottom side of the unit will be leveled with the water surface as illustrated below.

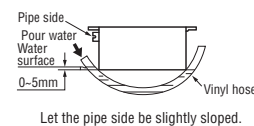



○ If the unit is not leveled, it may cause malfunctions or inoperation of the float switch.

⑤ Duct Work

A corrugated board (for preventing sputtering) is attached to the main body of the air conditioner (on the outlet port). Do not remove it until connecting the duct.

Все каталоги и инструкции здесь: <http://splitoff.ru/tehn-doc.html>

- The ducts should be at their minimum lengths.
 - Keep the bends to a minimum. (The bending radius should be as large as possible.)
- Bad example  Bad example  Good example 
- Conduct the duct work before ceiling attachment.
- ③ Suction duct
- Make sure to insulate the duct to prevent dewing on it.
- ④ Location and form of blow outlet should be selected so that air from the outlet will be distributed all over the room, and equipped with a device to control air volume.
- ⑤ Make sure provide an inspection hole on the ceiling. It is indispensable to service electric equipment, motor, functional components and cleaning of heat exchanger.

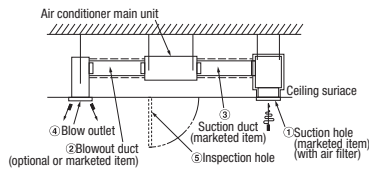

Bad example of duct work

- ① If a duct is not provided at the suction side but it is substituted with the space over the ceiling, humidity in the space will increase by the influence of capacity of ventilation fan, strength of wind blowing against the out door air louver, weather (rainy day) and others.
- a) Moisture in air is likely to condense over the external plates of the unit and to drip on the ceiling. Unit should be operated under the conditions as listed in the above table and within the limitation of wind volume. When the building is a concrete structure, especially immediately after the construction, humidity tends to rise even if the space over the ceiling is not substituted in place of a duct. In such occasion, it is necessary to insulate the entire unit with glass wool (25mm). (Use a wire net or equivalent to hold the glass wool in place.)
- b) It may run out the allowable limit of unit operation (Example: When outdoor air temperature is 35°C DB, suction air temperature is 27°C WB) and it could result in such troubles as compressor overload, etc..
- c) There is a possibility that the blow air volume may exceed the allowable range of operation due to the capacity of ventilation fan or strength of wind blowing against external air louver so that drainage from the heat exchanger may fall to reach the drain pan but leak outside (Example: drip on to the ceiling) with consequential water leakage in the room.
- ② If vibration damping is not conducted between the unit and the duct, and between the unit and the slab, vibration will be transmitted to the duct and vibration noise may occur. Also, vibration may be transmitted from the unit to the slab. Vibration damping must be performed.

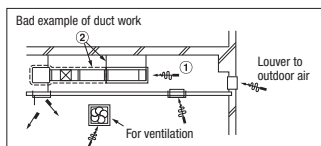

⑥ Refrigerant pipe

Caution

- Use the new refrigerant pipe. When re-using the existing pipe system for R22 or R407C, pay attention to the following items.
 - Change the flare nuts with the attached ones (JIS category 2), and reprocess the flare parts.
 - Do not use thin-walled pipes.
- Use phosphorus deoxidized copper alloy seamless pipe (C1220T specified in JIS H3300) for refrigeration pipe installation. In addition, make sure there is no damage both inside and outside of the pipe, and no harmful substances such as sulfur, oxide, dust or a contaminant stuck on the pipes.
- Do not use any refrigerant other than R410A. Using other refrigerant except R410A (R22 etc.) may degrade inside refrigeration oil. And air getting into refrigeration circuit may cause over-pressure and resultant it may result in bursting, etc.
- Store the copper pipes indoors and seal the both end of them until they are brazed in order to avoid any dust, dirt or water getting into pipe. Otherwise it will cause degradation of refrigeration oil and compressor breakdown, etc.
- Use special tools for R410 refrigerant.

Piping work

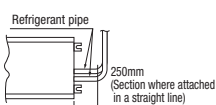

When conducting piping work, make sure to allow the pipes to be aligned in a straight line for at least 250 mm, as shown in the left illustration. (This is necessary for the drain pump to function)

⑥ Refrigerant pipe (continued)

Work procedure

1. Remove the flare nut and blind flanges on the pipe of the indoor unit.
 - Pay attention whether the flare nut pops out. (as the indoor unit is sometimes pressured.)
2. Make a flare on liquid pipe and gas pipe, and connect the refrigeration pipes on the indoor unit.
 - ※ Bend the pipe with as big radius as possible and do not bend the pipe repeatedly. In addition, do not twist and crush the pipes.
 - ※ Do a flare connection as follows:
 - Make sure to loosen the flare nut with holding the nut on pipe side with a spanner and giving torque to the nut with another spanner in order to avoid unexpected stress to the copper pipe, and then remove them.
 - When fastening the flare nut, align the refrigeration pipe with the center of flare nut, screw the nut for 3-4 times by hand and then tighten it by spanner with the specified torque mentioned in the table below. Make sure to hold the pipe on the indoor unit securely by a spanner when tightening the nut in order to avoid unexpected stress on the copper pipe.
3. Cover the flare connection part of the indoor unit with attached insulation material after a gas leakage inspection, and tighten both ends with attached straps.
 - Make sure to insulate both gas pipes and liquid pipes completely.
 - ※ Incomplete insulation may cause dew condensation or water dropping.
4. Refrigerant is charged in the outdoor unit. As for the additional refrigerant charge for the indoor unit and piping, refer to the installation manual attached to the outdoor unit.

Pipe diameter	Tightening torque N·m
φ 6.35	14 to 18
φ 9.52	34 to 42
φ 12.7	49 to 61
φ 15.88	68 to 82
φ 19.05	100 to 120

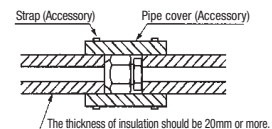

⑦ Drain pipe

Caution

- Install the drain pipe according to the installation manual in order to drain properly. Imperfection in draining may cause flood indoors and wetting the household goods, etc.
- Do not put the drain pipe directly into the ditch where toxic gas such as sulfur, the other harmful and inflammable gas is generated. Toxic gas would flow into the room and it would cause serious damage to user's health and safety (some poisoning or deficiency of oxygen). In addition, it may cause corrosion of heat exchanger and bad smell.
- Connect the pipe securely to avoid water leakage from the joint.
- Insulate the pipe properly to avoid condensation drop.
- Check if the water can flow out properly from both the drain outlet on the indoor unit and the end of the drain pipe after installation.
- Make sure to make descending slope of greater than 1/100 and do not make up-down bend and/or trap in the midway. In addition, do not put air vent on the drain pipe. Check if water is drained out properly from the pipe during commissioning. Also, keep sufficient space for inspection and maintenance.

Work procedure

1. Make sure to insert the drain hose (the end mode of soft PVC) to the end of the step part of drain socket. Attach the hose clamp to the drain hose around 10mm from the end, and fasten the screw within 5mm left to the nut.
 - Do not apply adhesives on this end.
 - Do not use acetone-based adhesives to connect to the drain socket.

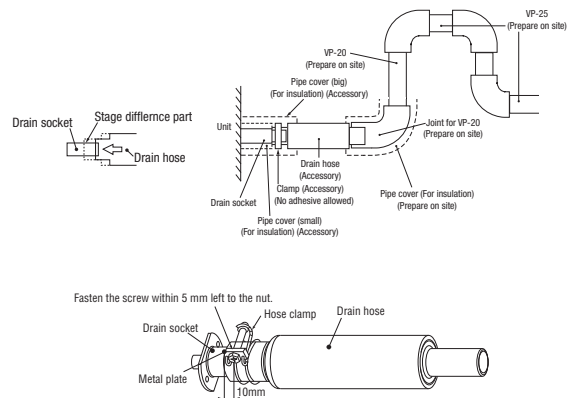

⑦ Drain pipe (continued)

2. Prepare a joint for connecting VP-20 pipe, adhere and connect the joint to the drain hose (the end made of rigid PVC), and adhere and connect VP-20 pipe (prepare on site).
 ※As for drain pipe, apply VP-20 made of rigid PVC which is on the market.

It may cause the flexible part broken after the adhesive is dried up and gets rigid.

- The flexible drain hose is intended to absorb a small difference at installation of the unit or drain pipes. Intentional bending, expanding may cause the flexible hose broken and water leakage.

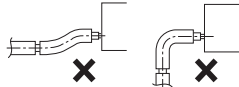

3. Make sure to make descending slope of greater than 1/100 and do not make up-down bend and/or trap in the midway.
 - Pay attention not to give stress on the pipe on the indoor unit side, and support and fix the pipe as close place to the unit as possible when connecting the drain pipe.
 - Do not set up air vent.

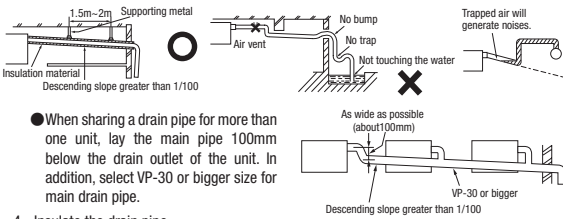

- When sharing a drain pipe for more than one unit, lay the main pipe 100mm below the drain outlet of the unit. In addition, select VP-30 or bigger size for main drain pipe.

4. Insulate the drain pipe.

- Be sure to insulate the drain socket and rigid PVC pipe installed indoors otherwise it may cause dew condensation and water leakage.
- ※ After drainage test implementation, cover the drain socket part with pipe cover (small size), then use the pipe cover (big size) to cover the pipe cover (small size), clamps and part of the drain hose, and fix and wrap it with tapes to wrap and make joint part gapless.

Drain up

- The position for drain pipe outlet can be raised up to 600mm above the ceiling. Use elbows for installation to avoid obstacles inside ceiling. If the horizontal drain pipe is too long before vertical pipe, the backflow of water will increase when the unit is stopped, and it may cause overflow of water from the drain pan on the indoor unit. In order to avoid overflow, keep the horizontal pipe length and offset of the pipe within the limit shown in the figure below.

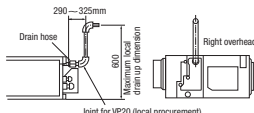

Otherwise, the construction point makes it same as drain pipe construction.

Drain test

1. Conduct a drain test after completion of the electrical work.
2. During the trial, make sure that drain flows properly through the piping and that no water leaks from connections.
3. In case of a new building, conduct the test before it is furnished with the ceiling.
4. Be sure to conduct this test even when the unit is installed in the heating season.

Procedures

1. Supply about 1000 cc of water to the unit through the air outlet by using a feed water pump.
2. Check the drain while cooling operation.

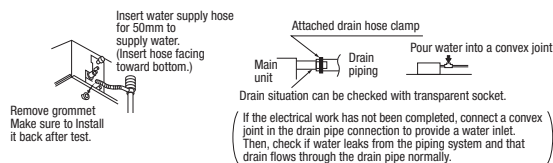

Outline of bottom drain piping work

- If the bottom drain piping can be done with a descending gradient (1/50-1/100), it is possible to connect the pipes as shown in the drawing below.

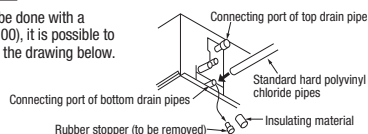

Uncoupling the drain motor connector

- Uncouple the connector CNR for the drain motor as illustrated in the drawing on the right.

(Note: If the unit is run with the connector coupled, drain water will be discharged from the upper drain pipe joint, causing a water leak.)

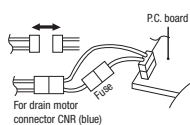

⑦ Drain pipe (continued)

Drain pump operation

- In case electrical wiring work finished

- In case electrical wiring work not finished

Drain pump will run continuously when the dip switch "SW7-1" on the indoor unit PCB is turned ON, the Connector CNB is disconnected, and then the power supply (230VAC on the terminal block ① and ②) is turned ON. Make sure to turn OFF "SW7-1" and reconnect the Connector CNB after the test.

⑧ Wiring-out position and wiring connection

- Electrical installation work must be performed according to the installation manual by an electrical installation service provider qualified by a power provider of the country, and be executed according to the technical standards and other regulations applicable to electrical installation in the country.
- Be sure to use an exclusive circuit.
- Use specified cord, fasten the wiring to the terminal securely, and hold the cord securely in order not to apply unexpected stress on the terminal.
- Do not put both power source line and signal line on the same route. It may cause miscommunication and malfunction.
- Be sure to do D type earth work.
- For the details of electrical wiring work, see attached instruction manual for electrical wiring work.

1. Remove a lid of the control box (2 screws).
2. Hold each wiring inside the unit and fasten them to terminal block securely.
3. Fix the wiring with clamps.
4. Install the removed parts back to original place.

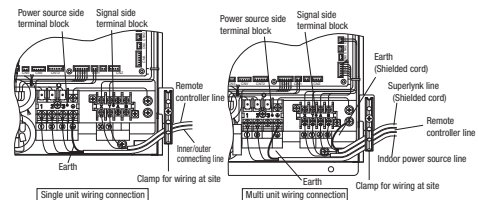

⑨ Check list after installation

- Check the following items after all installation work completed.

Check if	Expected trouble	Check
The indoor and outdoor units are fixed securely?	Falling, vibration, noise	
Inspection for leakage is done?	Insufficient capacity	
Insulation work is properly done?	Water leakage	
Water is drained properly?	Water leakage	
Supply voltage is same as mentioned in the model name plate?	PCB burnt out, not working at all	
There is mis-wiring or mis-connection of piping?	PCB burnt out, not working at all	
Earth wiring is connected properly?	Electric shock	
Cable size comply with specified size?	PCB burnt out, not working at all	
Any obstacle blocks airflow on air inlet and outlet?	Insufficient capacity	

⑩ Tap selection on blower unit (when the high performance filter is used)

The fan tap's factory setting is "Standard." If you want to change it to the high static-pressure setting, you can avail yourself of the following two methods. Use one of the two methods to set the fan tap. Make sure to perform the functional setting with remote controller.

Select [I/U FUNCTION] in the functional setting mode, and change the function number [02] [FAN SPEED SET].

For operation method, refer to the user's manual of the remote controller.

Function number A	Functional content B	Setting content C	Default setting
02	Fan Speed Set	Standard	○
		High Speed 1	

Static Pressure	UNIT: Pa	
	Standard Tap	High Speed 1 Tap
	60	130

⚠ CAUTION

If the external static pressure is 60Pa or less, do not set the fan speed to High speed 1. If high speed 1 setting is done, air outlet speed from indoor unit will increase and waterdrop may be blown out and wet the ceiling or the furniture.

Все каталоги и инструкции здесь: <http://splitoff.ru/tehn-doc.html>

n manual for wiring



2) Models FDU200, 250

This manual is for the installation of an indoor unit.























Все каталоги и инструкции здесь: <http://splitoff.ru/tehn-doc.html>































attached to an outdoor unit.

SAFETY PRECAUTIONS

- Read the "SAFETY PRECAUTIONS" carefully first of all and then strictly follow it during the installation work in order to protect yourself.
- The precautionary items mentioned below are distinguished into two levels, **⚠WARNING** and **⚠CAUTION**.
⚠WARNING: Wrong installation would cause serious consequences such as injuries or death.
⚠CAUTION: Wrong installation might cause serious consequences depending on circumstances.
 Both mentions the important items to protect your health and safety so strictly follow them by any means.
- The meanings of "Marks" used here are as shown on the right:
 Never do it under any circumstances.  Always do it according to the instruction.
- After completing the installation, do commissioning to confirm there are no abnormalities, and explain to the customers about "SAFETY PRECAUTIONS", correct operation method and maintenance method (air filter cleaning, operation method and temperature setting method) with user's manual of this unit. Ask your customers to keep this installation manual together with the user's manual. Also, ask them to hand over the user's manual to the new user when the owner is changed.

⚠ WARNING

- **Installation should be performed by the specialist.** 
If you install the unit by yourself, it may lead to serious trouble such as water leakage, electric shock, fire, and injury due to overturn of the unit.
- **Install the system correctly according to these installation manuals.** 
Improper installation may cause explosion, injury, water leakage, electric shock, and fire.
- **Check the density referred by the formula (accordance with ISO5149).** 
If the density exceeds the limit density, please consult the dealer and installate the ventilation system.
- **Use the genuine accessories and the specified parts for installation.** 
If parts unspecified by our company are used it could cause water leakage, electric shock, fire, and injury due to overturn of the unit.
- **Ventilate the working area well in case the refrigerant leaks during installation.** 
If the refrigerant contacts the fire, toxic gas is produced.
- **Install the unit in a location that can hold heavy weight.** 
Improper installation may cause the unit to fall leading to accidents.
- **Install the unit properly in order to be able to withstand strong winds such as typhoons, and earthquakes.** 
Improper installation may cause the unit to fall leading to accidents.
- **Do not mix air in to the cooling cycle on installation or removal of the air conditioner.** 
If air is mixed in, the pressure in the cooling cycle will rise abnormally and may cause explosion and injuries.
- **Be sure to have the electrical wiring work done by qualified electrical installer, and use exclusive circuit.** 
Power source with insufficient capacity and improper work can cause electric shock and fire.
- **Use specified wire for electrical wiring, fasten the wiring to the terminal securely, and hold the cable securely in order not to apply unexpected stress on the terminal.** 
Loose connections or hold could result in abnormal heat generation or fire.
- **Arrange the electrical wires in the control box properly to prevent them from rising. Fit the lid of the services panel properly.** 
Improper fitting may cause abnormal heat and fire.
- **Check for refrigerant gas leakage after installation is completed.** 
If the refrigerant gas leaks into the house and comes in contact with a fan heater, a stove, or an oven, toxic gas is produced.
- **Use the specified pipe, flare nut, and tools for R410A.** 
Using existing parts (R22) could cause the unit failure and serious accident due to explosion of the cooling cycle.
- **Tighten the flare nut according to the specified method by with torque wrench.** 
If the flare nut were tightened with excess torque, it could cause burst and refrigerant leakage after a long period.
- **Do not put the drainage pipe directly into drainage channels where poisonous gases such as sulfide gas can occur.** 
Poisonous gases will flow into the room through drainage pipe and seriously affect the user's health and safety. This can also cause the corrosion of the indoor unit and a resultant unit failure or refrigerant leak.
- **Connect the pipes for refrigeration circuit securely in installation work before compressor is operated.** 
If the compressor is operated when the service valve is open without connecting the pipe, it could cause explosion and injuries due to abnormal high pressure in the system.
- **Stop the compressor before removing the pipe after shutting the service valve on pump down work.** 
If the pipe is removed when the compressor is in operation with the service valve open, air would be mixed in the refrigeration circuit and it could cause explosion and injuries due to abnormal high pressure in the cooling cycle.
- **Only use prescribed optional parts. The installation must be carried out by the qualified installer.** 
If you install the system by yourself, it can cause serious trouble such as water leaks, electric shocks, fire.
- **Do not repair by yourself. And consult with the dealer about repair.** 
Improper repair may cause water leakage, electric shock or fire.
- **Consult the dealer or a specialist about removal of the air conditioner.** 
Improper installation may cause water leakage, electric shock or fire.
- **Turn off the power source during servicing or inspection work.** 
If the power is supplied during servicing or inspection work, it could cause electric shock and injury by the operating fan.
- **Do not run the unit when the panel or protection guard are taken off.** 
Touching the rotating equipment, hot surface, or high voltage section could cause an injury to be caught in the machine, to get burned, or electric shock.
- **Shut off the power before electrical wiring work.** 
It could cause electric shock, unit failure and improper running.

- **cause unit failure and electric shock due to a short circuit.** 
Improper earth could
- **Earth leakage breaker must be installed.** 
If the earth leakage breaker is not installed, it can cause electric shocks.
- **Use the circuit breaker of correct capacity. Circuit breaker should be the one that disconnect all poles under over current.** 
Using the incorrect one could cause the system failure and fire.
- **Do not use any materials other than a fuse of correct capacity where a fuse should be used.** 
Connecting the circuit by wire or copper wire could cause unit failure and fire.
- **Do not install the indoor unit near the location where there is possibility of flammable gas leakages.** 
If the gas leaks and gathers around the unit, it could cause fire.
- **Do not install and use the unit where corrosive gas (such as sulfurous acid gas etc.) or flammable gas (such as thinner, petroleum etc.) may be generated or accumulated, or volatile flammable substances are handled.** 
It could cause the corrosion of heat exchanger, breakage of plastic parts etc. And inflammable gas could cause fire.
- **Secure a space for installation, inspection and maintenance specified in the manual.** 
Insufficient space can result in accident such as personal injury due to falling from the installation place.
- **Do not use the indoor unit at the place where water splashes such as laundry.** 
Indoor unit is not waterproof. It could cause electric shock and fire.
- **Do not use the indoor unit for a special purpose such as food storage, cooling for precision instrument, preservation of animals, plants, and a work of art.** 
It could cause the damage of the items.
- **Do not install nor use the system near equipments which generate electromagnetic wave or high harmonics.** 
Equipments like inverter equipment, private power generator, high-frequency medical equipment, or telecommunication equipment might influence the air conditioner and cause a malfunction and breakdown. Or the air conditioner might influence medical equipments or telecommunication equipments, and obstruct their medical activity or cause jamming.
- **Do not install the remote controller at the direct sunlight.** 
It could cause breakdown or deformation of the remote controller.
- **Do not install the indoor unit at the place listed below.** 
 - Places where flammable gas could leak.
 - Places where carbon fiber, metal powder or any powder is floated.
 - Place where the substances which affect the air conditioner are generated such as sulfide gas, chloride gas, acid, alkali or ammoniac atmospheres.
 - Places exposed to oil mist or steam directly.
 - On vehicles and ships
 - Places where machinery which generates high harmonics is used.
 - Places where cosmetics or special sprays are frequently used.
 - Highly salted area such as beach.
 - Heavy snow area
 - Places where the system is affected by smoke from a chimney.
 - Altitude over 1000m
- **Do not install the indoor unit in the locations listed below (Be sure to install the indoor unit according to the installation manual for each model because each indoor unit has each limitation)** 
 - Locations with any obstacles which can prevent inlet and outlet air of the unit
 - Locations where vibration can be amplified due to insufficient strength of structure.
 - Locations where the infrared receiver is exposed to the direct sunlight or the strong light beam. (in case of the infrared specification unit)
 - Locations where an equipment affected by high harmonics is placed. (TV set or radio receiver is placed within 5m)
 - Locations where drainage cannot run off safely.
 It can affect performance or function and etc...
- **Do not put any valuables which will break down by getting wet under the air conditioner.** 
Condensation could drop when the relative humidity is higher than 80% or drain pipe is clogged, and it damages user's belongings.
- **Do not use the base frame for the outdoor unit which is corroded or damaged after a long period of use.** 
It could cause the unit falling down and injury.
- **Pay attention not to damage the drain pan by weld sputter when brazing work is done near the unit.** 
If sputter entered into the unit during brazing work, it could cause damage (pinhole) of drain pan and leakage of water. To avoid damaging, keep the indoor unit packed or cover the indoor unit.
- **Install the drain pipe to drain the water surely according to the installation manual.** 
Improper connection of the drain pipe may cause dropping water into room and damaging user's belongings.
- **Do not share the drain pipe for indoor unit and GHP (Gas Heat Pump system) outdoor unit.** 
Toxic exhaust gas would flow into room and it might cause serious damage (some poisoning or deficiency of oxygen) to user's health and safety.
- **Be sure to perform air tightness test by pressurizing with nitrogen gas after completed refrigerant piping work.** 
If the density of refrigerant exceeds the limit in the event of refrigerant leakage in the small room, lack of oxygen can occur, which can cause serious accidents.
- **For drain pipe installation, be sure to make descending slope of greater than 1/100, not to make traps, and not to make air-bleeding.** 
Check if the drainage is correctly done during commissioning and ensure the space for inspection and maintenance.
- **Ensure the insulation on the pipes for refrigeration circuit so as not to condense water.** 
Incomplete insulation could cause condensation and it would wet ceiling, floor, and any other valuables.
- **Do not install the outdoor unit where is likely to be a nest for insects and small animals.** 
Insects and small animals could come into the electronic components and cause breakdown and fire. Instruct the user to keep the surroundings clean.
- **Pay extra attention, carrying the unit by hand.** 
Carry the unit with 2 people if it is heavier than 20kg. Do not use the plastic straps but the grabbing place, moving the unit by hand. Use protective gloves in order to avoid injury by the aluminum fin.
- **Make sure to dispose of the packaging material.** 
Leaving the materials may cause injury as metals like nail and woods are used in the package.
- **Do not operate the system without the air filter.** 
It may cause the breakdown of the system due to clogging of the heat exchanger.
- **Do not touch any button with wet hands.** 
It could cause electric shock.
- **Do not touch the refrigerant piping with bare hands when in operation.** 
The pipe during operation would become very hot or cold according to the operating condition, and it could cause a burn or frostbite.
- **Do not clean up the air conditioner with water.** 
It could cause electric shock.
- **Do not turn off the power source immediately after stopping the operation.** 
Be sure to wait for more than 5 minutes. Otherwise it could cause water leakage or breakdown.
- **Do not control the operation with the circuit breaker.** 
It could cause fire or water leakage. In addition, the fan may start operation unexpectedly and it may cause injury.

○ This model is high static ducted type air conditioning unit. Therefore, do not use this model for direct blow type air conditioning unit.

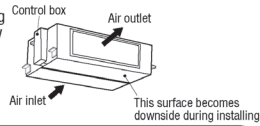

Все каталоги и инструкции здесь: <http://splitoff.ru/tehn-doc.html>

● Confirm the following points:

- Unit type/Power supply specification
- Pipes/Wires/Small parts
- Accessory items

Accessory item

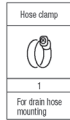

Accessories storage position (during packing)

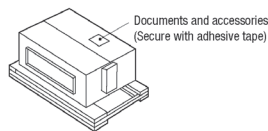

② Selection of installation location for the indoor unit

- Select the suitable areas to install the unit under approval of the user.
 - Areas where the indoor unit can deliver hot and cold wind sufficiently. Suggest to the user to use a circulator if the ceiling height is over 3m to avoid warm air being accumulated on the ceiling.
 - Areas where there is enough space to install and service.
 - Areas where it can be drained properly. Areas where drain pipe descending slope can be taken.
 - Areas where there is no obstruction of airflow on both air return grille and air supply port.
 - Areas where fire alarm will not be accidentally activated by the air conditioner.
 - Areas where the supply air does not short-circuit.
 - Areas where it is not influenced by draft air.
 - Areas not exposed to direct sunlight.
 - Areas where dew point is lower than around 28°C and relative humidity is lower than 80%.
 (This indoor unit is tested under the condition of JIS (Japan Industrial Standard) high humidity condition and confirmed there is no problem. However, there is some risk of condensation drop if the air conditioner is operated under the severer condition than mentioned above.
 If there is a possibility to use it under such a condition, attach additional insulation of 10 to 20mm thick for entire surface of indoor unit, refrigeration pipe and drain pipe.)
 - Areas where TV and radio stays away more than 1m. (It could cause jamming and noise.)
 - Areas where any items which will be damaged by getting wet are not placed such as food, table wares, server, or medical equipment under the unit.
 - Areas where there is no influence by the heat which cookware generates.
 - Areas where not exposed to oil mist, powder and/or steam directly such as above fryer.
 - Areas where lighting device such as fluorescent light or incandescent light doesn't affect the operation.
 (A beam from lighting device sometimes affects the infrared receiver for the wireless remote controller and the air conditioner might not work properly.)
- Check if the place where the air conditioner is installed can hold the weight of the unit. If it is not able to hold, reinforce the structure with boards and beams strong enough to hold it. If the strength is not enough, it could cause injury due to unit falling.

Space for installation and service

● Make installation altitude over 2.5m.

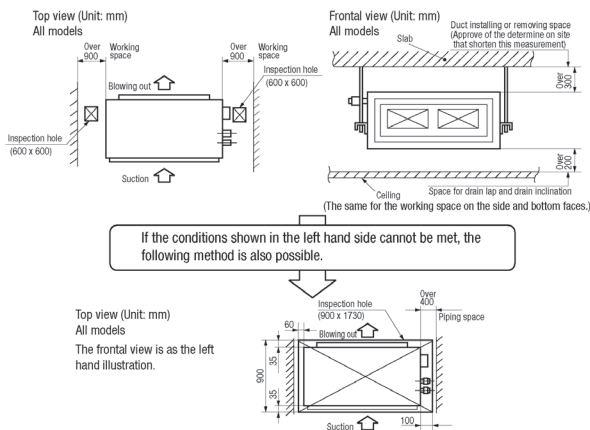

Air Conditions and Airflow Limits

Single	Multi	Rating	Airflow m ³ /min		Temperature of the blow-in air of the indoor unit		Air temperature surrounding the indoor unit
			Lower limit	Upper limit	Cooler	Heater	
200	224	51	38	65	Upper limit 26°C WB When outdoor temperature is 35°C Lower limit 16°C WB When outdoor temperature is 15°C	Upper limit 27°C DB Outdoor temperature is below 20°C WB Lower limit 10°C DB Outdoor temperature is above 10°C WB	Dew point temperature below 26°C
250	280	68	51	87	Refer to the technical document published by our company for more details.		

③ Preparation before installation

- If suspension bolt becomes longer, do reinforcement of earthquake resistant.
- For grid ceiling
 When the suspension bolt length is over 500mm, or the gap between the ceiling and roof is over 700mm, apply earthquake resistant brace to the bolt.
 ceiling plane which
 nt brace to the bolt.
 on site.

Suspension bolts pitch, Pipe position

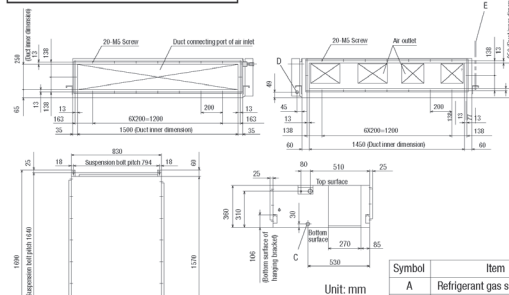

Symbol	Item
A	Refrigerant gas side piping
B	Refrigerant liquid side piping
C	Drain piping connection port
D	Power source inlet port
E	Suspension bolt

④ Installation of indoor unit

Installation

[Hanging]

○ Hang the unit up.

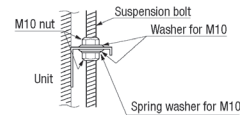

○ If the measurements between the unit and the ceiling hole do not match upon installation, it may be adjusted with the long holed installation tool.



[Method for Fixing the Suspension Bolt]

○ Secure the suspension bolt with one of the methods shown in the following illustration.

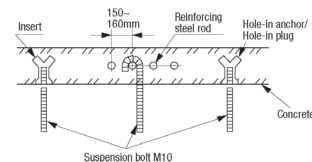

Horizontal Adjustment

○ Use a level vial or adjust the level as shown in the following illustration.

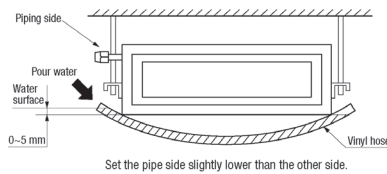

○ If it is not horizontal, the float switch malfunctions or does not function.

(Packing Tools)

The packing tools (4) are not necessary. Packing tools (4) should be removed.

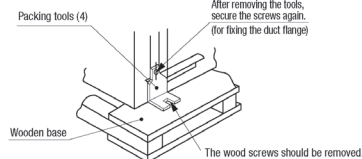

⑤ Duck work

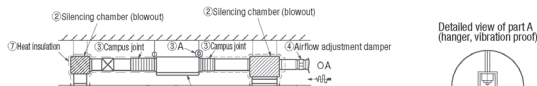

Все каталоги и инструкции здесь: <http://splitoff.ru/tehn-doc.html>

- ① Air filters are not provided with the main frame of the air conditioner. Assemble on to the suction grill which can be cleaned easily.
- ② Fit the silencing chamber according to the noise level tolerance inside the installation room. If it is particularly necessary to keep the noise level low, further silencing devices is required (always install them in offices, and conference rooms).
- ③ In order to keep the vibration from transferring to the ceiling and the slab, use a campus joint for the duct and a vibration proof rubber for the main frame.
- ④ Attach an airflow adjustment damper to the connection point of the OA duct so airflow adjustment may be possible after installation.
- ⑤ For the blowing outlet, select a shape and location where air may circulate, and a structure where airflow may be controlled.
- ⑥ An inspection hole must be made in the ceiling surface. This is necessary for the repair and maintenance of the electrical parts, motor and functional parts, as well as for cleaning the heat exchanger.
- ⑦ Insulation must be performed for the duct to prevent water condensation on the duct. The thickness of the insulating material is 65 mm (JISA 9501).

A bad example of duct work

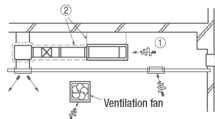

① If the suction duct is not used, and the attic is used as a suction duct, the attic will become extremely humid depending on the performance of the ventilation fan, the strength of wind blowing to the atmospheric gallery and the climate (e.g., rainy days).

- a. Condensation occurs on the outer board of the unit and water may fall on the ceiling. Use the unit according to the air conditions in the above table and airflow limits. In concrete constructions, high humidity can occur in new constructions even when the attic is not used as a suction duct. In this case, insulate the entire unit with glass wool (25 mm) (use a metal net to hold the wool).
 - b. Operation of the unit may exceed its limits (for example, when the temperature of the suction air is 24 °C with the outdoor temperature of 35 °C DB). In such a cases, problems such as an overload of the compressor may occur.
 - c. The volume of the air blowing in may increase due to the performance of the ventilation fan and the wind strength blowing against the atmospheric gallery. The air usage limit may be exceeded, and the water from the heat exchanger will not be able to drain to the drain pan. Instead it will drain outside and cause a water leak (to the ceiling).
- ② If vibration damping is not conducted between the unit and the duct, and between the unit and the slab, vibration will be transmitted to the duct and vibration noise may occur. Also, vibration may be transmitted from the unit to the slab. Vibration damping must be performed.

Simple setting method for duct measurement

The following shows the method when duct is used at one side of 250mm as 1Pa/m by frictional resistance per the unit length of the duct, and in case of 250 type (single unit)/280 type (multi unit), 60Hz rating airflow for an example.

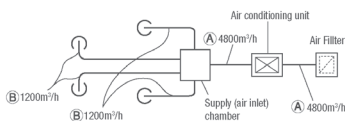

	Airflow	Duct (mm x mm)
A	4800m ³ /h (80m ³ /min)	250 x 950
B	1200m ³ /h (20m ³ /min)	250 x 310

○ Calculation of duct resistance
(Simplified calculate as following table)

Straight piping port	Calculate at 1Pa per 1m length to 1Pa/m
Bending port	Calculate at 3 to 4 m straight pipe per 1 piece of binding pipe
Air outlet port	Calculate at 25Pa
Chamber	Calculate at 50Pa per 1 piece
Air inlet grille (with filter)	Calculate at 40Pa per 1 piece

[Simplified duct dimension selection table]		1Pa/m
Duct type		□ Quadrangle duct
Airflow	Item	Dimensions
m ³ /h (m ³ /min)		(mm×mm)
100		250× 60
200		250× 90
300		250× 120
400		250× 140
450 (7.5)		250× 160
500		250× 170
600 (10)		250× 190
800		250× 230
1,000		250× 270
1,200 (20)	●	250× 310
1,400		250× 350
1,600		250× 390
1,800 (30)	●	250× 430
2,000		250× 470
2,400 (40)	●	250× 560
3,000 (50)	●	250× 650
3,500		250× 740
4,000		250× 830
4,500		250× 920
4,800 (80)	●	250× 950
5,000		250×1000
5,500		250×1090
6,000 (100)	●	250×1180

⑥ Refrigerant pipe

Caution

- Use the new refrigerant pipe.
Using other refrigerant except R410A (R22 etc.) may degrade inside refrigeration oil. And air getting into refrigeration circuit may cause over-pressure and resultant it may result in bursting, etc.
- Change the flare nuts with the attached ones (JIS category 2), and reprocess the flare parts.

Refrigeration pipe installation. Do not use any refrigerant other than R410A. Do not use any refrigerant other than R410A. Do not use any refrigerant other than R410A. Do not use any refrigerant other than R410A.

- Do not use any refrigerant other than R410A.
- Using other refrigerant except R410A (R22 etc.) may degrade inside refrigeration oil. And air getting into refrigeration circuit may cause over-pressure and resultant it may result in bursting, etc.
- Store the copper pipes indoors and seal the both end of them until they are brazed in order to avoid any dust, dirt or water getting into pipe. Otherwise it will cause degradation of refrigeration oil and compressor breakdown, etc.
- Use special tools for R410 refrigerant.
- The indoor unit pipes allow the maintenance panel to be removed. Therefore, regardless of the piping direction, there should be a straight section of 400 mm or more.

Work procedure

1. When brazing work, perform it while cool down around the brazing port with wet towels to prevent the overheating.
2. After check the gas leak test, install the heat insulation (prepare on site) to the brazing port of the indoor unit.
 - Be sure to perform the heat insulation both of gas side piping with liquid side piping.
 - ※ If heat insulation does not install to the pipes, dew condensation may occurs and it may cause the water leakage.
 - The thickness of the heat insulation should be more than 20mm.
3. Refrigerant is charged in the outdoor unit.
As for the additional refrigerant charge for the indoor unit and piping, refer to the installation manual attached to the outdoor unit.

Single unit		Multi unit				
Type 200	Liquid piping	φ 9.52	Type 224	Liquid piping	φ 9.52	Flaring
	Gas piping	φ 25.4		Gas piping	φ 19.05	Flaring
Type 250	Liquid piping	φ 12.7	Type 280	Liquid piping	φ 9.52	Flaring
	Gas piping	φ 25.4		Gas piping	φ 22.22	Flaring

⑦ Drain pipe

Caution

- Install the drain pipe according to the installation manual in order to drain properly. Imperfection in draining may cause flood indoors and wetting the household goods, etc.
- Do not put the drain pipe directly into the ditch where toxic gas such as sulfur, the other harmful and inflammable gas is generated. Toxic gas would flow into the room and it would cause serious damage to user's health and safety (some poisoning or deficiency of oxygen). In addition, it may cause corrosion of heat exchanger and bad smell.
- Connect the pipe securely to avoid water leakage from the joint.
- Insulate the pipe properly to avoid condensation drop.
- Check if the water can flow out properly from both the drain outlet on the indoor unit and the end of the drain pipe after installation.
- Make sure to make descending slope of greater than 1/100 and do not make up-down bend and/or trap in the midway. In addition, do not put air vent on the drain pipe. Check if water is drained out properly from the pipe during commissioning. Also, keep sufficient space for inspection and maintenance.

Work procedure

1. Insert the supplied drain hose (the end made of soft PVC) to the step of the drain socket on the indoor unit and fix it securely with the clamp.
 - Do not apply adhesives on this end.

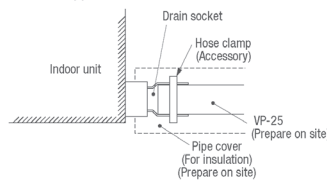

2. Prepare a joint for connecting VP-25 pipe, adhere and connect the joint to the drain hose (the end made of rigid PVC), and adhere and connect VP-25 pipe (prepare on site).
 - ※ As for drain pipe, apply VP-25 made of rigid PVC which is on the market.
 - Make sure that the adhesive will not get into the supplied drain hose. It may cause the flexible part broken after the adhesive is dried up and gets rigid.
 - The flexible drain hose is intended to absorb a small difference at installation of the unit or drain pipes. Intentional bending, expanding may cause the flexible hose broken and water leakage.

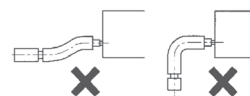

⑦ Drain pipe (continued)

3. Make sure to make descending slope of greater than 1/100 and do not make up-down bend and/or trap in the midway.
 - Pay attention not to give stress on the pipe on the indoor unit side, and support and fix the pipe at the outdoor side.

Все каталоги и инструкции здесь: <http://splitoff.ru/tehn-doc.html>

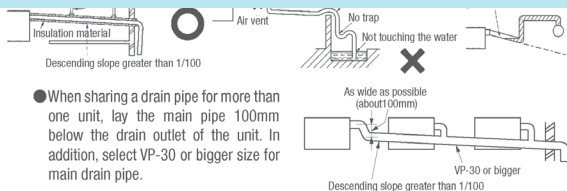

- When sharing a drain pipe for more than one unit, lay the main pipe 100mm below the drain outlet of the unit. In addition, select VP-30 or bigger size for main drain pipe.

4. Insulate the drain pipe.
 - Be sure to insulate the drain socket and rigid PVC pipe installed indoors otherwise it may cause dew condensation and water leakage.
 - ※ After drainage test implementation, cover the drain socket part with pipe cover (small size), then use the pipe cover (big size) to cover the pipe cover (small size), clamps and part of the drain hose, and fix and wrap it with tapes to wrap and make joint part gapless.

Caution

When the duct is connected and the blowing device is operated, the pressure inside the unit becomes negative to the atmospheric pressure.

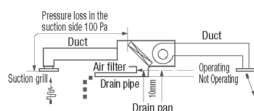

Example: As shown in the above illustration, if the pressure loss of the suction grill, air filter, and the suction side of the duct is 100 Pa, the drain water level during operation is 10mm higher than when it is not operating.

Fixing Traps

The pressure loss varies depending on the clogging in the air filter. Therefore, make one trap (during the piping work) to prevent water from remaining in the drain pan. It is necessary to make a trap with a structure that allows cleaning. Use the T joint as demonstrated in the left illustration. Also, set the trap height as shown in the left illustration. Arrange the trap near to the unit.

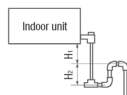

- Make one trap along the drain pipe as the left illustration.

H1 = 100 mm or the static pressure of the blowing device
H2 = 1/2 H1 or 50 ~ 100 mm

Drain test

Upon completion of drain piping, check by running water through it.

- Remove the side panel and gradually pour 1000 cc of water into the drain pan. Ensure that the water drains smoothly.

Also, ensure that there are no water leaks from the connections and joints.

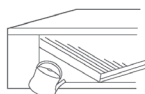

⑧ Wiring-out position and wiring connection

- Electrical installation work must be performed according to the installation manual by an electrical installation service provider qualified by a power provider of the country, and be executed according to the technical standards and other regulations applicable to electrical installation in the country.

the cord securely in

- Do not put both power source line and signal line on the same route. It may cause miscommunication and malfunction.
- Be sure to do D type earth work.
- For the details of electrical wiring work, see attached instruction manual for electrical wiring work.

1. Remove a lid of the control box (2 screws) and a hook which is located on top of it.
2. Hold each wiring inside the unit and fasten them to terminal block securely.
3. Fix the wiring with clamps.
4. Install the removed parts back to original place.

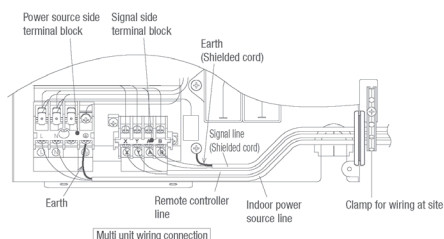
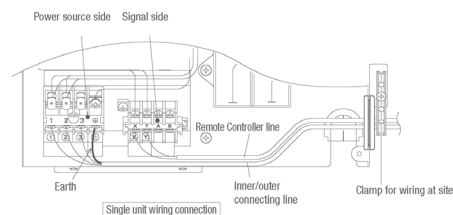

⑨ Check list after installation

- Check the following items after all installation work completed.



Check if	Expected trouble	Check
The indoor and outdoor units are fixed securely?	Falling, vibration, noise	
Inspection for leakage is done?	Insufficient capacity	
Insulation work is properly done?	Water leakage	
Water is drained properly?	Water leakage	
Supply voltage is same as mentioned in the model name plate?	PCB burnt out, not working at all	
There is mis-wiring or mis-connection of piping?	PCB burnt out, not working at all	
Earth wiring is connected properly?	Electric shock	
Cable size comply with specified size?	PCB burnt out, not working at all	
Any obstacle blocks airflow on air inlet and outlet?	Insufficient capacity	

(2) Installation manual for wired remote controller

PJA012D729A 

Read together with indoor unit's installation manual.



Все каталоги и инструкции здесь: <http://splitoff.ru/tehn-doc.html>

- Fasten the wiring to the terminal securely, and hold the cable securely so as not to apply unexpected stress on the terminal.
Loose connection or hold will cause abnormal heat generation or fire. 
- Make sure the power supply is turned off when electric wiring work.
Otherwise, electric shock, malfunction and improper running may occur. 

CAUTION

- DO NOT install the remote controller at the following places in order to avoid malfunction.

(1) Places exposed to direct sunlight	(4) Hot surface or cold surface enough to generate condensation
(2) Places near heat devices	(5) Places exposed to oil mist or steam directly
(3) High humidity places	(6) Uneven surface

- DO NOT leave the remote controller without the upper case.
In case the upper case needs to be detached, protect the remote controller with a packaging box or bag in order to keep it away from water and dust. 

Accessories	Remote controller, wood screw (ø3.5×16) 2 pieces
Prepare on site	Remote controller cord (2 cores) the insulated thickness in 1mm or more. [In case of embedding cord] Electrical box, M4 screw (2 pieces) [In case of exposing cord] Cord clamp (if needed)

Installation procedure

- ① Open the cover of remote controller, and remove the screw under the buttons without fail.
- ② Remove the upper case of remote controller.
Insert a flat-blade screwdriver into the dented part of the upper part of the remote controller, and wrench slightly.

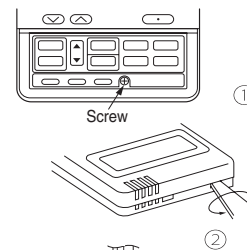

[In case of embedding cord]

- ③ Embed the electrical box and remote controller cord beforehand.

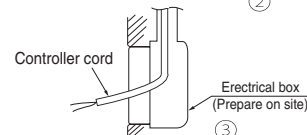

- ④ Prepare two M4 screws (recommended length is 12-16mm) on site, and install the lower case to electrical box. Choose either of the following two positions in fixing it with screws.

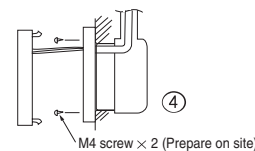
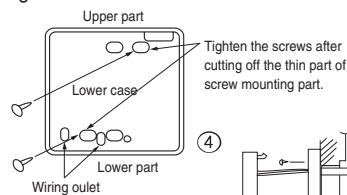
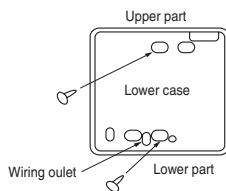

- ⑤ Connect the remote controller cord to the terminal block.
Connect the terminal of remote controller (X,Y) with the terminal of indoor unit (X,Y). (X and Y are no polarity)

- ⑥ Install the upper case as before so as not to catch up the remote controller cord, and tighten with the screws.

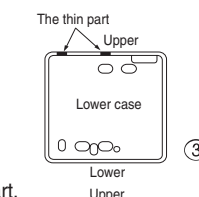

[In case of exposing cord]

- ③ You can pull out the remote controller cord from left upper part or center upper part.
Cut off the upper thin part of remote controller lower case with a nipper or knife, and grind burrs with a file etc.

- ④ Install the lower case to the flat wall with attached two wooden screws.

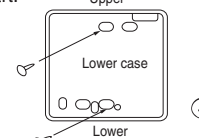

- ⑤ Connect the remote controller cord to the terminal block.
Connect the terminal of remote controller (X,Y) with the terminal of indoor unit (X,Y).

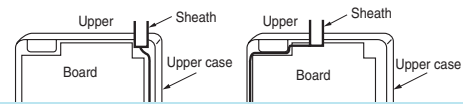

Все каталоги и инструкции здесь: <http://splitoff.ru/tehn-doc.html>

depending on the pulling out direction.

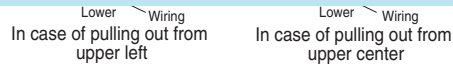

The wiring inside the remote controller case should be within 0.3mm² (recommended) to 0.5mm².
The sheath should be peeled off inside the remote controller case.
The peeling-off length of each wire is as below.

Pulling out from upper left	Pulling out from upper center
X wiring : 215mm	X wiring : 170mm
Y wiring : 195mm	Y wiring : 190mm

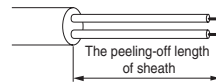

- ⑥ Install the upper case as before so as not to catch up the remote controller cord, and tighten with the screws.
- ⑦ In case of exposing cord, fix the cord on the wall with cord clamp so as not to slack.

Installation and wiring of remote controller

- ① Wiring of remote controller should use 0.3mm² × 2 core wires or cables. (on-site configuration)
- ② Maximum prolongation of remote controller wiring is 600 m.
If the prolongation is over 100m, change to the size below.
But, wiring in the remote controller case should be under 0.5mm². Change the wire size outside of the case according to wire connecting. Waterproof treatment is necessary at the wire connecting section. Be careful about contact failure.
100 - 200m.....0.5mm² × 2 cores
Under 300m.....0.75mm² × 2 cores
Under 400m.....1.25mm² × 2 cores
Under 600m.....2.0mm² × 2 cores

Master/ slave setting when more than one remote controllers are used

A maximum of two remote controllers can be connected to one indoor unit (or one group of indoor units.)

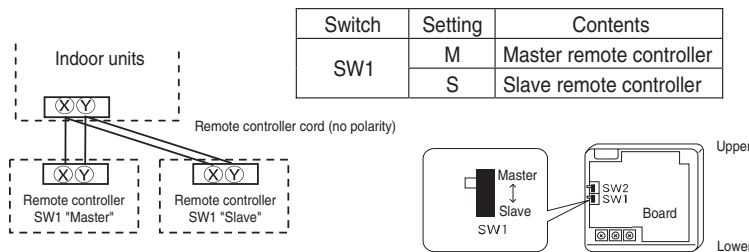

Set SW1 to "Slave" for the slave remote controller. It was factory set to "Master" for shipment.
Note: The setting "Remote controller thermistor enabled" is only selectable with the master remote controller in the position where you want to check room temperature.
The air conditioner operation follows the last operation of the remote controller regardless of the master/ slave setting of it.

The indication when power source is supplied

When power source is turned on, the following is displayed on the remote controller until the communication between the remote controller and indoor unit settled.

Master remote controller : " WAIT M"
Slave remote controller : " WAIT S"

At the same time, a mark or a number will be displayed for two seconds first.
This is the software's administration number of the remote controller, not an error cod.

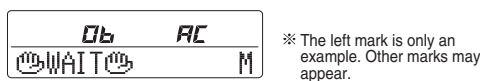

When remote controller cannot communicate with the indoor unit for half an hour, the below indication will appear.
Check wiring of the indoor unit and the outdoor unit etc.

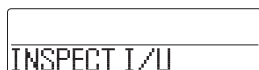

The range of temperature setting

When shipped, the range of set temperature differs depending on the operation mode as below.

Heating : 16~30°C (55~86°F)

Except heating (cooling, fan, dry, automatic) : 18~26°C (62~79°F)

Все каталоги и инструкции здесь: <http://splitoff.ru/tehn-doc.html>

Upper limit setting: valid during heating operation. Possible to set in the range of 20 to 30°C (68 to 86°F).

Lower limit setting: valid except heating (automatic, cooling, fan, dry) Possible to set in the range of 18 to 26°C (62 to 79°F).

When you set upper and lower limit by this function, control as below.

1. When ⑫ TEMP RANGE SET, remote controller function of function setting mode is "INDN CHANGE" (factory setting),
 [If upper limit value is set]
 During heating, you cannot set the value exceeding the upper limit.
 [If lower limit value is set]
 During operation mode except heating, you cannot set the value below the lower limit.
2. When ⑫ TEMP RANGE SET, remote controller function of function setting mode is "NO INDN CHANGE"
 [If upper limit value is set]
 During heating, even if the value exceeding the upper limit is set, upper limit value will be sent to the indoor unit.
 But, the indication is the same as the temperature set.
 [If lower limit value is set]
 During except heating, even if the value lower than the lower limit is set, lower limit value will be sent to the indoor unit.
 But, the indication is the same as the temperature set.

● **How to set upper and lower limit value**

1. Stop the air-conditioner, and press (SET) and (MODE) button at the same time for over three seconds .
 The indication changes to "FUNCTION SET ▼".
2. Press button once, and change to the "TEMP RANGE ▲" indication.
3. Press (SET) button, and enter the temperature range setting mode.
4. Select "UPPER LIMIT ▼" or "LOWER LIMIT ▲" by using button.
5. Press (SET) button to fix.
6. When "UPPER LIMIT ▼" is selected (valid during heating)
 - ① Indication: " √ ∆ SET UP" → "UPPER 30°C √"
 - ② Select the upper limit value with temperature setting button . Indication example: "UPPER 26°C √ ∆" (blinking)
 - ③ Press (SET) button to fix. Indication example: "UPPER 26°C" (Displayed for two seconds)
 After the fixed upper limit value displayed for two seconds, the indication will return to "UPPER LIMIT ▼".
7. When "LOWER LIMIT ▲" is selected (valid during cooling, dry, fan, automatic)
 - ① Indication: " √ ∆ SET UP" → "LOWER 18°C ∆"
 - ② Select the lower limit value with temperature setting button . Indication example: "LOWER 24°C √ ∆" (blinking)
 - ③ Press (SET) button to fix. Indication for example: "LOWER 24°C" (Displayed for two seconds)
 After the fixed lower limit value displayed for two seconds, the indication will return to "LOWER LIMIT ▼".
8. Press button to finish.

• It is possible to finish by pressing button on the way, but unfinished change of setting is unavailable.

• During setting, if you press (RESET) button, you return to the previous screen.

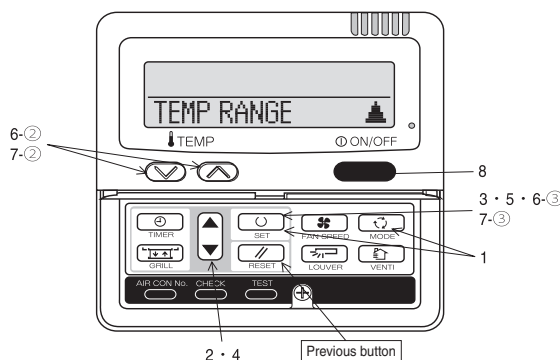

The functional setting

Refer to page 204

How to set function

1. Stop air-conditioner and press (SET) (MODE) buttons at the same time for over three seconds, and the "FUNCTION SET" screen is displayed.

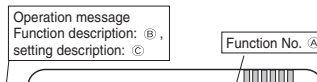

Все каталоги и инструкции здесь: <http://splitoff.ru/tehn-doc.html>

2. Press (SET) button.
3. Make sure which do you want to set, "FUNCTION ▼" (remote controller function) or "I/U FUNCTION ▲" (indoor unit function).
4. Press or button.
Select "FUNCTION ▼" (remote controller function) or "I/U FUNCTION ▲" (indoor unit function).

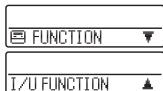

5. Press (SET) button.

6. [On the occasion of remote controller function selection]

① "DATA LOADING" (Indication with blinking)
↓
Display is changed to "01 GRILLE ↑↓SET".

② Press or button.
"No. and function" are indicated by turns on the remote controller function table, then you can select from them.
(For example)

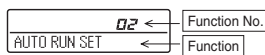

③ Press (SET) button.
The current setting of selected function is indicated.
(for example) "AUTO RUN ON" ← If "02 AUTO RUN SET" is selected

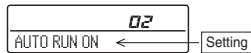

④ Press or button.
Select the setting.

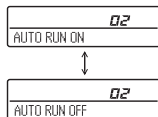

⑤ Press (SET) button.
"SET COMPLETE" will be indicated, and the setting will be completed.
Then after "No. and function" indication returns, Set as the same procedure if you want to set continuously, and if to finish, go to 7.



7. Press button.
Setting is finished.

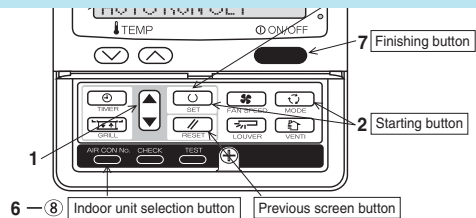

[On the occasion of indoor unit function selection]

① "DATA LOADING" (Blinking for 2 to 23 seconds to read the data)
↓
Indication is changed to "02 FAN SPEED SET".
Go to ②.

[Note]

(1) If plural indoor units are connected to a remote controller, the indication is "I/U 000" (blinking) ← The lowest number of the indoor unit connected is indicated.

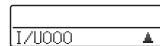

(2) Press or button.
Select the number of the indoor unit you are to set
If you select "ALL UNIT ▼", you can set the same setting with all unites.

(3) Press (SET) button.

② Press or button.
"No. and function" are indicated by turns on the indoor unit function table, then you can select from them.
(For example)

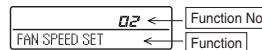

③ Press (SET) button.
The current setting of selected function is indicated.
(For example) "STANDARD" ← If "02 FAN SPEED SET" is selected.

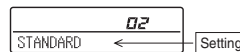

④ Press or button.
Select the setting.

⑤ Press (SET) button.
"SET COMPLETE" will be indicated, and the setting will be completed.
Then after "No. and function" indication returns, set as the same procedure if you want to set continuously, and if to finish, go to 7.



※ When plural indoor units are connected to a remote controller, press the button, which allows you to go back to the indoor unit selection screen. (example "I/U 000 ▲")

- It is possible to finish by pressing button on the way, but unfinished change of setting is unavailable.
- During setting, if you press (RESET) button, you return to the previous screen.
- Setting is memorized in the controller and it is saved independently of power failure.

[How to check the current setting]

When you select from "No. and function" and press set button by the previous operation, the "Setting" displayed first is the current setting.
(But, if you select "ALL UNIT ▼", the setting of the lowest number indoor unit is displayed.)

(3) Installation of outdoor unit
(a) Models SRC40 ~ 60ZIX-S



RWC012A029B 

Model 40-50-60
R410A REFRIGERANT USED



- This installation manual deals with outdoor units and general installation specifications only. For indoor units, refer to the respective installation manuals supplied with the units.
- When install the unit, be sure to check whether the selection of installation place, power supply specifications, usage limitation (piping length, height differences between indoor and outdoor units, power supply voltage and etc.) and installation spaces.

SAFETY PRECAUTIONS

- We recommend you to read this "SAFETY PRECAUTIONS" carefully before the installation work in order to gain full advantage of the functions of the unit and to avoid malfunction due to mishandling.
- The precautions described below are divided into **WARNING** and **CAUTION**. The matters with possibilities leading to serious consequences such as death or serious personal injury due to erroneous handling are listed in the **WARNING** and the matters with possibilities leading to personal injury or damage of the unit due to erroneous handling including probability leading to serious consequences in some cases are listed in **CAUTION**. These are very important precautions for safety. Be sure to observe all of them without fail.
- Be sure to confirm no anomaly on the equipment by commissioning after completed installation and explain the operating methods as well as the maintenance methods of this equipment to the user according to the owner's manual.
- Keep the installation manual together with owner's manual at a place where any user can read at any time. Moreover if necessary, ask to hand them to a new user.
- For installing qualified personnel, take precautions in respect to themselves by using suitable protective clothing, gloves, etc., and then perform the installation works.
- Please pay attention not to fall down the tools, etc. when installing the unit at the high position.
- If unusual noise can be heard during operation, consult the dealer.
- Symbols which appear frequently in the text have the following meaning:

	Observe instructions with great care		Strictly prohibited		Provide proper earthing
---	--------------------------------------	---	---------------------	---	-------------------------

WARNING

<p></p> <ul style="list-style-type: none"> • Installation must be carried out by the qualified installer. If you install the system by yourself, it may cause serious trouble such as water leaks, electric shocks, fire and personal injury, as a result of a system malfunction. • Install the system in full accordance with the instruction manual. Incorrect installation may cause bursts, personal injury, water leaks, electric shocks and fire. • Be sure to use only for household and residence. If this appliance is installed in inferior environment such as machine shop and etc., it can cause malfunction. • Use the original accessories and the specified components for installation. If parts other than those prescribed by us are used, it may cause water leaks, electric shocks, fire and personal injury. • Install the unit in a location with good support. Unsuitable installation locations can cause the unit to fall and cause material damage and personal injury. • Ensure the unit is stable when installed, so that it can withstand earthquakes and strong winds. Unsuitable installation locations can cause the unit to fall and cause material damage and personal injury. • Ventilate the working area well in the event of refrigerant leakage during installation. If the refrigerant comes into contact with naked flames, poisonous gas is produced. • Use the prescribed pipes, flare nuts and tools for R410A. Using existing parts (for R22 or R407C) can cause the unit failure and serious accidents due to burst of the refrigerant circuit. 	<ul style="list-style-type: none"> • Tighten the flare nut by torque wrench with specified method. If the flare nut were tightened with excess torque, this may cause burst and refrigerant leakage after a long period. • Do not open the operation valves for liquid line and gas line until completed refrigerant piping work, air tightness test and evacuation. If the compressor is operated in state of opening operation valves before completed connection of refrigerant piping work, air can be sucked into refrigerant circuit, which can cause burst or personal injury due to anomalously high pressure in the refrigerant. • The electrical installation must be carried out by the qualified electrician in accordance with "the norm for electrical work" and "national wiring regulation", and the system must be connected to the dedicated circuit. Power supply with insufficient capacity and incorrect function done by improper work can cause electric shocks and fire. • Be sure to shut off the power before starting electrical work. Failure to shut off the power can cause electric shocks, unit failure or incorrect function of equipment. • Be sure to use the cables conformed to safety standard and cable ampacity for power distribution work. Unconformable cables can cause electric leak, anomalous heat production or fire. • This appliance must be connected to main power supply by means of a circuit breaker or switch (fuse:16A) with a contact separation of at least 3mm. 	<ul style="list-style-type: none"> • Use the prescribed cables for electrical connection, tighten the cables securely in terminal block and relieve the cables correctly to prevent overloading the terminal blocks. Loose connections or cable mountings can cause anomalous heat production or fire. • Arrange the wiring in the control box so that it cannot be pushed up further into the box. Install the service panel correctly. Incorrect installation may result in overheating and fire. • Be sure to fix up the service panels. Incorrect fixing can cause electric shocks or fire due to intrusion of dust or water. • Be sure to switch off the power supply in the event of installation, inspection or servicing. If the power supply is not shut off, there is a risk of electric shocks, unit failure or personal injury due to the unexpected start of fan. • Stop the compressor before disconnecting refrigerant pipes in case of pump down operation. If disconnecting refrigerant pipes in state of opening operation valves before compressor stopping, air can be sucked, which can cause burst or personal injury due to anomalously high pressure in the refrigerant circuit. • Only use prescribed optional parts. The installation must be carried out by the qualified installer. If you install the system by yourself, it can cause serious trouble such as water leaks, electric shocks, fire.
<p></p> <ul style="list-style-type: none"> • Ensure that no air enters in the refrigerant circuit when the unit is installed and removed. If air enters in the refrigerant circuit, the pressure in the refrigerant circuit becomes too high, which can cause burst and personal injury. • Do not processing, splice the power cord, or share a socket with other power plugs. This may cause fire or electric shock due to defecting contact, defecting insulation and over-current etc. 	<ul style="list-style-type: none"> • Do not bundling, winding or processing for the power cord. Or, do not deforming the power plug due to tread it. This may cause fire or heating. • Do not run the unit with removed panels or protections. Touching rotating equipments, hot surfaces or high voltage parts can cause personal injury due to entrapment, burn or electric shocks. 	<ul style="list-style-type: none"> • Do not perform any change of protective device itself or its setup condition. The forced operation by short-circuiting protective device of pressure switch and temperature controller or the use of non specified component can cause fire or burst.

⚠ CAUTION

- !** **Use the circuit breaker with sufficient breaking capacity.**
If the breaker does not have sufficient breaking capacity, it can cause the unit malfunction and fire.

• Earth leakage breaker must be installed.
If the earth leakage breaker is not installed, it can cause electric shocks.

• Install isolator or disconnect switch on the power supply wiring in accordance with the local codes and regulations.

• After maintenance, all wiring, wiring ties and the like, should be returned to their original state and wiring route, and the necessary clearance from all metal parts should be secured.

• Secure a space for installation, inspection and maintenance specified in the manual.
Insufficient space can result in accident such as personal injury due to falling from the installation place.

• Take care when carrying the unit by hand.
If the unit weights more than 20kg, it must be carried by two or more persons. Do not carry by the plastic straps, always use the carry handle when carrying the unit by hand. Use gloves to minimize the risk of cuts by the aluminum fins.

• Dispose of any packing materials correctly.
Any remaining packing materials can cause personal injury as it contains nails and wood. And to avoid danger of suffocation, be sure to keep the plastic wrapper away from children and to dispose after tear it up.

• Be sure to insulate the refrigerant pipes so as not to condense the ambient air moisture on them.
Insufficient insulation can cause condensation, which can lead to moisture damage on the ceiling, floor, furniture and any other valuables.

• When perform the air conditioner operation (cooling or drying operation) in which ventilator is installed in the room. In this case, using the air conditioner in parallel with the ventilator, there is the possibility that drain water may backflow in accordance with the room lapse into the negative pressure status. Therefore, set up the opening port such as incorporate the air into the room that may appropriate to ventilation (For example; Open the door a little). In addition, just as above, set up the opening port if the room lapse into negative pressure status due to register of the wind for the high rise apartment etc.
- ⊘ Do not install the unit in the locations listed below.**

 - Locations where carbon fiber, metal powder or any powder is floating.
 - Locations where any substances that can affect the unit such as sulphide gas, chloride gas, acid and alkaline can occur.
 - Vehicles and ships.
 - Locations where cosmetic or special sprays are often used.
 - Locations with direct exposure of oil mist and steam such as kitchen and machine plant.
 - Locations where any machines which generate high frequency harmonics are used.
 - Locations with salty atmospheres such as coastlines.
 - Locations with heavy snow (If installed, be sure to provide base flame and snow hood mentioned in the manual).
 - Locations where the unit is exposed to chimney smoke.
 - Locations at high altitude (more than 1000m high).
 - Locations with ammonic atmospheres.
 - Locations where heat radiation from other heat source can affect the unit.
 - Locations without good air circulation.
 - Locations with any obstacles which can prevent inlet and outlet air of the unit.
 - Locations where short circuit of air can occur (in case of multiple units installation).
 - Locations where strong air blows against the air outlet of outdoor unit.

It can cause remarkable decrease in performance, corrosion and damage of components, malfunction and fire.

• Do not install the outdoor unit in the locations listed below.

 - Locations where discharged hot air or operating sound of the outdoor unit can bother neighborhood.
 - Locations where outlet air of the outdoor unit blows directly to plants.
 - Locations where vibration can be amplified and transmitted due to insufficient strength of structure.
 - Locations where vibration and operation sound generated by the outdoor unit can affect seriously (on the wall or at the place near bed room).
 - Locations where an equipment affected by high harmonics is placed (TV set or radio receiver is placed within 5m).
 - Locations where drainage cannot run off safely. It can affect surrounding environment and cause a claim.

• Do not install the unit near the location where leakage of combustible gases can occur.
If leaked gases accumulate around the unit, it can cause fire.

• Do not install the unit where corrosive gas (such as sulfurous acid gas etc.) or combustible gas (such as thinner and petroleum gases) can accumulate or collect, or where volatile combustible substances are handled.
Corrosive gas can cause corrosion of heat exchanger, breakage of plastic parts and etc. And combustible gas can cause fire.

• Do not install nor use the system close to the equipment that generates electromagnetic fields or high frequency harmonics.
Equipment such as inverters, standby generators, medical high frequency equipments and telecommunication equipments can affect

the system, and cause malfunctions and breakdowns. The system can also affect medical equipment and telecommunication equipment and obstruct its function or cause jamming.

• Do not install the outdoor unit in a location where insects and small animals can inhabit.
Insects and small animals can enter the electric parts and cause damage or fire. Instruct the user to keep the surroundings clean.

• Do not use the base flame for outdoor unit which is corroded or damaged due to long periods of operation.
Using an old and damage base flame can cause the unit falling down and cause personal injury.

• Do not use any materials other than a fuse with the correct rating in the location where fuses are to be used.
Connecting the circuit with copper wire or other metal thread can cause unit failure and fire.

• Do not touch any buttons with wet hands.
It can cause electric shocks.

• Do not touch any refrigerant pipes with your hands when the system is in operation.
During operation the refrigerant pipes become extremely hot or extremely cold depending the operating condition, and it can cause burn injury or frost injury.

• Do not touch the suction or aluminum fin on the outdoor unit.
This may cause injury.

• Do not put anything on the outdoor unit and operating unit.
This may cause damage the objects or injury due to falling to the object.

Check before installation work

- Model name and power source
- Refrigerant piping length
- Piping, wiring and miscellaneous small parts
- Indoor unit installation manual

Accessories for outdoor unit	Q'ty
① Grommet (Heat pump type only)	4
② Drain elbow (Heat pump type only)	1

Option parts	Q'ty
Ⓐ Sealing plate	1
Ⓑ Sleeve	1
Ⓒ Inclination plate	1
Ⓓ Putty	1
Ⓔ Drain hose (extension hose)	1
Ⓣ Piping cover (for insulation of connection piping)	1

Necessary tools for the installation work	Q'ty
9 Wrench key (Hexagon) [4m/m]	1
10 Vacuum pump	1
11 Vacuum pump adapter (Anti-reverse flow type) (Designed specifically for R410A)	1
12 Gauge manifold (Designed specifically for R410A)	1
13 Charge hose (Designed specifically for R410A)	1
14 Flaring tool set (Designed specifically for R410A)	1
15 Gas leak detector (Designed specifically for R410A)	1
16 Gauge for projection adjustment (Used when flare is made by using conventional flare)	1

Notabilia as a unit designed for R410A

- Do not use any refrigerant other than R410A. R410A will rise to pressure about 1.6 times higher than that of a conventional refrigerant. A cylinder containing R410A has a pink indication mark on the top.
- A unit designed for R410A has adopted a different size indoor unit operation valve charge port and a different size check joint provided in the unit to prevent the charging of a wrong refrigerant by mistake. The processed dimension of the flared part of a refrigerant pipe and a flare nut's parallel size measurement have also been altered to raise strength against pressure. Accordingly, you are required to arrange dedicated R410A tools listed in the table on the right before installing or servicing this unit.
- Do not use a charge cylinder. The use of a charge cylinder will cause the refrigerant composition to change, which results in performance degradation.
- In charging refrigerant, always take it out from a cylinder in the liquid phase.
- All indoor units must be models designed exclusively for R410A. Check connectable indoor unit models in a catalog, etc. (A wrong indoor unit, if connected into the system, will impair proper system operation)

1. HAULAGE AND INSTALLATION (Take particular care in carrying in or moving the unit, and always perform such an operation with two or more persons.)

CAUTION When a unit is hoisted with slings for haulage, take into consideration the offset of its gravity center position. If not properly balanced, the unit can be thrown off-balance and fall.

1) Delivery

- Deliver the unit as close as possible to the installation site before removing it from the packaging.
- When you have to unpack the unit for a compelling reason before you haul it to the installation point, hoist the unit with nylon slings or ropes and protection pads so that you may not damage the unit.

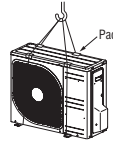

2) Portage

- The right hand side of the unit as viewed from the front (diffuser side) is heavier. A person carrying the right hand side must take heed of this fact. A person carrying the left hand side must hold with his right hand the handle provided on the front panel of the unit and with his left hand the corner column section.

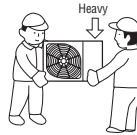

3) Selection of installation location for the outdoor unit

Be sure to select a suitable installation place in consideration of following conditions.

- A place where it is horizontal, stable and can endure the unit weight and will not allow vibration transmittance of the unit.
- A place where it can be free from possibility of bothering neighbors due to noise or exhaust air from the unit.
- A place where the unit is not exposed to oil splashes.
- A place where it can be free from danger of flammable gas leakage.
- A place where drain water can be disposed without any trouble.
- A place where the unit will not be affected by heat radiation from other heat source.
- A place where snow will not accumulate.
- A place where the unit can be kept away 5m or more from TV set and/or radio receiver in order to avoid any radio or TV interference.
- A place where good air circulation can be secured, and enough service space can be secured for maintenance and service of the unit safely.
- A place where the unit will not be affected by electromagnetic waves and/or high-harmonic waves generated by other equipment.
- A place where chemical substances like sulfuric gas, chloric gas, acid and alkali (including ammonia), which can harm the unit, will not be generated and not remain.
- If a operation is conducted when the outdoor air temperature is -5 lower, the outdoor unit should be installed at a place where it is not influenced by natural wind.
- A place where strong wind will not blow against the outlet air blow of the unit.

4) Caution about selection of installation location

- (1) If the unit is installed in the area where the snow will accumulate, following measures are required.

The bottom plate of unit and intake, outlet may be blocked by snow.

- 1 Install the unit on the base so that the bottom is higher than snow cover surface.

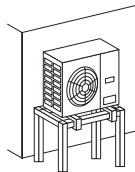

- 2 Provide a snow hood to the outdoor unit on site. Regarding outline of a snow hood, refer to our technical manual.

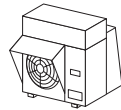

- 3 Install the unit under eaves or provide the roof on site.

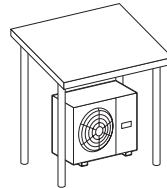

Since drain water generated by defrost control may freeze, following measures are required.

- Don't execute drain piping work by using a drain elbow and drain grommets (optional parts). [Refer to Drain piping work.]
- Recommend setting Defrost Control (SW3-1) and Snow Guard Fan Control (SW3-2). [Refer to Setting SW3-1, SW3-2.]

- (2) If the unit can be affected by strong wind, following measures are required. Strong wind can cause damage of fan (fan motor), or can cause performance degradation, or can trigger anomalous stop of the unit due to rising of high pressure.

1. Install the outlet air blow side of the unit to face a wall of building, or provide a fence or a windbreak screen.

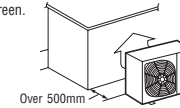

2. Install the outlet air blow side of the unit in a position perpendicular to the direction of wind.

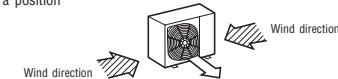

5) Installation space

- Walls surrounding the unit in the four sides are not acceptable.
- There must be a 1-meter or larger space in the above.
- When more than one unit are installed side by side, provide a 250mm or wider interval between them as a service space. In order to facilitate servicing of controllers, please provide a sufficient space between units so that their top plates can be removed easily.
- Where a danger of short-circuiting exists, install guide louvers.
- When more than one unit are installed, provide sufficient intake space consciously so that short-circuiting may not occur.
- Where piling snow can bury the outdoor unit, provide proper snow guards.

Size	Example installation	Model 40, 50, 60 (mm)			
		I	II	III	IV
L1	Open	280	280	180	
L2	100	75	Open	Open	
L3	100	80	80	80	
L4	250	Open	250	Open	

The height of a wall is 1200mm or less.

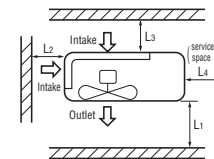

6) Installation

- ① Anchor bolt fixed position

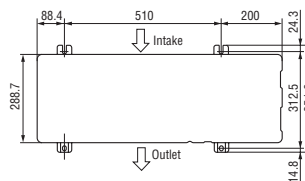

- ② Notabilia for installation

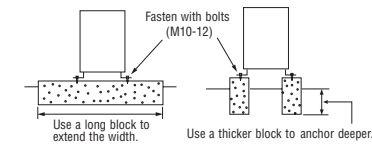

- In installing the unit, fix the unit's legs with bolts specified on the left.
- The protrusion of an anchor bolt on the front side must be kept within 15 mm.
- Securely install the unit so that it does not fall over during earthquakes or strong winds, etc.
- Refer to the above illustrations for information regarding concrete foundations.
- Install the unit in a level area. (With a gradient of 5 mm or less.)
Improper installation can result in a compressor failure, broken piping within the unit and abnormal noise generation.

2. REFRIGERANT PIPING WORK

1) Restrictions on unit installation and use

- Check the following points in light of the indoor unit specifications and the installation site.
- Observe the following restrictions on unit installation and use. Improper installation can result in a compressor failure or performance degradation.

Restrictions		Dimensional restrictions	Marks appearing in the drawing on the right
Main pipe length		30m or less	L
Elevation difference between indoor and outdoor units	When the outdoor unit is positioned higher,	20m or less	H
	When the outdoor unit is positioned lower,	20m or less	H

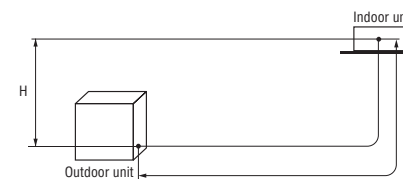

CAUTION ● The use restrictions appearing in the table above are applicable to the standard pipe size combinations shown in the table below. Where an existing pipe system is utilized, different one-way pipe length restrictions should apply depending on its pipe size. For more information, please see "5. UTILIZATION OF EXISTING PIPING."

2) Determination of pipe size

- Determine refrigerant pipe size pursuant to the following guidelines based on the indoor unit specifications.

	Model 40, 50, 60	
	Gas pipe	Liquid pipe
Outdoor unit connected	φ 12.7 Flare	φ 6.35 Flare
Refrigerant piping (branch pipeL)	φ 12.7	φ 6.35
Indoor unit connected	φ 12.7	φ 6.35

When pipe is brazing.

About brazing

Brazing must be performed under a nitrogen gas flow.

Without nitrogen gas, a large quantity of foreign matters (oxidized film) are created, causing a critical failure from capillary tube or expansion valve clogging.

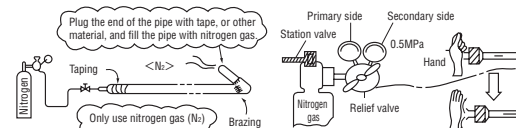

Pipe diameter [mm]	6.35	12.7
Minimum pipe wall thickness [mm]	0.8	0.8
Pipe material*	O-type pipe	O-type pipe

*Phosphorus deoxidized seamless copper pipe ICS 23.040.15, ICS 77.150.30

3) Refrigerant pipe wall thickness and material

- Select refrigerant pipes of the table shown on the right wall thickness and material as specified for each pipe size.

NOTE ● Select pipes having a wall thickness larger than the specified minimum pipe thickness.

4) On-site piping work

IMPORTANT Take care so that installed pipes may not touch components within a unit. If touching with an internal component, it will generate abnormal sounds and/or vibrations.

How to remove the side cover Please remove the screw of a side cover and remove to the front.

- Carry out the on site piping work with the operation valve fully closed.
- Give sufficient protection to a pipe end (compressed and blazed, or with an adhesive tape) so that water or foreign matters may not enter the piping.
- Bend a pipe to a radius as large as practical.(R100-R150) Do not bend a pipe repeatedly to correct its form.
- Flare connection is used between the unit and refrigerant pipe. Flare a pipe after engaging a flare nut onto it. Flare dimensions for R410A are different from those for conventional R407C. Although we recommend the use of flaring tools designed specifically for R410A, conventional flaring tools can also be used by adjusting the measurement of protrusion B with a protrusion control gauge.
- The pipe should be anchored every 1.5m or less to isolate the vibration.
- Tighten a flare joint securely with a double spanner.

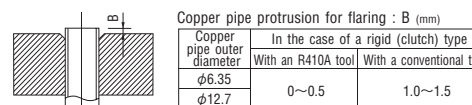
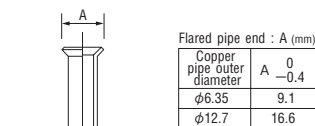
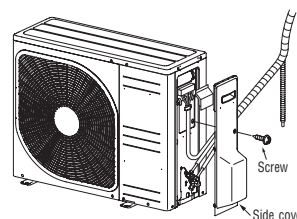

CAUTION Do not apply force beyond proper fastening torque in tightening the flare nut.

Fix both liquid and gas operation valves at the valve main bodies as illustrated on the right, and then fasten them, applying appropriate fastening torque.

Operation valve size (mm)	Tightening torque (N·m)	Tightening angle (°)	Recommended length of a tool handle (mm)
φ6.35 (1/4")	14~18	45~60	150
φ12.7 (1/2")	49~61	30~45	250

Do not hold the valve cap area with a spanner.

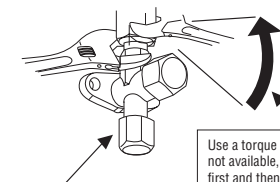

Use a torque wrench. If a torque wrench is not available, fasten the flare nut manually first and then tighten it further, using the left table as a guide.

5) Air tightness test

- ① Although outdoor and indoor units themselves have been tested for air tightness at the factory, check the connecting pipes after the installation work for air tightness from the operation valve's check joint equipped on the outdoor unit side. While conducting a test, keep the operation valve shut all the time.
 - a) Raise the pressure to 0.5 MPa, and then stop. Leave it for five minutes to see if the pressure drops.
 - b) Then raise the pressure to 1.5 MPa, and stop. Leave it for five more minutes to see if the pressure drops.
 - c) Then raise the pressure to the specified level (4.15 MPa), and record the ambient temperature and the pressure.
 - d) If no pressure drop is observed with an installation pressurized to the specified level and left for about one day, it is acceptable. When the ambient Temperature fall 1°C, the pressure also fall approximately 0.01 MPa. The pressure, if changed, should be compensated for.
 - e) If a pressure drop is observed in checking e) and a) – d), a leak exists somewhere. Find a leak by applying bubble test liquid to welded parts and flare joints and repair it. After repair, conduct an air-tightness test again.
- ② In conducting an air-tightness test, use nitrogen gas and pressurize the system with nitrogen gas from the gas side. Do not use a medium other than nitrogen gas under any circumstances.

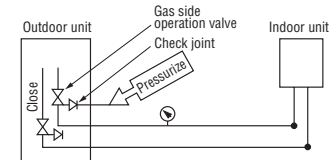

6) Evacuation

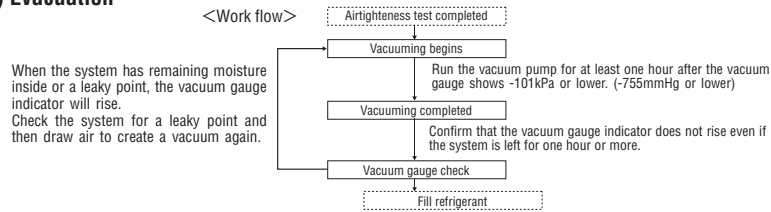

Pay attention to the following points in addition to the above for the R410A and compatible machines.

- To prevent a different oil from entering, assign dedicated tools, etc. to each refrigerant type. Under no circumstances must a gauge manifold and a charge hose in particular be shared with other refrigerant types (R22, R407C, etc.).
- Use a counterflow prevention adapter to prevent vacuum pump oil from entering the refrigerant system.

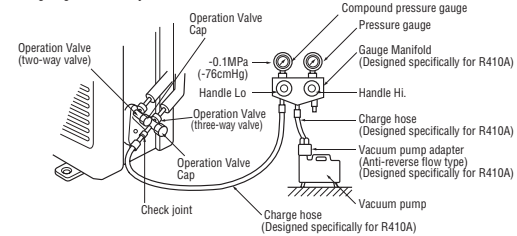

Securely tighten the operation valve cap and the check joint blind nut after adjustment.

Operation valve size (mm)	Operation valve cap tightening torque (N·m)	Check joint blind nut tightening torque (N·m)
φ6.35 (1/4")	20~30	10~12
φ12.7 (1/2")	25~35	

7) Additional refrigerant charge

- (1) Calculate a required refrigerant charge volume from the following table.

Model	Additional charge volume (kg) per meter of refrigerant piping (liquid pipe φ 6.35)	Refrigerant volume charged for shipment at the factory (kg)	Installation's pipe length (m) covered without additional refrigerant charge
Model 40, 50, 60	0.02	1.40	15

- This unit contains factory charged refrigerant covering 15m of refrigerant piping and additional refrigerant charge on the installation site is not required for an installation with up to 15m refrigerant piping.
When refrigerant piping exceeds 15m, additionally charge an amount calculated from the pipe length and the above table for the portion in excess of 15m.
- If an existing pipe system is used, a required refrigerant charge volume will vary depending on the liquid pipe size.
For further information, please see "5. UTILIZATION OF EXISTING PIPING."

Formula to calculate the volume of additional refrigerant required

$$\text{Additional charge volume (kg)} = \{ \text{Main length (m)} - \text{Factory charged volume 15 (m)} \} \times 0.02 \text{ (kg/m)}$$

*When an additional charge volume calculation result is negative, it is not necessary to charge refrigerant additionally.

- For an installation measuring 15 m or shorter in pipe length, please charge the refrigerant volume charged for shipment at the factory, when you recharge refrigerant after servicing etc.

8) Heating and condensation prevention

- (1) Dress refrigerant pipes (both gas and liquid pipes) for heat insulation and prevention of dew condensation.
 - Improper heat insulation/anti-dew dressing can result in a water leak or dripping causing damage to household effects, etc.
- (2) Use a heat insulating material that can withstand 120°C or a higher temperature. Poor heat insulating capacity can cause heat insulation problems or cable deterioration.
 - All gas pipes must be securely heat insulated in order to prevent damage from dripping water that comes from the condensation formed on them during a cooling operation or personal injury from burns because their surface can reach quite a high temperature due to discharged gas flowing inside during a heating operation.
 - Wrap indoor units' flare joints with heat insulating parts (pipe cover) for heat insulation (both gas and liquid pipes).
 - Give heat insulation to both gas and liquid side pipes. Bundle a heat insulating material and a pipe tightly together so that no gaps may be left between them and wrap them together with a connecting cable by a dressing tape.
 - **Both gas and liquid pipes need to be dressed with 20 mm or thicker heat insulation materials above the ceiling where relative humidity exceeds 70%.**

- (2) Charging refrigerant

- Since R410A refrigerant must be charged in the liquid phase, you should charge it, keeping the container cylinder upside down or using a refrigerant cylinder equipped with a siphon tube.
- Charge refrigerant always from the liquid side service port with the operation valve shut. When you find it difficult to charge a required amount, fully open the outdoor unit valves on both liquid and gas sides and charge refrigerant from the gas (suction) side service port, while running the unit in the cooling mode. In doing so, care must be taken so that refrigerant may be discharged from the cylinder in the liquid phase all the time. When the cylinder valve is throttled down or a dedicated conversion tool to change liquid-phase refrigerant into mist is used to protect the compressor, however, adjust charge conditions so that refrigerant will gasify upon entering the unit.
- In charging refrigerant, always charge a calculated volume by using a scale to measure the charge volume.
- When refrigerant is charged with the unit being run, complete a charge operation within 30 minutes.
Running the unit with an insufficient quantity of refrigerant for a long time can cause a compressor failure.

NOTE Put down the refrigerant volume calculated from the pipe length onto the caution label attached on the back side of the service panel.

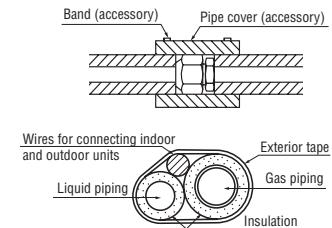

3. DRAIN PIPING WORK

- Execute drain piping by using a drain elbow and drain grommets supplied separately as optional parts, where water drained from the outdoor unit is a problem.
- Water may drip where there is a larger amount of drain water. Seal around the drain elbow and drain grommets with putty or adequate caulking material.
- Condensed water may flow out from vicinity of operation valve or connected pipes.
- Where you are likely to have several days of sub-zero temperatures in a row, do not use a drain elbow and drain grommets. (There is a risk of drain water freezing inside and blocking the drain.)

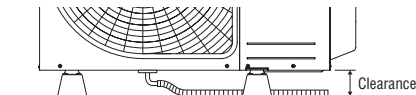
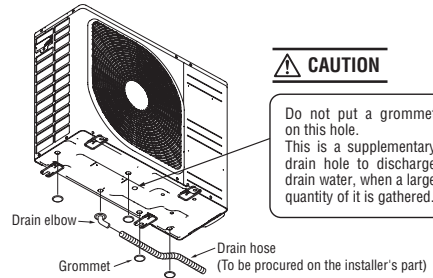

- When condensed water needs to be led to a drain, etc., install the unit on a flat base (supplied separately as an optional part) or concrete blocks. Then, please secure space for the drain elbow and the drain hose.

4. ELECTRICAL WIRING WORK For details of electrical cabling, refer to the indoor unit installation manual.

- Electrical installation work must be performed by an electrical installation service provider qualified by a power provider of the country. Electrical installation work must be executed according to the technical standards and other regulations applicable to electrical installations in the country.
- Do not use any supply cord lighter than one specified in parentheses for each type below.
 - braided cord (code designation 60245 IEC 51).
 - ordinary tough rubber sheathed cord (code designation 60245 IEC 53)
 - flat twin tinsel cord (code designation 60227 IEC 41);
 Use polychloroprene sheathed flexible cord (code designation 60245 IEC57) for supply cords of parts of appliances for outdoor use.
 - Ground the unit. Do not connect the grounding wire to a gas pipe, water pipe, lightning rod or telephone grounding wire. If improperly grounded, an electric shock or malfunction may result.
 - A grounding wire must be connected before connecting the power cable. Provide a grounding wire longer than the power cable.
 - The installation of an impulse withstanding type earth leakage breaker is necessary. A failure to install an earth leakage breaker can result in an accident such as an electric shock or a fire.
 - Do not turn on the power until the electrical work is completed.
 - Do not use a condensive capacitor for power factor improvement under any circumstances. (It does not improve power factor, while it can cause an abnormal overheat accident)
 - For power supply cables, use conduits.
 - Do not lay electronic control cables (remote control and signaling wires) and other cables together outside the unit. Laying them together can result in the malfunctioning or a failure of the unit due to electric noises.
 - Fasten cables so that they may not touch the piping, etc.
 - When cables are connected, make sure that all electrical components within the electrical component box are free of loose connector coupling or terminal connection and then attach the cover securely. (Improper cover attachment can result in malfunctioning or a failure of the unit, if water penetrates into the box.)
 - Always use a three-core cable for an indoor-outdoor connecting cable. Never use a shield cable.

CAUTION

In case of faulty wiring connection, the indoor unit stops, and then the run lamp turns on and the timer lamp blinks.

Use cables for interconnection wiring to avoid loosening of the wires. CENELEC code for cables Required field cables.

- H05RNR4G1.5 (Example) or 245IEC57
- H Harmonized cable type
 - 05 300/500 volts
 - R Natural-and/or synth. rubber wire insulation
 - N Polychloroprene rubber conductors insulation
 - R Stranded core
 - 4or5 Number of conductors
 - G One conductor of the cable is the earth conductor (yellow/green)
 - 1.5 Section of copper wire (mm²)

Power cable, indoor-outdoor connecting wires

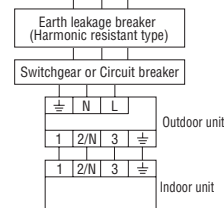
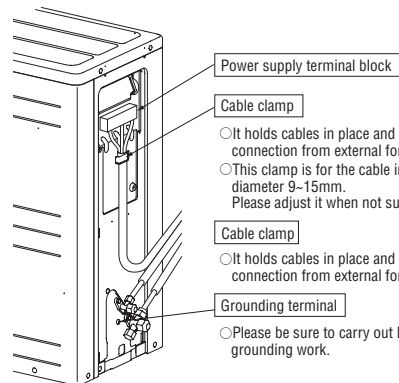

- Always perform grounding system installation work with the power cord unplugged.
- Connect a pair bearing a common terminal number with an indoor-outdoor connecting wire.
- In cabling, fasten cables securely with cable clamps so that no external force may work on terminal connection.
- Grounding terminals are provided in the control box.

CAUTION

Always use an earth leakage circuit breaker designed for inverter circuits to prevent a faulty operation.

Phase	Model	Earth leakage breaker	Switchgear or Circuit Breaker		Power source (minimum)	Interconnecting and grounding wires (minimum)
			Switch breaker	Over current protector rated capacity		
Single-phase	40	15A,30mA, 0.1sec or less	30A	16A	2.0mm ²	1.5mm×4
	50					
	60					

- The specifications shown in the above table are for units without heaters. For units with heaters, refer to the installation instructions or the construction instructions of the indoor unit.
- Switchgear or Circuit breaker capacity which is calculated from MAX. over current should be chosen along the regulations in each country.
- The cable specifications are based on the assumption that a metal or plastic conduit is used with no more than three cables contained in a conduit and a voltage drop is 2%. For an installation falling outside of these conditions, please follow the internal cabling regulations. Adapt it to the regulation in effect in each country.

5. UTILIZATION OF EXISTING PIPING

Check whether an existing pipe system is reusable or not by using the following flow chart.

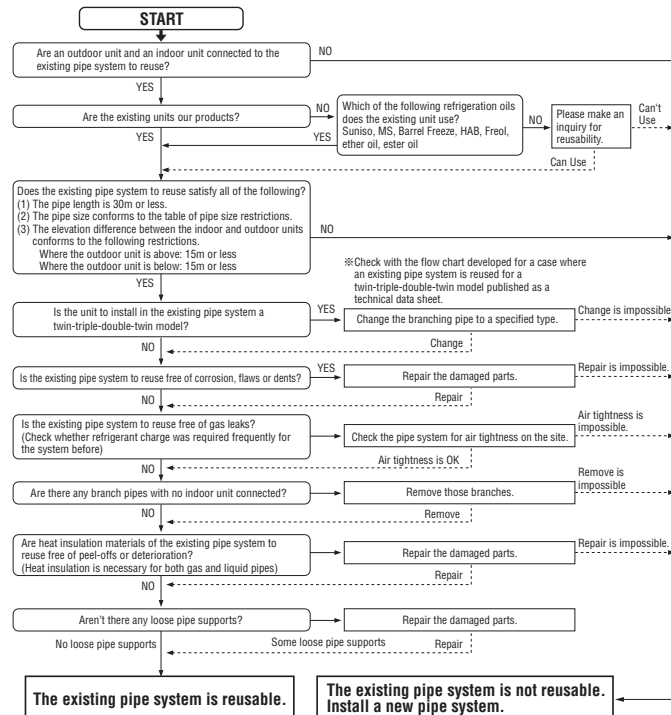

<Table of pipe size restrictions>

○:Standard pipe size ◐:Usable △:Restricted to shorter pipe length limits

Pipe size	Additional charge volume per meter of pipe		
	0.02kg/m	0.06kg/m	
40	Liquid pipe	ø6.35	ø9.52
	Gas pipe	ø12.7	ø12.7
	Usability	○	△
	Maximum one-way pipe length	30	10
Length covered without additional charge		15	5
50	Usability	◐	△
	Maximum one-way pipe length	30	10
	Length covered without additional charge		15
60	Usability	◐	△
	Maximum one-way pipe length	30	10
	Length covered without additional charge		15

- Please consult with our distributor in the area, if you need to recover refrigerant and charge it again.
- Any combinations of pipe sizes not listed in the table are not usable.

Formula to calculate additional charge volume

$$\text{Additional charge volume (kg)} = (\text{Main pipe length (m)} - \text{Length covered without additional charge shown in the table (m)}) \times \text{Additional charge volume per meter of pipe shown in the table (kg/m)}$$

※ If you obtain a negative figure as a result of calculation, no additional refrigerant needs to be charged.

Example When an 60 is installed in a 10m long existing pipe system (liquid ø9.52, gas ø12.7), the quantity of refrigerant to charge additionally should be (10m-5m) x 0.06kg/m = 0.3 kg.



<Where the existing unit can be run for a cooling operation.>

Carry out the following steps with the existing unit (in the order of (1), (2), (3) and (4))

- Run the unit for 30 minutes for a cooling operation.
- Stop the indoor fan and run the unit for 3 minutes for a cooling operation (returning liquid)
- Close the liquid side operation valve of the outdoor unit and pump down (refrigerant recovery)
- Blow with nitrogen gas. ※ If discolored refrigeration oil or any foreign matters is discharged by the blow, wash the pipe system or install a new pipe system.

- For the flare nut, do not use the old one, but use the one supplied with the outdoor unit. Process a flare to the dimensions specified for R410A.

<Where the existing unit cannot be run for a cooling operation.>

Wash the pipe system or install a new pipe system.

- If you choose to wash the pipe system, please contact our distributor in the area.

INSTALLATION TEST CHECK POINTS

Check the following points again after completion of the installation, and before turn on the power. Conduct a test run again and ensure that the unit operates properly. Explain to the customer how to use the unit and how to take care of the unit following the instruction manual.

After installation

- | | |
|--|---|
| <input type="checkbox"/> Power cables and connecting wires are securely fixed to the terminal block. | <input type="checkbox"/> The pipe joints for indoor and outdoor pipes have been insulated. |
| <input type="checkbox"/> The power supply voltage is correct as the rating. | <input type="checkbox"/> The reverse flow check cap is attached. |
| <input type="checkbox"/> The drain hose is fixed securely. | <input type="checkbox"/> The cover of the pipe cover (A) faces downward to prevent rain from entering. |
| <input type="checkbox"/> Operational valve is fully open. | <input type="checkbox"/> Gaps are properly sealed between the pipe covers (A) (B) and the wall surface / pipes. |
| <input type="checkbox"/> No gas leaks from the joints of the operational valve. | |







PSB012D909G 

(b) Model FDC71VN

Inverter driven single split PAC
71V
Designed for R410A refrigerant

- ⦿ This installation manual deals with outdoor units and general installation specifications only. For indoor units, refer to the respective installation manuals supplied with the units.
- ⦿ When install the unit, be sure to check whether the selection of installation place, power supply specifications, usage limitation (piping length, height differences between indoor and outdoor units, power supply voltage and etc.) and installation spaces

SAFETY PRECAUTIONS



- We recommend you to read this "SAFETY PRECAUTIONS" carefully before the installation work in order to gain full advantage of the functions of the unit and to avoid malfunction due to mishandling.
 - The precautions described below are divided into  **WARNING** and  **CAUTION**. The matters with possibilities leading to serious consequences such as death or serious personal injury due to erroneous handling are listed in the  **WARNING** and the matters with possibilities leading to personal injury or damage of the unit due to erroneous handling including probability leading to serious consequences in some cases are listed in  **CAUTION**. **These are very important precautions for safety. Be sure to observe all of them without fail.**
 - The meaning of "Marks" used here are as shown below.
-  Never do it under any circumstance.   Always do it according to the instruction
- Be sure to confirm no anomaly on the equipment by commissioning after completed installation and explain the operating methods as well as the maintenance methods of this equipment to the user according to the owner's manual.
 - Keep the installation manual together with owner's manual at a place where any user can read at any time. Moreover if necessary, ask to hand them to a new user

Check before installation

- Model name and power source
- Refrigerant piping length
- Piping, wiring and miscellaneous parts
- Indoor unit installation manual



WARNING

<p> Installation must be carried out by the qualified installer. If you install the system by yourself, it may cause serious trouble such as water leaks, electric shocks, fire and personal injury, as a result of a system malfunction.</p> <p>● Install the system in full accordance with the instruction manual. Incorrect installation may cause bursts, personal injury, water leaks, electric shocks and fire.</p> <p>● Use the original accessories and the specified components for installation. If parts other than those prescribed by us are used, it may cause fall of the unit, water leaks, electric shocks, fire, refrigerant leak, standard performance, control failure and personal injury.</p> <p>● When installing in small rooms, take prevention measures not to exceed the density limit of refrigerant in the event of leakage accordance with ISO5149. Consult the expert about prevention measures. If the density of refrigerant exceeds the limit in the event of leakage, lack of oxygen can occur, which can cause serious accidents.</p> <p>● Ventilate the working area well in the event of refrigerant leakage during installation. If the refrigerant comes into contact with naked flames, poisonous gas is produced.</p> <p>● After completed installation, check that no refrigerant leaks from the system. If refrigerant leaks into the room and comes into contact with an oven or other hot surface, poisonous gas is produced.</p> <p>● Hang up the unit at the specified points with ropes which can support the weight in lifting for portage. And to avoid jolting out of alignment, be sure to hang up the unit at 4-point support. An improper manner of portage such as 3-point support can cause death or serious personal injury due to falling of the unit</p> <p>● Install the unit in a location with good support. Unsuitable installation locations can cause the unit to fall and cause material damage and personal injury.</p> <p>● Ensure the unit is stable when installed, so that it can withstand earthquakes and strong winds. Unsuitable installation locations can cause the unit to fall and cause material damage and personal injury.</p> <p>● The electrical installation must be carried out by the qualified electrician in accordance with "the norm for electrical work" and "national wiring regulation", and the system must be connected to the dedicated circuit. Power supply with insufficient capacity and incorrect function done by improper work can cause electric shocks and fire.</p> <p>● Be sure to shut off the power before starting electrical work. Failure to shut off the power can cause electric shocks, unit failure or incorrect function of equipment.</p> <p>● Be sure to use the cables conformed to safety standard and cable ampacity for power distribution work. Unconformable cables can cause electric leak, anomalous heat production or fire.</p> <p>● Use the prescribed cables for electrical connection, tighten the cables securely in terminal block and relieve the cables correctly to prevent overloading the terminal blocks. Loose connections or cable mountings can cause anomalous heat production or fire.</p> <p>● Arrange the wiring in the control box so that it cannot be pushed up further into the box. Install the service panel correctly. Incorrect installation may result in overheating and fire.</p>	<p> Do not perform brazing work in the airtight room It can cause lack of oxygen.</p> <p>● Use the prescribed pipes, flare nuts and tools for R410A. Using existing parts (for R22 or R407C) can cause the unit failure and serious accidents due to burst of the refrigerant piping.</p> <p>● Tighten the flare nut by using double spanners and torque wrench according to prescribed method. Be sure to tighten the flare nut too much. Loose flare connection or damage on the flare part by tightening with excess torque can cause burst or refrigerant leakage, which may result in lack of oxygen.</p> <p>● Do not open the service valves for liquid line and gas line until completed refrigerant piping work, air tightness test and evacuation. If the compressor is operated in state of opening service valves before completed connection of refrigerant piping, frost bite or injury from an abrupt refrigerant outflow and air can be sucked into refrigerant circuit, which may result in personal injury due to anomalously high pressure in the refrigerant circuit.</p> <p>● Only use prescribed optional parts. The installation must be carried out by the qualified installer. If you install the system by yourself, it can cause serious trouble such as water leaks, electric shocks, fire.</p> <p>● Do not perform any change of protective device itself or its setup condition The forced operation by short-circuiting protective device of pressure switch and temperature controller or the specified component can cause fire or burst.</p> <p>● Be sure to switch off the power supply in the event of installation, inspection or servicing. If the power supply is not shut off, there is a risk of electric shocks, unit failure or personal injury due to the unexpected operation.</p> <p>● Consult the dealer or an expert regarding removal of the unit. Incorrect installation can cause water leaks, electric shocks or fire.</p> <p>● Stop the compressor before closing valve and disconnecting refrigerant pipes in case of pump down operation. If disconnecting refrigerant pipes in state of opening service valves before compressor stopping, you may incur injury from an abrupt refrigerant outflow and air can be sucked, which can cause burst or personal injury due to high pressure in the refrigerant circuit</p> <p> Ensure that no air enters in the refrigerant circuit when the unit is installed and removed. If air enters in the refrigerant circuit, the pressure in the refrigerant circuit becomes too high, which can cause personal injury.</p> <p>● Do not run the unit with removed panels or protections Touching rotating equipments, hot surfaces or high voltage parts can cause personal injury due to entrapment, burn or electric shocks.</p> <p>● Be sure to fix up the service panels. Incorrect fixing can cause electric shocks or fire due to intrusion of dust or water.</p> <p>● Do not perform any repairs or modifications by yourself. Consult the dealer if the unit requires repair. If you repair or modify the unit, it can cause water leaks, electric shocks or fire.</p>
---	---

Бсе каталог и инструкции здесь: <http://splitoff.ru/ehh-doc.html>

Notabilia as a unit designed for R410A

- Do not use any refrigerant other than R410A. R410A will rise to pressure about 1.6 times higher than that of a conventional refrigerant. A cylinder containing R410A has a pink indication mark on the top.
- A unit designed for R410A has adopted a different size indoor unit operation valve charge port and a different size check joint provided in the unit to prevent the charging of a wrong refrigerant by mistake. The processed dimension of the flared part of a refrigerant pipe and a flare nut's parallel side measurement have also been altered to raise strength against pressure. Accordingly, you are required to arrange dedicated R410A tools listed in the table on the right before installing or servicing this unit.
- Do not use a charge cylinder. The use of a charge cylinder will cause the refrigerant composition to change, which results in performance degradation.
- In charging refrigerant, always take it out from a cylinder in the liquid phase.
- All indoor units must be models designed exclusively for R410A. Check connectable indoor unit models in a catalog, etc. (A wrong indoor unit, if connected into the system, will impair proper system operation)

Dedicated R410A tools	
a)	Gauge manifold
b)	Charge hose
c)	Electronic scale for refrigerant charging
d)	Torque wrench
e)	Flare tool
f)	Protrusion control copper pipe gauge
g)	Vacuum pump adapter
h)	Gas leak detector

1. HAULAGE AND INSTALLATION (Take particular care in carrying in or moving the unit, and always perform such an operation with two or more persons.)

⚠ CAUTION

When a unit is hoisted with slings for haulage, take into consideration the offset of its gravity center position. If not properly balanced, the unit can be thrown off-balance and fall.

1) Delivery

- Deliver the unit as close as possible to the installation site before removing it from the packaging.
- When some compelling reason necessitates the unpacking of the unit before it is carried in, use nylon slings or protective wood pieces so as not to damage the unit by ropes lifting it.

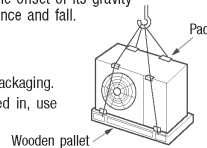

3) Selection of installation location for the outdoor unit

Be sure to select a suitable installation place in consideration of following conditions.

- A place where it is horizontal, stable and can endure the unit weight and will not allow vibration transmittance of the unit.
- A place where it can be free from possibility of bothering neighbors due to noise or exhaust air from the unit
- A place where the unit is not exposed to oil splashes.
- A place where it can be free from danger of flammable gas leakage.
- A place where drain water can be disposed without any trouble.
- A place where the unit will not be affected by heat radiation from other heat source.
- A place where snow will not accumulate.
- A place where the unit can be kept away 5m or more from TV set and/or radio receiver in order to avoid any radio or TV interference.
- A place where good air circulation can be secured, and enough service space can be secured for maintenance and service of the unit safely.
- A place where the unit will not be affected by electromagnetic waves and/or high-harmonic waves generated by other equipment.
- A place where chemical substances like sulfuric gas, chloric gas, acid and alkali (including ammonia), which can harm the unit, will not be generated and not remain.
- A place where strong wind will not blow against the outlet air blow of the unit.

4) Caution about selection of installation location

(1) If the unit is installed in the area where the snow will accumulate, following measures are required. The bottom plate of unit and intake, outlet may be blocked by snow.

1. Install the unit on the base so that the bottom is higher than snow cover surface.
2. Provide a snow hood to the outdoor unit on site. Regarding outline of a snow hood, refer to our technical manual.
3. Install the unit under eaves or provide the roof on site.

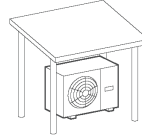
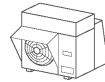
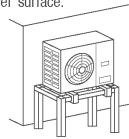

Since drain water generated by defrost control may freeze, following measures are required.

- Don't execute drain piping work by using a drain elbow and drain grommets (optional parts). [Refer to Drain piping work.]
- Recommend setting Defrost Control (SW3-1) and Snow Guard Fan Control (SW3-2). [Refer to Setting SW3-1, SW3-2.]

(2) If the unit can be affected by strong wind, following measures are required.

Strong wind can cause damage of fan (fan motor), or can cause performance degradation, or can trigger anomalous stop of the unit due to rising of high pressure.

1. Install the outlet air blow side of the unit to face a wall of building, or provide a fence or a windbreak screen.
2. Install the outlet air blow side of the unit in a position perpendicular to the direction of wind.
3. The unit should be installed on the stable and level foundation. If the foundation is not level, tie down the unit with wires.

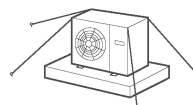
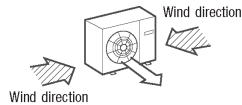
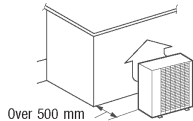

2) Portage

- The right hand side of the unit as viewed from the front (diffuser side) is heavier. A person carrying the right hand side must take heed of this fact. A person carrying the left hand side must hold with his right hand the handle provided on the front panel of the unit and with his left hand the corner column section.

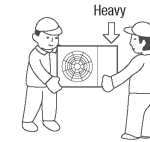

5) Installation space

- Walls surrounding the unit in the four sides are not acceptable.
- There must be a 1-meter or larger space in the above.
- When more than one unit are installed side by side, provide a 250mm or wider interval between them as a service space. In order to facilitate servicing of controllers, please provide a sufficient space between units so that their top plates can be removed easily.
- Where a danger of short-circuiting exists, install guide louvers.
- When more than one unit are installed, provide sufficient intake space consciously so that short-circuiting may not occur.
- Where piling snow can bury the outdoor unit, provide proper snow guards.

Size	71V (mm)		
	I	II	III
L1	Open	Open	500
L2	300	250	Open
L3	100	150	100
L4	250	250	250

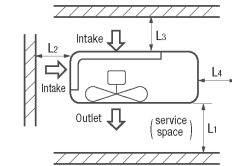

6) Installation

① Anchor bolt fixed position

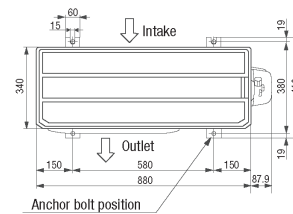

② Notabilia for installation

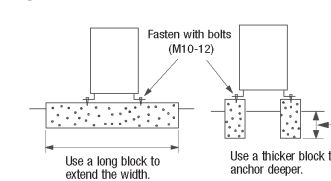

- In installing the unit, fix the unit's legs with bolts specified on the above.
- The protrusion of an anchor bolt on the front side must be kept within 15 mm.
- Securely install the unit so that it does not fall over during earthquakes or strong winds, etc.
- Refer to the above illustrations for information regarding concrete foundations.
- Install the unit in a level area. (With a gradient of 5 mm or less.)
Improper installation can result in a compressor failure, broken piping within the unit and abnormal noise generation.

7) To run the unit for a cooling operation, when the outdoor temperature is -5°C or lower.

- When the outdoor air temperature is -5°C or lower, provide a snow hood to the outdoor unit on site. So that strong wind will not blow against the outdoor heat exchanger directly. Regarding outline of a snow hood, refer to our technical manual.

2. REFRIGERANT PIPING WORK

1) Restrictions on unit installation and use

- Check the following points in light of the indoor unit specifications and the installation site.
- Observe the following restrictions on unit installation and use. Improper installation can result in a compressor failure or performance degradation.

Restrictions		Dimensional restrictions	Marks appearing in the drawing on the right	
Model 71V			Single type	Twin type
One-way pipe length of refrigerant piping	Main pipe length	50m or less	L	L1+L1+L2
			L	L
One-way pipe length after the first branching point		20m or less	—	L1, L2
Difference of pipe length after the first branching point		10m or less	—	L1—L2
Elevation difference between indoor and outdoor units	When the outdoor unit is positioned higher,	30m or less	H	H
	When the outdoor unit is positioned lower,	15m or less	H	H
Elevation difference between indoor units		0.5m or less	—	h



- The use restrictions appearing in the table above are applicable to the standard pipe size combinations shown in the table below. Where an existing pipe system is utilized, different one-way pipe length restrictions should apply depending on its pipe size. For more information, please see "6. UTILIZATION OF EXISTING PIPING."

2) Determination of pipe size

- Determine refrigerant pipe size pursuant to the following guidelines based on the indoor unit specifications.

		Model 71V	
		Gas pipe	Liquid pipe
Outdoor unit connected		φ15.88 Flare	φ9.52 Flare
Refrigerant piping (branch pipe)L		φ15.88	φ9.52
In the case of a single type	Indoor unit connected	φ15.88	φ9.52
	Capacity of indoor unit	Model 71V	
In the case of a twin type	Branching pipe set	DIS-WA1	
	Refrigerant piping (branch pipe L1,L2)	φ12.7	φ9.52
	Indoor unit connected	φ12.7	φ6.35
	Capacity of indoor unit	Model 40V×2	



- When the 40V model is connected as an indoor unit, always use a φ9.52 liquid pipe for the branch (branching pipe – indoor unit) and a different diameter joint supplied with the branching pipe set for connection with the indoor unit on the liquid pipe side.
- If a φ6.35 pipe is used for connection with a branching pipe, a refrigerant distribution disorder may occur, causing one of the indoor units to fall short of the rated capacity.
- A riser pipe must be a part of the main. A branching pipe set should be installed horizontally at a point as close to an indoor unit as possible.
- A branching part must be dressed with a heat-insulation material supplied as an accessory.
- For the details of installation work required at and near a branching area, see the installation manual supplied with your branching pipe set.

3) Refrigerant pipe wall thickness and material

- Select refrigerant pipes of the table shown on the right wall thickness and material as specified for each pipe size.

Pipe diameter [mm]	6.35	9.52	12.7	15.88
Minimum pipe wall thickness [mm]	0.8	0.8	0.8	1.0
Pipe material*	O-type pipe	O-type pipe	O-type pipe	O-type pipe



- Select pipes having a wall thickness less than the specified minimum pipe thickness.

*Phosphorus deoxidized seamless copper pipe C1220T, JIS

4) On-site piping work



- Take care so that installed pipes may not touch components within a unit. If touching with an internal component, it will generate abnormal sounds and/or vibrations.

How to remove the side cover

Please remove the screw of a side cover and remove to the front.

- Carry out the on site piping work with the operation valve fully closed.
- Give sufficient protection to a pipe end (compressed and brazed, or with an adhesive tape) so that water or foreign matters may not enter the piping.
- Bend a pipe to a radius as large as practical.(R100~R150) Do not bend a pipe repeatedly to correct its form.
- Flare connection is used between the unit and refrigerant pipe. Flare a pipe after engaging a flare nut onto it. Flare dimensions for R410A are different from those for conventional R407C. Although we recommend the use of flaring tools designed specifically for R410A, conventional flaring tools can also be used by adjusting the measurement of protrusion B with a protrusion control gauge.
- The pipe should be anchored every 1.5m or less to isolate the vibration.
- Tighten a flare joint securely with a double spanner.

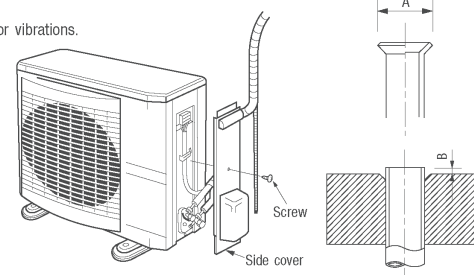

Flared pipe end: A (mm)	
Copper pipe outer diameter	A
φ6.35	9.1
φ9.52	13.2
φ12.7	16.6
φ15.88	19.7

Copper pipe protrusion for flaring: B (mm)		
Copper pipe outer diameter	In the case of a rigid (clutch) type	
	With an R410A tool	With a conventional
φ6.35	0~0.5	0.7~
φ9.52		
φ12.7		
φ15.88		

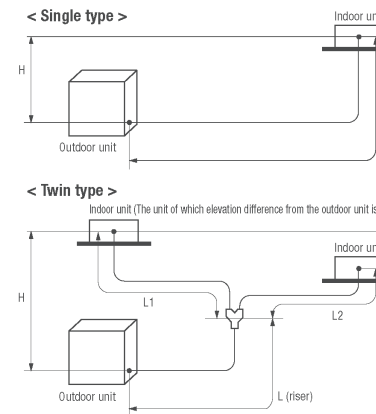

About brazing

Brazing must be performed under a nitrogen gas flow.

Without nitrogen gas, a large quantity of foreign matters (oxidized film) are created, causing a critical failure from capillary tube or expansion valve clogging.

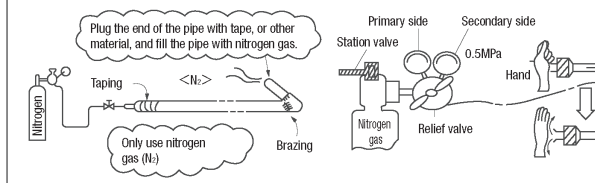



Do not apply force beyond proper fastening torque in tightening the flare nut.

Fix both liquid and gas service valves at the valve main bodies as illustrated on the right, and then fasten them, applying appropriate fastening torque.

Operation valve size (mm)	Tightening torque (N·m)	Tightening angle (°)	Recommended length of a tool handle (mm)
φ6.35 (1/4")	14~18	45~60	150
φ9.52 (3/8")	34~42	30~45	200
φ12.7 (1/2")	49~61	30~45	250
φ15.88(5/8")	68~82	15~20	300

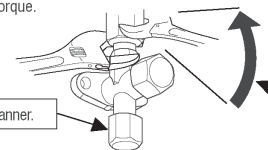

Do not hold the valve cap area with a spanner.

Use a torque wrench. If a torque wrench is not available, fasten the flare nut manually first and then tighten it further, using the left table as a guide.

5) Air tightness test

- Although outdoor and indoor units themselves have been tested for air tightness at the factory, check the connecting pipes after the installation work for air tightness from the operation valve's check joint equipped on the outdoor unit side. While conducting a test, keep the operation valve shut all the time.
 - Raise the pressure to 0.5 MPa, and then stop. Leave it for five minutes to see if the pressure drops.
 - Then raise the pressure to 1.5 MPa, and stop. Leave it for five more minutes to see if the pressure drops.
 - Then raise the pressure to the specified level (4.15 MPa), and record the ambient temperature and the pressure.
 - If no pressure drop is observed with an installation pressurized to the specified level and left for about one day, it is acceptable. When the ambient Temperature fall 1°C, the pressure also fall approximately 0.01 MPa. The pressure, if changed, should be compensated for.
 - If a pressure drop is observed in checking e) and a) – d), a leak exists somewhere. Find a leak by applying bubble test liquid to welded parts and flare joints and repair it. After repair, conduct an air-tightness test again.
- In conducting an air-tightness test, use nitrogen gas and pressurize the system with nitrogen gas from the gas side. Do not use a medium other than nitrogen gas under any circumstances.

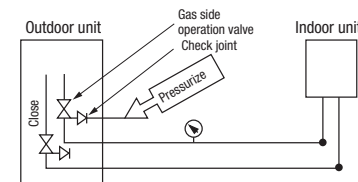

6) Evacuation

<Work flow>

When the system has remaining moisture inside or a leaky point, the vacuum gauge indicator will rise. Check the system for a leaky point and then draw air to create a vacuum again.

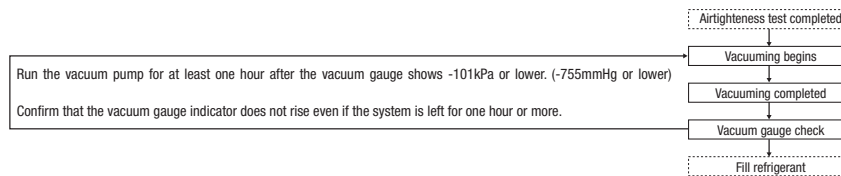

Pay attention to the following points in addition to the above for the R410A and compatible machines.

- To prevent a different oil from entering, assign dedicated tools, etc. to each refrigerant type. Under no circumstances must a gauge manifold and a charge hose in particular be shared with other refrigerant types (R22, R407C, etc.).
- Use a counterflow prevention adapter to prevent vacuum pump oil from entering the refrigerant system.

7) Additional refrigerant charge

- Calculate a required refrigerant charge volume from the following table.

	Standard refrigerant charge volume (kg)	Pipe length for standard refrigerant charge volume (m)	Additional charge volume (kg) per meter of refrigerant piping (liquid pipe φ6.35)	Refrigerant volume charged for shipment at the factory (kg)	Installation's pipe length (m) covered without additional refrigerant charge
Model 71V	2.35	20	0.06	2.95	30

- This unit contains factory charged refrigerant covering 30m of refrigerant piping and additional refrigerant charge on the installation site is not required for an installation with up to 30m refrigerant piping. When refrigerant piping exceeds 30m, additionally charge an amount calculated from the pipe length and the above table for the portion in excess of 30m.
- When refrigerant piping is shorter than 3m, reduce refrigerant by 1kg from the factory charged volume and adjust to 1.95kg.
- If an existing pipe system is used, a required refrigerant charge volume will vary depending on the liquid pipe size. For further information, please see "6. UTILIZATION OF EXISTING PIPING."

Formula to calculate the volume of additional refrigerant required

$$\text{Additional charge volume (kg)} = \{ \text{Main pipe length (m)} - \text{Length covered without additional charge 30 (m)} \} \times 0.06 \text{ (kg/m)} + \text{Total length of branch pipes (m)} \times 0.06 \text{ (kg/m)}$$

- For an installation measuring 3m or longer, but not more than 20m, in pipe length, please charge the standard refrigerant charge volume, when you recharge refrigerant after servicing etc.
- When refrigerant piping is shorter than 3m, recharge 1.95kg of refrigerant.
Ex.) For a 10m installation, charge 2.35 kg of refrigerant.
For a 25m installation, charge "2.35 + (25-20) x 0.06 = 2.65 kg."

(2) Charging refrigerant

- Since R410A refrigerant must be charged in the liquid phase, you should charge it, keeping the container cylinder upside down or using a refrigerant cylinder equipped with a siphon tube.
- Charge refrigerant always from the liquid side service port with the operation valve shut. When you find it difficult to charge a required amount, fully open the outdoor unit valves on both liquid and gas sides and charge refrigerant from the gas (suction) side service port, while running the unit in the cooling mode. In doing so, care must be taken so that refrigerant may be discharged from the cylinder in the liquid phase all the time. When the cylinder valve is throttled down or a dedicated conversion tool to change liquid-phase refrigerant into mist is used to protect the compressor, however, adjust charge conditions so that refrigerant will gasify upon entering the unit.
- In charging refrigerant, always charge a calculated volume by using a scale to measure the charge volume.
- When refrigerant is charged with the unit being run, complete a charge operation within 30 minutes. Running the unit with an insufficient quantity of refrigerant for a long time can cause a compressor failure.

NOTE Put down the refrigerant volume calculated from the pipe length onto the caution label attached on the back side of the service panel.

8) Heating and condensation prevention

- Dress refrigerant pipes (both gas and liquid pipes) for heat insulation and prevention of dew condensation.
 - Improper heat insulation/anti-dew dressing can result in a water leak or dripping causing damage to household effects, etc.
- Use a heat insulating material that can withstand 120°C or a higher temperature. Poor heat insulating capacity can cause heat insulation problems or cable deterioration.
 - All gas pipes must be securely heat insulated in order to prevent damage from dripping water that comes from the condensation formed on them during a cooling operation or personal injury from burns because their surface can reach quite a high temperature due to discharged gas flowing inside during a heating operation.
 - Wrap indoor units' flare joints with heat insulating parts (pipe cover) for heat insulation (both gas and liquid pipes).
 - Give heat insulation to both gas and liquid side pipes. Bundle a heat insulating material and a pipe tightly together so that no gaps may be left between them and wrap them together with a connecting cable by a dressing tape.
 - Although it is verified in a test that this air conditioning unit shows satisfactory performance under JIS condensation test conditions, **both gas and liquid pipes need to be dressed with 20 mm or thicker heat insulation materials above the ceiling where relative humidity exceeds 70%.**

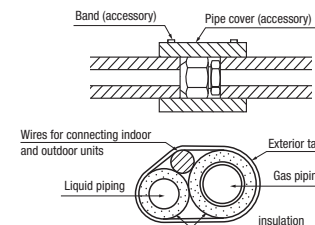

3. DRAIN PIPING WORK

- Execute drain piping by using a drain elbow and drain grommets supplied separately as optional parts, where water drained from the outdoor unit is a problem.

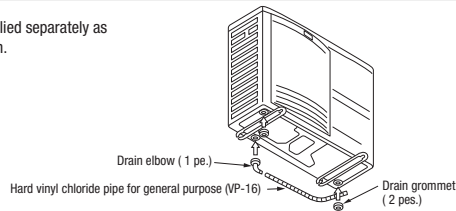

- There are 3 drain holes provided on the bottom plate of an outdoor unit to discharge condensed water.
- When condensed water needs to be led to a drain, etc., install the unit on a (supplied separately as an optional part) or concrete blocks.
- Connect a drain elbow as shown in the illustration and close the other two drain h grommets.

4. ELECTRICAL WIRING WORK

For details of electrical cabling, refer to the indoor unit installation manual.

Electrical installation work must be performed by an electrical installation service provider qualified by a power provider of the country. Electrical installation work must be executed according to the technical standards and other regulations applicable to electrical installations in the country.

- Do not use any supply cord lighter than one specified in parentheses for each type below.
 - braided cord (code designation 60245 IEC 51),
 - ordinary tough rubber sheathed cord (code designation 60245 IEC 53)
 - flat twin tinsel cord (code designation 60227 IEC 41);
- Do not use anything lighter than polychloroprene sheathed flexible cord (code designation 60245 IEC57) for supply cords of parts of appliances for outdoor use.
- Ground the unit. Do not connect the grounding wire to a gas pipe, water pipe, lightning rod or telephone grounding wire.
 - If improperly grounded, an electric shock or malfunction may result.
- A grounding wire must be connected before connecting the power cable. Provide a grounding wire longer than the power cable.
- The installation of an impulse withstanding type earth leakage breaker is necessary. A failure to install an earth leakage breaker can result in an accident such as an electric shock or a fire.
- Do not turn on the power until the electrical work is completed.
- Do not use a condensive capacitor for power factor improvement under any circumstances. (It dose not improve power factor, while it can cause an abnormal overheat accident)
- For power supply cables, use conduits.
- Do not lay electronic control cables (remote control and signaling wires) and other cables together outside the unit. Laying them together can result in the malfunctioning or a failure of the unit due to electric noises.
- Fasten cables so that may not touch the piping, etc.
- When cables are connected, make sure that all electrical components within the electrical component box are free of loose connector coupling or terminal connection and then attach the cover securely. (Improper cover attachment can result in malfunctioning or a failure of the unit, if water penetrates into the box.)
- Always use a three-core cable for an indoor-outdoor connecting cable. Never use a shield cable.

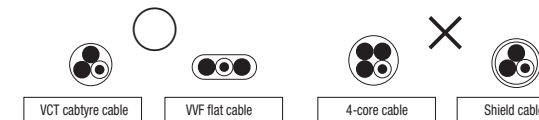

- Connect a pair bearing a common terminal number with an indoor-outdoor connecting v
- In cabling, fasten cables securely with cable clamps so that no external force may wo terminal connections.
- Grounding terminals are provided in the control box.

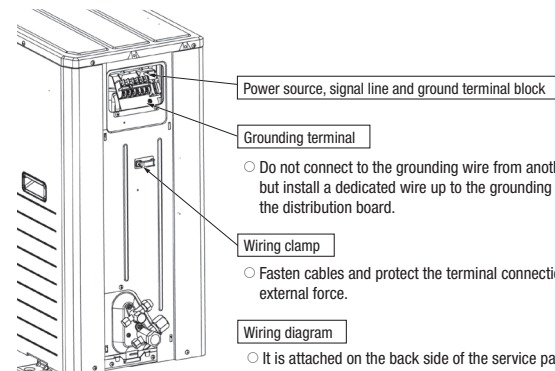

Power cable, indoor-outdoor connecting wires

- Always perform grounding system installation work with the power cord unplugged.

CAUTION Always use an earth leakage circuit breaker designed for inverter circuits to prevent a faulty operation.

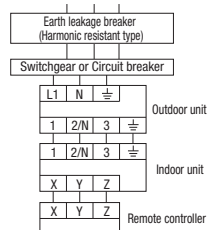

Model	Power source	Power cable thickness (mm ²)	MAX. over current (A)	Cable length (m)	Grounding wire thickness	Indoor-outdoor wire thickness X number
71V	Single phase 3 wire 220-240V 50Hz	3.5	17	21	φ1.6mm	φ1.6mm x 3

- The specifications shown in the above table are for units without heaters. For units with heaters, refer to the installation instructions or the construction instructions of the indoor unit.
- Switchgear or Circuit breaker capacity which is calculated from MAX. over current should be chosen along the regulations in each country.
- The cable specifications are based on the assumption that a metal or plastic conduit is used with no more than three cables contained in a conduit and a voltage drop is 2%. For an installation falling outside of these conditions, follow the internal cabling regulations. Adapt it to the regulation in effect in each country.

5. TEST RUN

WARNING

- Before conduct a test run, do not fail to make sure that the operation valves are closed.
- Turn on power 6 hours prior to a test run to energize the crank case heater.
- In case of the first operation after turning on power, even if the unit does not move for 30 minutes, it is not a breakdown.
- Always give a 3-minute or longer interval before you start the unit again whenever it is stopped.
- Removing the service panel will expose high-voltage live parts and high-temperature parts, which are quite dangerous. Take utmost care not to incur an electric shock or burns. Do not leave the unit with the service panel open.

A failure to observe these instructions can result in a compressor breakdown.

CAUTION

- When you operate switches for on-site setting, be careful not to touch a live part.
- You cannot check discharge pressure from the liquid operation valve charge port.
- The 4-way valve (20S) is energized during a heating operation.
- When power supply is cut off to reset the unit, give 3 or more minutes before you turn on power again after power is cut off. If this procedure is not observed in turning on power again, "E-5" (Communication error) may occur.

About insulation resistance

- An insulation resistance value may drop to several M ohms immediately after installation or when the unit is left for a long time without power, because refrigerant is gathered in the compressor. When the earth-leakage breaker is actuated due to low insulation resistance, please check the following:
 - (1) Check whether a normal insulation resistance value is restored about 6 hours after power is turned. Turning on power will energize the compressor and heat it to evaporate refrigerant gathered in it.
 - (2) Check whether the earth-leakage breaker is a harmonic resistant type. This unit is equipped with an inverter and therefore, the use of a harmonic resistant type earth-leakage breaker is necessary to prevent a false actuation.

1) Test run method

Please remove a side cover.

- (1) A test run can be initiated from an outdoor unit by using SW5-4 and SW5-4 for on-site setting.
- (2) Switching SW3-3 to ON will start the compressor.
- (3) The unit will start a cooling operation, when SW5-4 is OFF, or a heating operation, when SW5-4 is ON.
- (4) **Do not fail to switch SW5-3 to OFF when a test run is completed.**

※ **In case of the first operation after turning on the power supply, when the unit runs in the cooling mode at outside temperature 5°C or lower, it automatically changes into the cooling mode after it runs in the heating mode for 10 minutes.**

SW-3-3	SW-3-4	
ON	OFF	Cooling during a test run
OFF	ON	Heating during a test run
OFF	—	Normal or After the test operation

Items to check before a test run

- When you leave the outdoor unit with power supplied to it, be sure to close the panel.

Item No. used in the installation manual	Item	Check item	Check
2	Refrigerant plumbing	Is brazed, was it brazed under a nitrogen gas flow?	
		Were air-tightness test and vacuum extraction surely performed?	
		Are heat insulation materials installed on both liquid and gas pipes?	
		Are operation valves surely opened for both liquid and gas systems?	
		Have you recorded the additional refrigerant charge volume and refrigerant pipe length on the panel's label?	
4	Electric wiring	Is the unit free of cabling errors such as uncompleted connection, an absent or reversed phase?	
		Are properly rated electrical equipments used for circuit breakers and cables?	
		Doesn't cabling cross-connect between units, where more than one unit are installed?	
		Are n't indoor-outdoor signal wires connected to remote control wires?	
		Do indoor-outdoor connecting cables connect between the same terminal numbers?	
		Are either VCT cabletype cables or WF flat cables used for indoor-outdoor connecting cables?	
		Does grounding satisfy the D type grounding (type III grounding) requirements?	
		Is the unit grounded with a dedicated grounding wire not connected to another unit's grounding wire?	
		Are cables free of loose screws at their connection points?	
		Are cables held down with cable clamps so that no external force works onto terminal connections?	
—	Indoor unit	Is indoor unit installation work completed?	
		Where a face cover should be attached onto an indoor unit, is the face cover attached to the indoor unit?	

2) Checking the state of the unit in operation

Please remove a service panel.

Use check joints provided on the piping before and after the four-way valve installed inside the outdoor unit for checking discharge pressure and suction pressure. As indicated in the table shown on the right, pressure detected at each point will vary depending on whether a cooling or heating operation has been selected.

	Check joint of the pipe	Charge port of the gas operation valve
Cooling operation	Discharge pressure (High pressure)	Suction pressure (Low pressure)
Heating operation	Suction pressure (Low pressure)	Discharge pressure (High pressure)

3) Setting SW3-1, SW3-2.

Please remove a service panel.

- (1) Defrost control switching (SW3-1)
 - When this switch is turned ON, the unit will run in the defrost mode more frequently.
 - Set this switch to ON, when installed in a region where outdoor temperature falls below zero during the season the unit is run for a heating operation.
- (2) Snow guard fan control (SW3-2)
 - When this switch is turned on, the outdoor unit fan will run for 30 seconds in every 10 minutes, when outdoor temperature falls to 3°C or lower and the compressor is not running.
 - When the unit is used in a very snowy country, set this switch to ON.

4) Failure diagnosis in a test run

Error indicated on the remote control unit	Printed circuit board LED (The cycles of 5 seconds)		Failure event	Action
	Red LED	Green LED		
E34	Blinking once	Blinking continuously	Open phase	Check power cables for loose contact or disconnection
E40	Blinking once	Blinking continuously	63H1 actuation or operation with operation valves shut (occurs mainly during a heating operation)	1. Check whether the operation valves are open. 2. If an error has been canceled when 3 minutes have elapsed since a compressor stop, you can restart the unit by effecting Check Reset from the remote control unit.
E49	Blinking once	Blinking continuously	Low pressure error or operation with operation valves shut (occurs mainly during a cooling operation)	

- If an error code other than those listed above is indicated, refer to the wiring diagram of the outdoor unit and the indoor unit.

5) The state of the electronic expansion valve.

The following table illustrates the steady states of the electronic expansion valve.

	When power is turned on	When the unit comes to a normal stop		When the unit comes to an abnormal stop	
		During a cooling operation	During a heating operation	During a cooling operation	During a heating operation
Valve for a cooling operation	Complete shut position	Complete shut position	Full open position	Full open position	Full open position
Valve for a heating operation	Full open position	Full open position	Complete shut position	Full open position	Full open position

6) Heed the following on the first operation after turning on the circuit breaker.

This outdoor unit may start in the standby mode (waiting for a compressor startup), which can continue up to 30 minutes, to prevent the oil level in the compressor from lowering on the first operation after turning on the circuit breaker. If that is the case, do not suspect a unit failure.

Test run procedure

- Always carry out a test run and check the following in order as listed.

Turn	The contents of operation	Check
①	Open the gas side operation valve fully.	
②	Open the liquid side operation valve fully.	
③	Close the panel.	
④	Where a remote control unit is used for unit setup on the installation site, follow instructions for unit setup on the installation site with a remote control unit.	
⑤	SW5-3 / SW5-4 OFF: the unit will start a cooling operation. SW5-3 / SW5-4 ON: the unit will start a heating operation.	
⑥	When the unit starts operation, press the wind direction button provided on the remote control unit to check its operation.	
⑦	Place your hand before the indoor unit's diffuser to check whether cold (warm) winds come out in a cooling (heating) operation.	
⑧	Make sure that a red LED is not blinking.	
⑨	When you complete the test run, please turn on SW5-3 for 1 second and be sure to end a test run.	
⑩	Where options are used, check their operation according to the respective instruction manuals.	

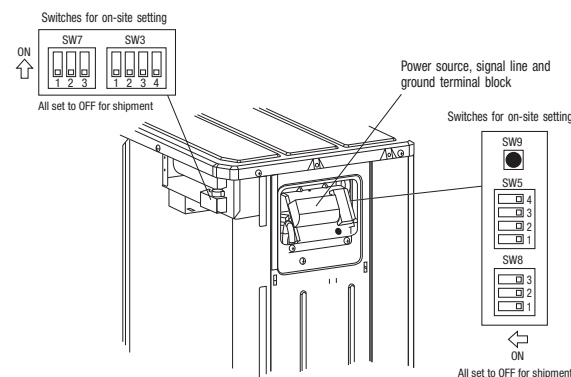

- ※1 Do not operate SW3-3, SW5-1, SW5-2, SW8.
- ※2 Refer to TECHNICAL MANUAL about SW9. (Pump down SW)

6. UTILIZATION OF EXISTING PIPING.

Check whether an existing pipe system is reusable or not by using the following flow chart.

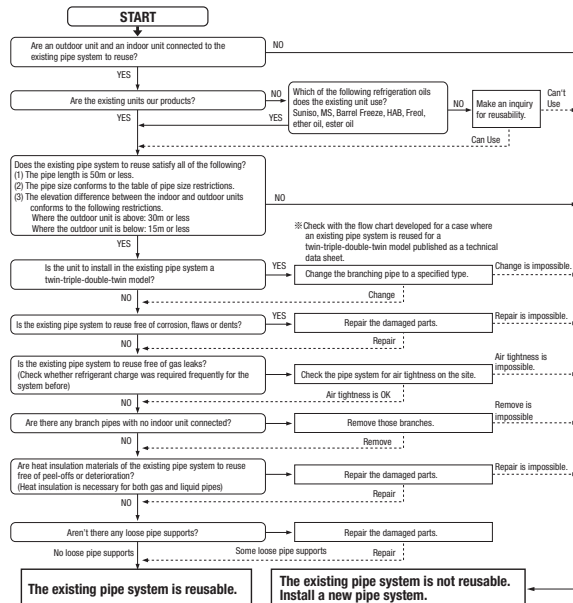

<Where the existing unit can be run for a cooling operation.>

Carry out the following steps with the existing unit (in the order of (1), (2), (3) and (4))

- (1) Run the unit for 30 minutes for a cooling operation.
- (2) Stop the indoor fan and run the unit for 3 minutes for a cooling operation (returning liquid)
- (3) Close the liquid side operation valve of the outdoor unit and pump down (refrigerant recovery)
- (4) Blow with nitrogen gas. ※ If discolored refrigeration oil or any foreign matters is discharged by the blow, wash the pipe system or install a new pipe system.
 - For the flare nut, do not use the old one, but use the one supplied with the outdoor unit. Process a flare to the dimensions specified for R410A.
 - Turn on-site setting switch SW8-1 to the ON position. (Where the gas pipe size is φ 19.05)

<Table of pipe size restrictions>

◎:Standard pipe size ○:Usable △:Restricted to shorter pipe length limits Cool ↓ : Cooling capacity drop

Additional charge volume per meter of pipe		0.06kg/m		0.08kg/m
Pipe size	Liquid pipe	φ9.52	φ9.52	φ12.7
	Gas pipe	φ12.7	φ15.88	φ15.88
71V	Usability	Cool ↓	◎	△
	Maximum one-way pipe length	35	50	25
	Length covered without additional charge	30	30	15

● The pipe length should be at least 5m. If the pipe length is shorter than 5m, the quantity of refrigerant needs reduced. Please consult with our distributor in the area, if you need to recover refrigerant and charge it again.

● Any combinations of pipe sizes not listed in the table are not usable.

<Pipe system after the branching pipe>

◎:Standard pipe size ○:Usable

Additional charging amount of refrigerant per 1m		0.06kg/m	
Pipe size	Liquid pipe	φ9.52	
	Gas pipe	φ12.7	φ15.88
Model	Combination type	Combination of capacity	
FDC71	Twin	40+40	
		◎	○

● Any combinations of pipe sizes not listed in the table are not usable.

<The model types of existing units of which branching pipes are reusable.>

The branching pipes used with models other than those listed above are not reusable.

Use our genuine branching pipes for R410A.

Formula to calculate additional charge volume

Additional charge volume (kg) = (Main pipe length (m) – Length covered without additional charge shown in the table) × Additional charge volume per meter of pipe shown in the table
+ (Total length of branch pipes (m) × Additional charge volume per meter of pipe shown in the table)

※ If you obtain a negative figure as a result of calculation, no additional refrigerant needs to be charged.

Example When an 71V (single installation) is installed in a 30m long existing pipe system (liquid φ 12.7, gas φ 15.88), the quantity of refrigerant to charge additionally should be (30m-15m) × 0.08kg/m = 1.2 kg.

Example When an 71V (twin installation) is installed in a 30m long existing pipe system (main pipe length 20m, liquid φ 12.7, gas φ 15.88; pipe length after branching pipe 5m x 2, liquid φ 9.52, gas φ 12.7) the quantity of refrigerant to charge additionally should be (20m-15m) × 0.08kg/m + 5m x 2 × 0.06kg/m = 1.0 kg.

<Where the existing unit cannot be run for a cooling operation.>

Wash the pipe system or install a new pipe system.

● If you choose to wash the pipe system, contact our distributor in the area.

PSB012D923D **(c) Models FDC100 ~ 140VN, 100 ~ 140VS**



Inverter driven single split PAC

100V · 125V · 140V

Designed for R410A refrigerant

- ⦿ This installation manual deals with outdoor units and general installation specifications only. For indoor units, refer to the respective installation manuals supplied with the units.
- ⦿ Read this manual carefully before you set to installation work and carry it out according to the instructions contained in this manual.

PRECAUTIONS FOR SAFETY

- When installing the equipment, carefully read the Precautions for safety and make sure that safety is maintained.
- The safety items contain important information regarding safety. Be sure to follow them. The symbols used and their meanings are as follows.
 -  **WARNING** : Improper installation could result in serious accident causing death or serious injury.
 -  **CAUTION** : Improper installation could result in serious accident.
- After installation, along with confirming that no abnormalities were seen from the operation test. Explain operating methods as well as maintenance methods to the user of this equipment, based on the owner's manual.
- For 3phase power source outdoor unit, EN61000-3-2 and EN60555-3 are not applicable as consent by the utility company or notification to the utility company is given before usage.
- 3phase power source unit, both indoor and outdoor, is suitable for installation in a commercial and light industrial environment. If installed as a house-hold appliance it could cause electromagnetic interference.
- 5 and 6 HP units of single phase power source are equipment complying with IEC 61000-3-12.
- Ask the customer to keep this manual together with the operation manual.

Check before installation work**[Accessory]**

Edging		1 piece	knock-out hole protection
--------	---	---------	---------------------------

- Model name and power source
- Refrigerant piping length
- Piping, wiring and miscellaneous small parts
- Indoor unit installation manual

**WARNING**

- Ask your dealer or a specialized service provider to install the unit. Improper installation work performed on the part of a user can result in water leaks, electric shocks and/or a fire.
- Carry out installation work properly in accordance with this installation manual. Improper installation work could result in water leaks, electric shocks, or a fire.
- When installing a unit in a small room, it is necessary to take appropriate precautions so that a refrigerant leak, if occurs, may not cause a buildup in excess of the concentration limit. For information on such precautions to prevent an excessive buildup, contact your dealer. If refrigerant leaks and builds up beyond the concentration limit, it can cause a lack-of-oxygen accident.
- Install the unit securely onto a structure that can withstand its weight with a good safety margin. Installation onto a structure that is not strong enough can cause an accident such as a fall or drop of the unit.
- Install the unit according to the installation instructions so that it can withstand strong winds, such as typhoons, and earthquakes. Improper installation work can cause an accident such as a fall of the unit.
- Electrical installation work must be performed by an electrical installation service provider qualified by a power provider of the country, and be executed according to the technical standards and other regulations applicable to electrical installation in the country.
- In wiring, ensure solid cable connection using the specified cables and fasten cables securely so that the terminal block may not be subject to external force working through cables. Improper connection or fastening can cause heat generation and a resultant fire.
- In wiring, arrange cables suitably so that they may be contained neatly in place and then attach a lid and/or a service panel securely. Improper installation can cause heat generation and a resultant fire.
- Prevent any substance other than the specified refrigerant (R410A) such as air from entering the refrigerant cycle in installing or moving the air conditioning system. Contamination by air or a foreign substance can cause an abnormal pressure buildup inside the refrigerant cycle and a resultant explosion and personal injury.
- Use only parts supplied with the unit and specified supply parts for installation. The use of parts other than those approved by the manufacturer may cause a fall of the unit, water leaks, a fire, electric shocks, refrigerant leaks, performance degradation or control failures.
- Do not lay drain piping into a sewer where a toxic gas such as sulfuric gas is generated. There is a danger that a toxic gas will flow back into the room.
- If refrigerant gas leaks during installation work, ventilate the room. Refrigerant gas, if it comes into contact with bare fire, can cause the generation of a toxic gas.
- When installation work is completed, check the system for refrigerant gas leaks. If refrigerant gas leaks indoors and comes into contact with bare fire such as that of a fan heater, stove or cooking stove, it can cause the generation of a toxic gas.
- Sling the unit at the specified points with ropes properly rated for its weight in hoisting it for haulage. An improper hauling method can cause a fall of the unit resulting in death or serious personal injury.
- Always turn off power before you work inside the unit such as for installation or servicing. A failure to observe this instruction can cause a danger of receiving electric shocks.
- Do not open the operation valves (both liquid and gas valves) until refrigerant piping work, an air-tightness test and an air purge are completed. When refrigerant gas leaks during piping work, stop brazing pipes and ventilate the room. Refrigerant gas, when it comes into contact with bare fire, can cause the generation of a toxic gas.

**CAUTION**

- Ground the unit. Do not connect the ground wire to gas piping, water piping, a lightning rod, or telephone ground wires. Improper grounding can result in electric shocks or fire when any trouble or earth leakage occurs. 
- Be sure to install an earth leakage breaker. A failure to install an earth leakage breaker may result in the outbreak of fire or electric shocks.
- Do not install the unit in an area where a danger of flammable gas leaks exists. If a flammable gas does leak and build up around the unit, it can cause a fire.
- Install drain piping in accordance with the installation manual to ensure proper drainage and keep its temperature to prevent dew condensation. Improper piping work can cause water leaks and a soaking of household effects.
- Do not install the outdoor unit where winds from its fan blow directly onto a plant, etc. Winds can affect adversely to the plant, etc.
- Secure a space for inspection and maintenance as specified in the manual. An insufficient space can result in an accident such as a fall from the installation point and a resultant personal injury.
- When the outdoor unit is installed on a roof top or at an elevated point, provide permanent ladders and handrails along the access route and fences and handrails around the outdoor unit.
- In tightening a flare nut, use double spanners and observe the specified tightening torque. Care must be taken so as not to over-tighten a nut and damage the flare part. (Refer to the tightening torque) A loose or damaged flare part can cause a refrigerant gas leak and a resultant lack-of-oxygen accident.
- Dress the refrigerant piping with a heat insulation material for prevention of dew condensation. Improper heat insulation to prevent dew condensation can cause leaking or dripping water and a resultant soaking of household effects.
- When refrigerant piping work is completed, check it for air tightness with nitrogen gas and make sure that it does not have any leak. A refrigerant gas leak in a narrow room beyond the concentration limit can cause a lack-of-oxygen accident.

Notabilia as a unit designed for R410A

- Do not use any refrigerant other than R410A. R410A will rise to pressure about 1.6 times higher than that of a conventional refrigerant. A cylinder containing R410A has a pink indication mark on the top.
- A unit designed for R410A has adopted a different size indoor unit operation valve charge port and a different size check joint provided in the unit to prevent the charging of a wrong refrigerant by mistake. The processed dimension of the flared part of a refrigerant pipe and a flare nut's parallel side measurement have also been altered to raise strength against pressure. Accordingly, you are required to arrange dedicated R410A tools listed in the table on the right before installing or servicing this unit.
- Do not use a charge cylinder. The use of a charge cylinder will cause the refrigerant composition to change, which results in performance degradation.
- In charging refrigerant, always take it out from a cylinder in the liquid phase.
- All indoor units must be models designed exclusively for R410A. Check connectable indoor unit models in a catalog, etc. (A wrong indoor unit, if connected into the system, will impair proper system operation)

	Dedicated R410A tools
a)	Gauge manifold
b)	Charge hose
c)	Electronic scale for refrigerant charging
d)	Torque wrench
e)	Flare tool
f)	Protrusion control copper pipe
g)	Vacuum pump adapter
h)	Gas leak detector

1. HAULAGE AND INSTALLATION (Take particular care in carrying in or moving the unit, and always perform such an operation with two or more persons.)

CAUTION When a unit is hoisted with slings for haulage, take into consideration the offset of its gravity center position. If not properly balanced, the unit can be thrown off-balance and fall.

1) Delivery

- Deliver the unit as close as possible to the installation site before removing it from the packaging.
- When some compelling reason necessitates the unpacking of the unit before it is carried in, use nylon slings or protective wood pieces so as not to damage the unit by ropes lifting it.

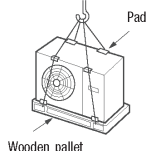

2) Portage

- The right hand side of the unit as viewed from the front (diffuser side) is heavier. A person carrying the right hand side must take heed of this fact. A person carrying the left hand side must hold with his right hand the handle provided on the front panel of the unit and with his left hand the corner column section.

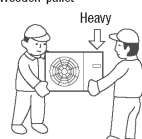

3) Selection of installation location for the outdoor unit

Be sure to select a suitable installation place in consideration of following conditions.

- A place where it is horizontal, stable and can endure the unit weight and will not allow vibration transmittance of the unit.
- A place where it can be free from possibility of bothering neighbors due to noise or exhaust air from the unit
- A place where the unit is not exposed to oil splashes.
- A place where it can be free from danger of flammable gas leakage.
- A place where drain water can be disposed without any trouble.
- A place where the unit will not be affected by heat radiation from other heat source.
- A place where snow will not accumulate.
- A place where the unit can be kept away 5m or more from TV set and/or radio receiver in order to avoid any radio or TV interference.
- A place where good air circulation can be secured, and enough service space can be secured for maintenance and service of the unit safely.
- A place where the unit will not be affected by electromagnetic waves and/or high-harmonic waves generated by other equipment.
- A place where chemical substances like sulfuric gas, chloric gas, acid and alkali (including ammonia), which can harm the unit, will not be generated and not remain.
- A place where strong wind will not blow against the outlet air blow of the unit.

4) Caution about selection of installation location

(1) If the unit is installed in the area where the snow will accumulate, following measures are required. The bottom plate of unit and intake, outlet may be blocked by snow.

1. Install the unit on the base so that the bottom is higher than snow cover surface.

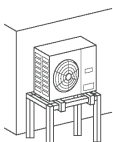

2. Provide a snow hood to the outdoor unit on site. Regarding outline of a snow hood, refer to our technical manual.



3. Install the unit under eaves or provide the roof on site.

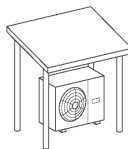

Since drain water generated by defrost control may freeze, following measures are required.

- Don't execute drain piping work by using a drain elbow and drain grommets (optional parts). [Refer to Drain piping work.]
- Recommend setting Defrost Control (SW3-1) and Snow Guard Fan Control (SW3-2). [Refer to Setting SW3-1, SW3-2.]

(2) If the unit can be affected by strong wind, following measures are required. Strong wind can cause damage of fan (fan motor), or can cause performance degradation, or can trigger the unit to stop due to rising of high pressure.

1. Install the outlet air blow side of the unit to face a wall of building, or provide a fence or a windbreak screen.
2. Install the outlet air blow side of the unit in a position perpendicular to the direction of wind.
3. The unit should be installed on the stable air foundation. If the foundation level, tie down the wires.

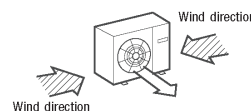
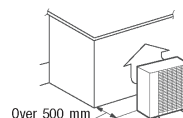

5) Installation space

- Walls surrounding the unit in the four sides are not acceptable.
- There must be a 1-meter or larger space in the above.
- Where a danger of short-circuiting exists, install guide louvers.
- When more than one unit are installed, provide sufficient intake space consciously so that short-circuiting does not occur.
- Where piling snow can bury the outdoor unit, provide proper snow guards.
- A barrier wall placed in front of the exhaust diffuser must not be higher than the unit.

Size	100V~140V (mm)		
	I	II	III
L1	Open	Open	500
L2	300	5	Open
L3	150	300	150
L4	5	5	5

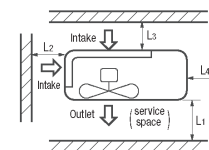

6) Installation

① Anchor bolt fixed position

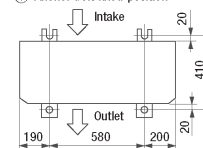

② Notabilia for installation

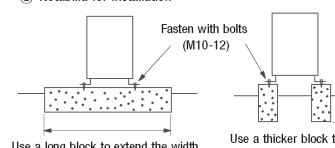

- In installing the unit, fix the unit's legs with bolts specified on the left.
- The protrusion of an anchor bolt on the front side must be kept within 15 mm.
- Securely install the unit so that it does not fall over during earthquakes or strong winds, etc.
- Refer to the left illustrations for information regarding concrete foundations.
- Install the unit in a level area. (With a gradient of 5 mm or less.)
- Improper installation can result in a compressor failure, broken piping within the unit and abnormal operation.

7) To run the unit for a cooling operation, when the outdoor temperature is -5°C or lower.

- When the outdoor air temperature is -5°C or lower, provide a snow hood to the outdoor unit so that strong wind will not blow against the outdoor heat exchanger directly. Regarding outline of a snow hood, refer to our technical manual.

2. REFRIGERANT PIPING WORK

1) Restrictions on unit installation and use

- Check the following points in light of the indoor unit specifications and the installation site.
- Observe the following restrictions on unit installation and use. Improper installation can result in a compressor failure or performance degradation.

Descriptions	One-way pipe length difference from the first branching point to the indoor unit				Marks appearing in the drawing	
	Model for outdoor units	Dimensional limitations	Single type	Twin type	< 3m	≥ 3m
One-way pipe length of refrigerant piping	100V,125V	≦ 50m	L	L+L1+L2	—	—
	140V				L+L1+L2+L3	L+La+L1+L2+L3
Main pipe length	100V,125V	≦ 50m	—	L	—	—
	140V		—	—	L	L
One-way pipe length between the first branching point from to the second branching point	140V	≦ 5m	—	—	—	La
One-way pipe length after the first branching point	100V,125V	≦ 30m	—	L1, L2	—	—
	140V		—	—	L1, L2, L3	L1 (1)
One-way pipe length after the first branching point and second branching point	140V	≦ 27m	—	—	—	La+L2, La+L3 (1)
One-way pipe length difference from the first branching point to the indoor unit	Twin type	≦ 10m	—	—	—	—
	Triple type	≦ 3m	—	L1-L2	L1-L2 , L2-L3 , L3-L1	—
One-way pipe length difference from the second branching point to the indoor unit	140V	≦ 10m	—	—	—	L2-L3
	140V	≦ 10m	—	—	—	L-(La+L2), L1-(La+L3) (1)
Elevation difference between indoor and outdoor units	When the outdoor unit is positioned higher,	≦ 30m	H	H	H	H
	When the outdoor unit is positioned lower,	≦ 15m	H	H	H	H
Elevation difference between indoor units	≦ 0.5m	—	—	h	h1, h2, h3	h1, h2, h3

CAUTION

- The use restrictions appearing in the table above are applicable to the standard pipe size combinations shown in the table below. Where an existing pipe system is utilized, different one-way pipe length restrictions should apply depending on its pipe size. For more information, see "6. UTILIZATION OF EXISTING PIPING."
- With the triple pipe connection, the way of use is different when the difference of one-way pipe length after the first branching point is 3m to 10m. For details, refer to the above table and right figure.

Note (1) Install the indoor units so that L + L1 becomes the longest one-way pipe.
Keep the pipe length difference between L1 and (La + L2) or (La + L3) within 10m.

2) Determination of pipe size

- Determine refrigerant pipe size pursuant to the following guidelines based on the indoor unit specifications.

Outdoor unit connected	Model 100V		Model 125V				Model 140V	
	Gas pipe	Liquid pipe	Gas pipe	Liquid pipe	Gas pipe	Liquid pipe	Gas pipe	Liquid pipe
Refrigerant piping (branch pipe)	φ15.88	φ9.52	φ15.88	φ9.52	φ15.88	φ9.52	φ15.88	φ9.52
In the case of a single type	Flare	Flare	Flare	Flare	Flare	Flare	Flare	Flare
	Indoor unit connected	φ15.88	φ9.52	φ15.88	φ9.52	φ15.88	φ9.52	φ15.88
Capacity of indoor unit	Model 100V, Model VA40		Model 125V, Model VA50		Model 140V, Model VA60		Model 140V, Model VA60	
	DIS-WA1		DIS-WA1		DIS-WA1		DIS-WA1	
In the case of a twin type	Refrigerant piping (branch pipe L1,L2)	φ12.7	φ9.52	φ12.7	φ9.52	φ15.88	φ9.52	φ15.88
	Indoor unit connected	φ12.7	φ6.35	φ12.7	φ6.35	φ15.88	φ6.35	φ15.88
Capacity of indoor unit	Model 50V×2, Model VA20×2		Model 60V×2		Model VA25×2		Model 71V×2, Model 30V×2	
	DIS-TA1		DIS-TA1		DIS-TA1		DIS-TA1	
In the case of a triple type A	Refrigerant piping (branch pipe L1,L2,L3)	—	—	—	—	—	—	—
	Indoor unit connected	—	—	—	—	—	—	—
Capacity of indoor unit	Model 50V×3, Model VA20×3		Model 60V×3		Model VA25×3		Model 71V×3, Model 30V×3	
	DIS-WA1		DIS-WA1		DIS-WA1		DIS-WA1	
In the case of a triple type B	Refrigerant piping (branch pipe La)	—	—	—	—	—	—	—
	Refrigerant piping (branch pipe L1)	—	—	—	—	—	—	—
Indoor unit connected	φ15.88	φ9.52	φ12.7	φ9.52	φ12.7	φ9.52	φ12.7	φ9.52
	φ12.7	φ9.52	φ12.7	φ9.52	φ12.7	φ9.52	φ12.7	φ9.52
Capacity of indoor unit	Model 50V×3, Model VA20×3		Model 60V×3		Model VA25×3		Model 71V×3, Model 30V×3	
	DIS-WA1		DIS-WA1		DIS-WA1		DIS-WA1	

CAUTION

- When the 50V or 60V model is connected as an indoor unit, always use a φ9.52 liquid pipe for the branch (branching pipe – indoor unit) and a different diameter joint supplied with the branching pipe set for connection with the indoor unit (φ6.35 on the liquid pipe side). If a φ6.35 pipe is used for connection with a branching pipe, a refrigerant distribution disorder may occur, causing one of the indoor units to fall short of the rated capacity.
- A riser pipe must be a part of the main. A branching pipe set should be installed horizontally at a point as close to an indoor unit as possible. A branching part must be dressed with a heat-insulation material supplied as an accessory.
- For the details of installation work required at and near a branching area, see the installation manual supplied with your branching pipe set.

< Single type >

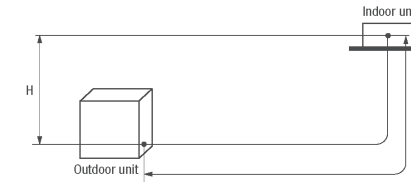

< Twin type >

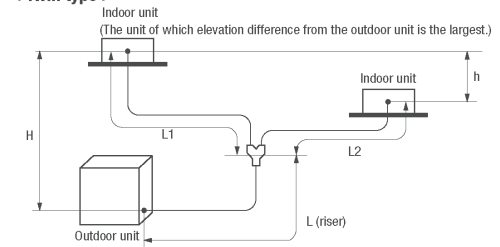

< Triple type >

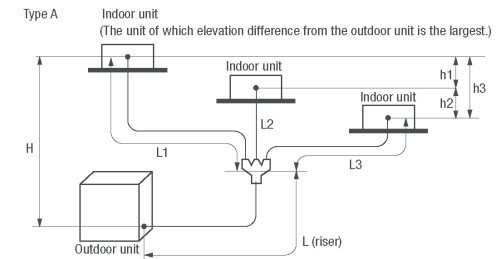

< Triple type >

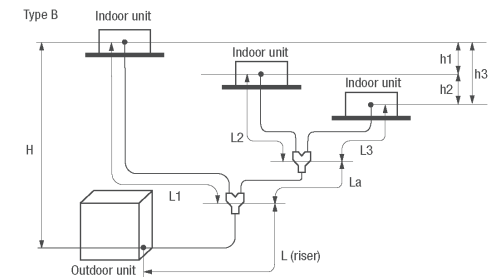

About brazing

Brazing must be performed under a nitrogen gas flow.

Without nitrogen gas, a large quantity of foreign matters (oxidized film) are created, causing a critical failure from capillary tube or expansion valve clogging.

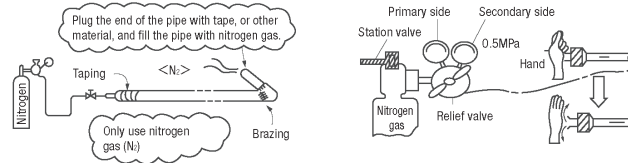

3) Refrigerant pipe wall thickness and material

- Select refrigerant pipes of the table shown on the right wall thickness and material as specified for each pipe size.
- This unit uses R410A. Always use 1/2H pipes having a 1.0mm or thicker wall for $\phi 19.05$ or larger pipes, because O-type pipes do not meet the pressure resistance requirement.

Pipe diameter [mm]	6.35	9.52	12.7	15.88	22.22	25.4	28.58
Minimum pipe wall thickness [mm]	0.8	0.8	0.8	1.0	1.0	1.0	1.0
Pipe material*	O-type pipe	O-type pipe	O-type pipe	O-type pipe	1/2H-type pipe	1/2H-type pipe	1/2H-type pipe

*Phosphorus deoxidized seamless copper pipe C1220T, JIS H3300

NOTE

- Select pipes having a wall thickness larger than the specified minimum wall thickness.

4) On-site piping work

IMPORTANT

- Take care so that installed pipes may not touch components within a unit. If touching with an internal component, it will generate abnormal sounds and/or vibrations.

How to remove the service panel

First remove the five screws (X mark) of the service panel and push it down into the direction of the arrow mark and then remove it by pulling it toward you.

- The pipe can be laid in any of the following directions: side right, front, rear and downward.
- Remove a knock-out plate provided on the pipe penetration to open a minimum necessary area and attach an edging material supplied as an accessory by cutting it to an appropriate length before laying a pipe.
- Carry out the on site piping work with the operation valve fully closed.
- Give sufficient protection to a pipe end (compressed and blazed, or with an adhesive tape) so that water or foreign matters may not enter the piping.
- Bend a pipe to a radius as large as practical.(R100~R150). Do not bend a pipe repeatedly to correct its form.
- Flare connection is used between the unit and refrigerant pipe. Flare a pipe after engaging a flare nut onto it. Flare dimensions for R410A are different from those for conventional R407C. Although we recommend the use of flaring tools designed specifically for R410A, conventional flaring tools can also be used by adjusting the measurement of protrusion B with a protrusion control gauge.

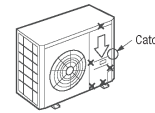

Flared pipe end: A (mm)	
Copper pipe outer diameter	A
$\phi 6.35$	9.1
$\phi 9.52$	13.2
$\phi 12.7$	16.6
$\phi 15.88$	19.7

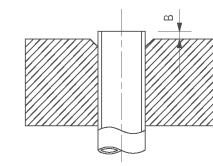
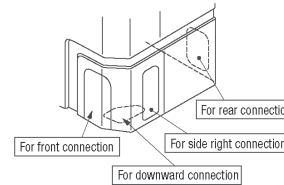

Copper pipe outer diameter	Copper pipe protrusion for flaring: B (mm)	
	In the case of a rigid pipe	In the case of a rigid pipe
$\phi 6.35$	0~0.5	
$\phi 9.52$	0~0.5	
$\phi 12.7$	0~0.5	
$\phi 15.88$	0~0.5	

- Tighten a flare joint securely with a double spanner.

CAUTION

Do not apply force beyond proper fastening torque in tightening the flare nut.

Fix both liquid and gas service valves at the valve main bodies as illustrated on the right, and then fasten them, applying appropriate fastening torque.

Operation valve size (mm)	Tightening torque (N-m)	Tightening angle (°)	Recommended length of a tool handle (mm)
$\phi 6.35$ (1/4")	14~18	45~60	150
$\phi 9.52$ (3/8")	34~42	30~45	200
$\phi 12.7$ (1/2")	49~61	30~45	250
$\phi 15.88$ (5/8")	68~82	15~20	300

Do not hold the valve cap area with a spanner.

Use a torque wrench. If a torque wrench is not available, fasten the flare nut manually first and then tighten it further, using the left table as a guide.

5) Air tightness test

- Although outdoor and indoor units themselves have been tested for air tightness at the factory, check the connecting pipes after the installation work for air tightness from the operation valve's check joint equipped on the outdoor unit side. While conducting a test, keep the operation valve shut all the time.
 - Raise the pressure to 0.5 MPa, and then stop. Leave it for five minutes to see if the pressure drops.
 - Then raise the pressure to 1.5 MPa, and stop. Leave it for five more minutes to see if the pressure drops.
 - Then raise the pressure to the specified level (4.15 MPa), and record the ambient temperature and the pressure.
 - If no pressure drop is observed with an installation pressurized to the specified level and left for about one day, it is acceptable. When the ambient Temperature fall 1°C, the pressure also fall approximately 0.01 MPa. The pressure, if changed, should be compensated for.
 - If a pressure drop is observed in checking e) and a) – d), a leak exists somewhere. Find a leak by applying bubble test liquid to welded parts and flare joints and repair it. After repair, conduct an air-tightness test again.
- In conducting an air-tightness test, use nitrogen gas and pressurize the system with nitrogen gas from the gas side. Do not use a medium other than nitrogen gas under any circumstances.

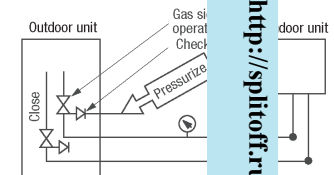

6) Evacuation

<Work flow> When the system has remaining moisture inside or a leaky point, the vacuum gauge indicator will rise. Check the system for a leaky point and then draw air to create a vacuum again.

Run the vacuum pump for at least one hour after the vacuum gauge shows -101kPa or lower. (-755mmHg or lower)
Confirm that the vacuum gauge indicator does not rise even if the system is left for one hour or more.

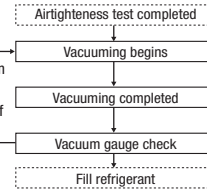

Pay attention to the following points in addition to the above for the R410A and compatible machines.

- To prevent a different oil from entering, assign dedicated tools, etc. to each refrigerant type. Under no circumstances must a gauge manifold and a charge hose in particular be shared with other refrigerant types (R22, R407C, etc.).
- Use a counterflow prevention adapter to prevent vacuum pump oil from entering the refrigerant system.

7) Additional refrigerant charge

(1) Calculate a required refrigerant charge volume from the following table.

<Single type>

Item Capacity	Standard refrigerant charge volume (kg)	Pipe length for standard refrigerant charge volume (m)	Additional charge volume (kg) per meter of refrigerant piping (liquid pipe)	Refrigerant volume charged for shipment at the factory (kg)	Installation's pipe length (m) covered without additional refrigerant charge
Model 100V	2.0	0	0.06	3.8	30
Model 125V					
Model 140V					

<Twin, triple, W-twin type>

Item Capacity	Standard refrigerant charge volume (kg)	Pipe length for standard refrigerant charge volume (m)	Additional charge volume (kg) per meter of refrigerant piping (liquid pipe)		Refrigerant volume charged for shipment at the factory (kg)	Installation's pipe length (m) covered without additional refrigerant charge
			Main pipe	Branch pipe		
Model 100V	2.0	0	0.06		3.8	30
Model 125V						
Model 140V						

- A standard refrigerant charge volume means a refrigerant charge volume for an installation with 0m long refrigerant piping.
- This unit contains factory charged refrigerant covering 30m of refrigerant piping and additional refrigerant charge on the installation site is not required for an installation with up to 30m refrigerant piping. When refrigerant piping exceeds 30m, additionally charge an amount calculated from the pipe length and the above table for the portion in excess of 30m.
- When refrigerant piping is shorter than 3m, reduce refrigerant by 1kg from the factory charged volume and adjust to 2.8kg.
- If an existing pipe system is used, a required refrigerant charge volume will vary depending on the liquid pipe size. For further information, see "6. UTILIZATION OF EXISTING PIPING."

Formula to calculate the volume of additional refrigerant required

Model 100~140V	Additional charge volume (kg) = { Main pipe length (m) - Length covered without additional charge 30 (m) } x 0.06 (kg/m) + Total length of branch pipes (m) x 0.06 (kg/m)
----------------	---

*When an additional charge volume calculation result is negative, it is not necessary to charge refrigerant additionally.

- To charge refrigerant again, recover refrigerant from the system first and then charge the volume calculated from the above table (Standard refrigerant charge volume + branch pipes charge volume)

(2) Charging refrigerant

- Since R410A refrigerant must be charged in the liquid phase, you should charge it, keeping the container cylinder upside down or using a refrigerant cylinder equipped with a siphon tube.
- Charge refrigerant always from the liquid side service port with the operation valve shut. When you find it difficult to charge a required amount, fully open the outdoor unit valves on both liquid and gas sides and charge refrigerant from the gas (suction) side service port, while running the unit in the cooling mode. In doing so, care must be taken so that refrigerant may be discharged from the cylinder in the liquid phase all the time. When the cylinder valve is throttled down or a dedicated conversion tool to change liquid-phase refrigerant into mist is used to protect the compressor, however, adjust charge conditions so that refrigerant will gasify upon entering the unit.
- In charging refrigerant, always charge a calculated volume by using a scale to measure the charge volume.
- When refrigerant is charged with the unit being run, complete a charge operation within 30 minutes. Running the unit with an insufficient quantity of refrigerant for a long time can cause a compressor failure.

NOTE Put down the refrigerant volume calculated from the pipe length onto the caution label attached on the back side of the service panel.

8) Heating and condensation prevention

- (1) Dress refrigerant pipes (both gas and liquid pipes) for heat insulation and prevention of dew condensation.
- (2) Use a heat insulating material that can withstand 120°C or a higher temperature. Poor heat insulating capacity can cause heat insulation problems or cable deterioration.
 - Improper heat insulation/anti-dew dressing can result in a water leak or dripping causing damage to household effects, etc.
 - All gas pipes must be securely heat insulated in order to prevent damage from dripping water that comes from the condensation formed on them during a cooling operation or personal injury from burns because their surface can reach quite a high temperature due to discharged gas flowing inside during a heating operation.
 - Wrap indoor units' flare joints with heat insulating parts (pipe cover) for heat insulation (both gas and liquid pipes).
 - Give heat insulation to both gas and liquid side pipes. Bundle a heat insulating material and a pipe tightly together so that no gaps may be left between them and wrap them together with a connecting cable by a dressing tape.
 - Although it is verified in a test that this air conditioning unit shows satisfactory performance under JIS condensation test conditions, **both gas and liquid pipes need to be dressed with 20 mm or thicker heat insulation materials above the ceiling where relative humidity exceeds 70%.**

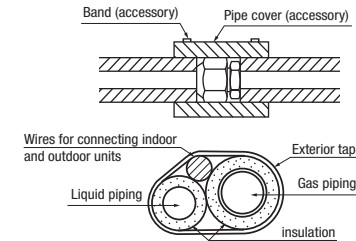

3. DRAIN PIPING WORK

- Execute drain piping by using a drain elbow and drain grommets supplied separately as optional parts, where water drained from the outdoor unit is a problem.

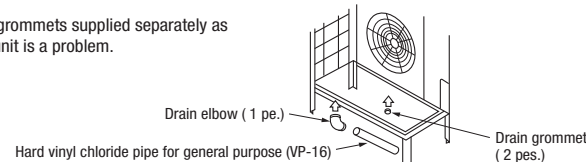

- There are 3 drain holes provided on the bottom plate of an outdoor unit to discharge condensed water.
- When condensed water needs to be led to a drain, etc., install the unit on a flat base (supplied separately as an optional part) or concrete blocks.
- Connect a drain elbow as shown in the illustration and close the other two drain holes with grommets.

4. ELECTRICAL WIRING WORK For details of electrical cabling, refer to the indoor unit installation manual.

Electrical installation work must be performed by an electrical installation service provider qualified by a power provider of the country. Electrical installation work must be executed according to the technical standards and other regulations applicable to electrical installations in the country.

- Do not use any supply cord lighter than one specified in parentheses for each type below.
 - braided cord (code designation 60245 IEC 51),
 - ordinary tough rubber sheathed cord (code designation 60245 IEC 53)
 - flat twin tinsel cord (code designation 60227 IEC 41);
- Do not use anything lighter than polychloroprene sheathed flexible cord (code designation 60245 IEC57) for supply cords of parts of appliances for outdoor use.
- Ground the unit. Do not connect the grounding wire to a gas pipe, water pipe, lightning rod or telephone grounding wire. If improperly grounded, an electric shock or malfunction may result.
- A grounding wire must be connected before connecting the power cable. Provide a grounding wire longer than the power cable.
- The installation of an impulse withstanding type earth leakage breaker is necessary. A failure to install an earth leakage breaker can result in an accident such as an electric shock or a fire.
- Do not turn on the power until the electrical work is completed.
- Do not use a condensive capacitor for power factor improvement under any circumstances. (It does not improve power factor, while it can cause an abnormal overheat accident)
- For power supply cables, use conduits.
- Do not lay electronic control cables (remote control and signaling wires) and other cables together outside the unit. Laying them together can result in the malfunctioning or a failure of the unit due to electric noises.
- Fasten cables so that they may not touch the piping, etc.
- When cables are connected, make sure that all electrical components within the electrical component box are free of loose connector coupling or terminal connection and then attach the cover securely. (Improper cover attachment can result in malfunctioning or a failure of the unit, if water penetrates into the box.)
- Always use a three-core cable for an indoor-outdoor connecting cable. Never use a shield cable.

- Connect a pair bearing a common terminal number with an indoor-outdoor connecting wire.
- In cabling, fasten cables securely with cable clamps so that no external force may work on terminal connections.
- Grounding terminals are provided in the control box.

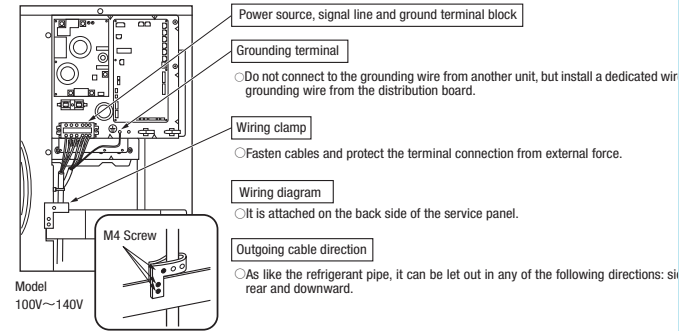

Power cable, indoor-outdoor connecting wires

- Always perform grounding system installation work with the power cord unplugged.



CAUTION Always use an earth leakage circuit breaker designed for inverter circuits to prevent a faulty operation.

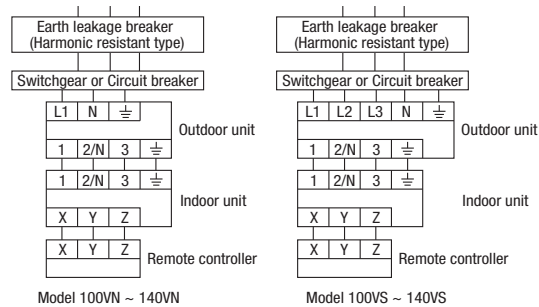

Model	Power source	Power cable thickness(mm ²)	MAX. over current (A)	Cable length (m)	Grounding wire thickness	Indoor-outdoor wire thickness
100VN	Single phase 3 wire 220-240V 50Hz 220V 60Hz	5.5	24	25	φ1.6mm	φ1.6mm x 3
125VN						
140VN						
100VS	3 phase 4 wire 380-415V 50Hz 380V 60Hz	3.5	15	27	φ1.6mm	φ1.6mm x 3
125VS						
140VS						

※At the connection with the duct type indoor unit.

Model	Power source	Power cable thickness(mm ²)	MAX. over current (A)	Cable length (m)	Grounding wire thickness	Indoor-outdoor wire thickness
100VN	Single phase 3 wire 220-240V 50Hz 220V 60Hz	5.5	25	24	φ1.6mm	φ1.6mm x 3
125VN			27	22		
140VN			28	32		
100VS	3 phase 4 wire 380-415V 50Hz 380V 60Hz	3.5	16	26	φ1.6mm	φ1.6mm x 3
125VS			18	23		
140VS			19	21		

- The specifications shown in the above table are for units without heaters. For units with heaters, refer to the installation instructions or the instructions of the indoor unit.
- Switchgear or Circuit breaker capacity which is calculated from MAX. over current should be chosen along the regulations in each country.
- The cable specifications are based on the assumption that a metal or plastic conduit is used with no more than three cables contained in a conduit and the drop is 2%. For an installation falling outside of these conditions, follow the internal cabling regulations. Adapt it to the regulation in effect in each country.

5. TEST RUN

⚠ WARNING

- Before conduct a test run, do not fail to make sure that the operation valves are closed.
- Turn on power 6 hours prior to a test run to energize the crank case heater.
- In case of the first operation after turning on power, even if the unit does not move for 30 minutes, it is not a breakdown.
- Always give a 3-minute or longer interval before you start the unit again whenever it is stopped.
- Removing the service panel will expose high-voltage live parts and high-temperature parts, which are quite dangerous.
- Take utmost care not to incur an electric shock or burns. Do not leave the unit with the service panel open.

⚠ CAUTION

- When you operate switches (SW3, SW5) for on-site setting, be careful not to touch a live part.
- You cannot check discharge pressure from the liquid operation valve charge port.
- The 4-way valve (20S) is energized during a heating operation.
- When power supply is cut off to reset the unit, give 3 or more minutes before you turn on power again after power is cut off. If this procedure is not observed in turning on power again, "Communication error between outdoor and indoor unit" may occur.

A failure to observe these instructions can result in a compressor breakdown.

1) Test run method

- (1) A test run can be initiated from an outdoor unit by using SW3-3 and SW3-4 for on-site setting.
- (2) Switching SW3-3 to ON will start the compressor.
- (3) The unit will start a cooling operation, when SW3-4 is OFF, or a heating operation, when SW3-4 is ON.
- (4) **Do not fail to switch SW3-3 to OFF when a test run is completed.**

SW-3-3	SW-3-4	
ON	OFF	Cooling during a test run
	ON	Heating during a test run
OFF	—	Normal or After the test operation

2) Checking the state of the unit in operation

Use check joints provided on the piping before and after the four-way valve installed inside the outdoor unit for checking discharge pressure and suction pressure. As indicated in the table shown on the right, pressure detected at each point will vary depending on whether a cooling or heating operation has been selected.

	Check joint of the pipe	Charge port of the gas operation valve
Cooling operation	Discharge pressure (High pressure)	Suction pressure (Low pressure)
Heating operation	Suction pressure (Low pressure)	Discharge pressure (High pressure)

3) Setting SW3-1, SW3-2, on-site

- (1) Defrost control switching (SW3-1)
 - When this switch is turned ON, the unit will run in the defrost mode more frequently.
 - Set this switch to ON, when installed in a region where outdoor temperature falls below zero during the season the unit is run for a heating operation.
- (2) Snow guard fan control (SW3-2)
 - When this switch is turned on, the outdoor unit fan will run for 10 seconds in every 10 minutes, when outdoor temperature falls to 3°C or lower and the compressor is not running.
 - When the unit is used in a very snowy country, set this switch to ON.

4) Failure diagnosis in a test run

Error indicated on the remote control unit	Printed circuit board LED(The cycles of 5 seconds)		Failure event	Action
	Red LED	Green LED		
E34	Blinking once	Blinking continuously	Open phase	Check power cables for loose contact or disconnection
E40	Blinking once	Blinking continuously	63H1 actuation or operation with operation valves shut (occurs mainly during a heating operation)	1. Check whether the operation valves are open. 2. If an error has been canceled when 3 minutes have elapsed since a compressor stop, you can restart the unit by effecting Check Reset from the remote control unit.
E49	Blinking once	Blinking continuously	Low pressure error or operation with operation valves shut (occurs mainly during a cooling operation)	

- If an error code other than those listed above is indicated, refer to the wiring diagram of the outdoor unit and the indoor unit.

5) The state of the electronic expansion valve.

The following table illustrates the steady states of the electronic expansion valve.

	When power is turned on	When the unit comes to a normal stop		When the unit comes to an abnormal stop	
		During a cooling operation	During a heating operation	During a cooling operation	During a heating operation
Valve for a cooling operation	Complete shut position	Complete shut position	Full open position	Full open position	Full open position
Valve for a heating operation	Full open position	Full open position	Complete shut position	Full open position	Full open position

6) Heed the following on the first operation after turning on the circuit breaker.

This outdoor unit may start in the standby mode (waiting for a compressor startup), which can continue up to 30 minutes, to prevent the oil level in the compressor from lowering on the first operation after turning on the circuit breaker. If that is the case, do not suspect a unit failure.

Items to check before a test run

- When you leave the outdoor unit with power supplied to it, be sure to close the panel.

Item No. used in the installation manual	Item	Check item	Check
2	Refrigerant plumbing	If brazed, was it brazed under a nitrogen gas flow?	
		Were air-tightness test and vacuum extraction surely performed?	
		Are heat insulation materials installed on both liquid and gas pipes?	
		Are operation valves surely opened for both liquid and gas systems?	
		Have you recorded the additional refrigerant charge volume and refrigerant pipe length on the panel's label?	
4	Electric wiring	Is the unit free of cabling errors such as uncompleted connection, an absent or reversed phase?	
		Are properly rated electrical equipments used for circuit breakers and cables?	
		Doesn't cabling cross-connect between units, where more than one unit are installed?	
		Aren't indoor-outdoor signal wires connected to remote control wires?	
		Do indoor-outdoor connecting cables connect between the same terminal numbers?	
		Are either VCT cabtype cables or WF flat cables used for indoor-outdoor connecting cables?	
		Does grounding satisfy the D type grounding (type III grounding) requirements?	
		Is the unit grounded with a dedicated grounding wire not connected to another unit's grounding wire?	
		Are cables free of loose screws at their connection points?	
		Are cables held down with cable clamps so that no external force works onto terminal connections?	
—	Indoor unit	Is indoor unit installation work completed?	
		Where a face cover should be attached onto an indoor unit, is the face cover attached to the indoor unit?	

Test run procedure

- Always carry out a test run and check the following in order as listed.

Turn	The contents of operation	Check
①	Open the gas side operation valve fully.	
②	Open the liquid side operation valve fully.	
③	Close the panel.	
④	Where a remote control unit is used for unit setup on the installation site, follow instructions for unit setup on the installation site with a remote control unit.	
⑤	SW3-3 ON / SW3-4 OFF: the unit will start a cooling operation. SW3-3 ON / SW3-4 ON: the unit will start a heating operation.	
⑥	When the unit starts operation, press the wind direction button provided on the remote control unit to check its operation.	
⑦	Place your hand before the indoor unit's diffuser to check whether cold (warm) winds come out in a cooling (heating) operation.	
⑧	Make sure that a red LED is not blinking.	
⑨	When you complete the test run, do not forget to turn SW3-3 to the OFF position.	
⑩	Where options are used, check their operation according to the respective instruction manuals.	

SWITCHES FOR ON-SITE SETTING SW5



All set to OFF for shipment

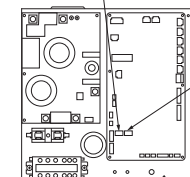

SWITCHES FOR ON-SITE SETTING SW3



All set to OFF for shipment

6. UTILIZATION OF EXISTING PIPING.

Check whether an existing pipe system is reusable or not by using the following flow chart.

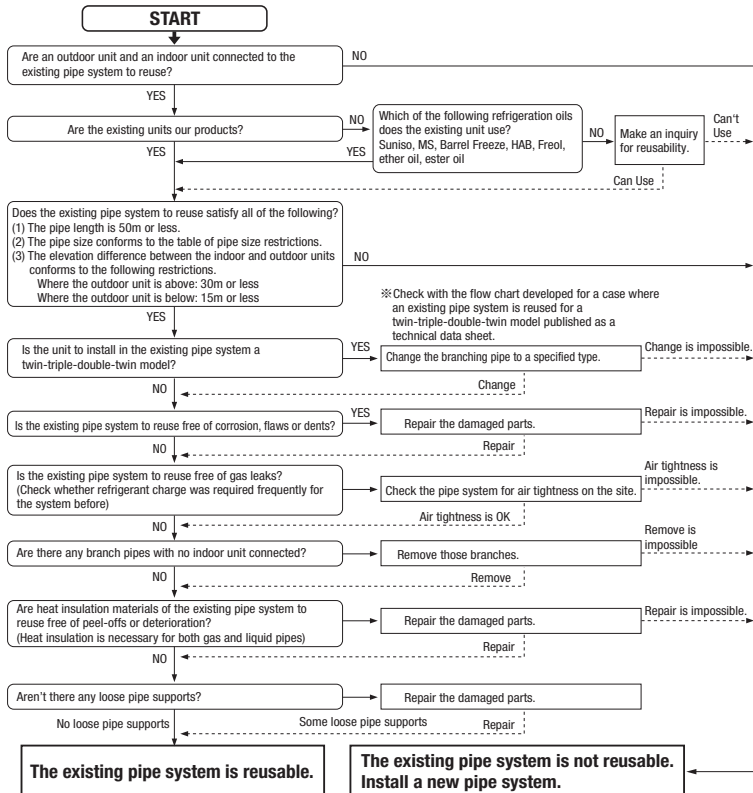

WARNING <Where the existing unit can be run for a cooling operation.>

Carry out the following steps with the existing unit (in the order of (1), (2), (3) and (4))

- (1) Run the unit for 30 minutes for a cooling operation.
- (2) Stop the indoor fan and run the unit for 3 minutes for a cooling operation (returning liquid)
- (3) Close the liquid side operation valve of the outdoor unit and pump down (refrigerant recovery)
- (4) Blow with nitrogen gas. ※ If discolored refrigeration oil or any foreign matters is discharged by the blow, wash the pipe system or install a new pipe system.
 - For the flare nut, do not use the old one, but use the one supplied with the outdoor unit. Process a flare to the dimensions specified for R410A.
 - Turn on-site setting SW5-1 to the ON position. (Where the gas pipe size is ϕ 19.05)

<Where the existing unit cannot be run for a cooling operation.>

- Wash the pipe system or install a new pipe system.
- If you choose to wash the pipe system, contact our distributor in the area.

<Table of pipe size restrictions>

○:Standard pipe size ○:Usable
△:Restricted to shorter pipe length limits

Pipe size	Liquid pipe	0.06kg/m		0.08kg/m	
		ϕ 9.52	ϕ 12.7	ϕ 12.7	ϕ 15.88
100V	Gas pipe	ϕ 15.88	ϕ 19.05	ϕ 15.88	ϕ 19.05
	Usability	○	○※1	△	△※1
	Maximum one-way pipe length	50	50	25	25
125V	Gas pipe	ϕ 15.88	ϕ 19.05	ϕ 15.88	ϕ 19.05
	Usability	○	○※1	△	△※1
	Maximum one-way pipe length	50	50	25	25
140V	Gas pipe	ϕ 15.88	ϕ 19.05	ϕ 15.88	ϕ 19.05
	Usability	○	○※1	△	△※1
	Maximum one-way pipe length	50	50	25	25

※1 Because of its insufficient pressure resistance, the dip switch SW5-1 provided on the outdoor unit position for ϕ 19.05 \times t1.0.

(In the case of a twin-triple-double-twin mode to the case where ϕ 19.05 \times t1.0 is used after the first branching point.

However, you need not turn the dip switch position, if 1/2H pipes or pipes having 1.2 or less are used.

※2 When the main pipe length exceeds 40m, a pressure drop may be experienced due to pressure pipe system. Use ϕ 12.7 for the liquid main.

※3 Keep the total pipe length, not one-way pipe specified maximum pipe length.

● When refrigerant piping is shorter than 3m, reduce 1kg from factory charged volume and adjust to the specified amount.

● Any combinations of pipe sizes not listed in the table are not usable.

<Pipe system after the branching pipe>

○:Standard pipe size ○:Usable ×:Not usable

- Any combinations of pipe sizes not listed in the table or marked with × in the table are not usable.

Pipe size	Additional charging amount of refrigerant per 1m	After 1st branch ※4			After 2nd branch			
		0.06kg/m			0.06kg/m			
	Liquid pipe	ϕ 9.52	ϕ 12.7	ϕ 15.88	ϕ 19.05※1	ϕ 12.7	ϕ 15.88	ϕ 19.05※1
	Gas pipe	ϕ 12.7	ϕ 15.88	ϕ 19.05※1	ϕ 12.7	ϕ 15.88	ϕ 19.05※1	
Model	Combination type	Combination of capacity						
100V	Twin	50+50	○	○	×	—	—	—
		60+60	○	○	×	—	—	—
125V	Twin	71+71	×	○	○	—	—	—
		50+50+50	○	○	×	—	—	—
140V	Triple A	50+50+50	○	○	×	—	—	—
		50+50+50	×	○※5	○※5	○	○	×

※4 Piping size after branch should be equal or smaller than main pipe size.

※5 Piping size from first branch to indoor unit should be ϕ 9.52 (Liquid) / ϕ 12.7 (Gas).

<The model types of existing units of which branching pipes are reusable.>

Models later than Type 8.

- FDC * * * 8
- FDCP * * * 8

The branching pipes used with models other than those listed above are not reusable because of their pressure resistance. Please use our genuine branching pipes for R410A.

- * * * are numbers representing horsepower. is an alphanumeric letter.

Formula to calculate additional charge volume

Additional charge volume (kg) = (Main pipe length (m) - Length covered without additional charge shown in the table) \times Additional charge volume per meter of pipe shown in the table
+ (Total length of branch pipes (m) \times Additional charge volume per meter of pipe shown in the table)

※ If you obtain a negative figure as a result of calculation, no additional refrigerant needs to be charged.

Example) When a 140V (single installation) is installed in a 20m long existing pipe system (liquid ϕ 12.7, gas ϕ 15.88), the quantity of refrigerant to charge additionally should be (20m-15m) \times 0.08kg/m = 0.4 kg.

(d) Models FDC200, 250VS

Inverter driven single split PAC

200V - 250V

Designed for R410A refrigerant

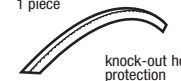
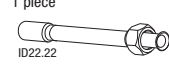
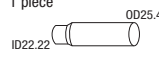

- ⊙ This installation manual deals with outdoor units and general installation specifications only. For indoor units, refer to the respective installation manuals supplied with the units.
- ⊙ When install the unit, be sure to check whether the selection of installation place, power supply specifications, usage limitation (piping length, height differences between indoor and outdoor units, power supply voltage and etc.) and installation spaces

Check before installation work**[Accessory]**

Edging	Accessory pipe	
1 piece  knock-out hole protection	1 piece ID22.22  Accessory pipe A	1 piece ID22.22 OD25.4  Accessory pipe B

- Model name and power source
- Refrigerant piping length
- Piping, wiring and miscellaneous small parts
- Indoor unit installation manual

SAFETY PRECAUTIONS

- We recommend you to read this "SAFETY PRECAUTIONS" carefully before the installation work in order to gain full advantage of the functions of the unit and to avoid malfunction due to mishandling.
 - The precautions described below are divided into **WARNING** and **CAUTION**. The matters with possibilities leading to serious consequences such as death or serious personal injury due to erroneous handling are listed in the **WARNING** and the matters with possibilities leading to personal injury or damage of the unit due to erroneous handling including probability leading to serious consequences in some cases are listed in **CAUTION**. **These are very important precautions for safety. Be sure to observe all of them without fail.**
 - The meaning of "Marks" used here are as shown below.
- | | |
|---|---|
|  Never do it under any circumstance. |   Always do it according to the instruction |
|---|---|
- For this outdoor unit, EN61000-3-2 is not applicable if consent by the utility company or notification to the utility company is given before usage.
 - Be sure to confirm no anomaly on the equipment by commissioning after completed installation and explain the operating methods as well as the maintenance methods of this equipment to the user according to the owner's manual.
 - Keep the installation manual together with owner's manual at a place where any user can read at any time. Moreover if necessary, ask to hand them to a new user

**WARNING**

- | | |
|---|--|
| <p>!</p> <ul style="list-style-type: none"> ● Installation must be carried out by the qualified installer.
If you install the system by yourself, it may cause serious trouble such as water leaks, electric shocks, fire and personal injury, as a result of a system malfunction. ● Install the system in full accordance with the instruction manual.
Incorrect installation may cause bursts, personal injury, water leaks, electric shocks and fire. ● Use the original accessories and the specified components for installation.
If parts other than those prescribed by us are used, it may cause fall of the unit, water leaks, electric shocks, fire, refrigerant leak, substandard performance, control failure and personal injury. ● When installing in small rooms, take prevention measures not to exceed the density limit of refrigerant in the event of leakage accordance with ISO5149.
Consult the expert about prevention measures. If the density of refrigerant exceeds the limit in the event of leakage, lack of oxygen can occur, which can cause serious accidents. ● Ventilate the working area well in the event of refrigerant leakage during installation.
If the refrigerant comes into contact with naked flames, poisonous gas is produced. ● After completed installation, check that no refrigerant leaks from the system.
If refrigerant leaks into the room and comes into contact with an oven or other hot surface, poisonous gas is produced. ● Hang up the unit at the specified points with ropes which can support the weight in lifting for portage. And to avoid jolting out of alignment, be sure to hang up the unit at 4-point support.
An improper manner of portage such as 3-point support can cause death or serious personal injury due to falling of the unit ● Install the unit in a location with good support.
Unsuitable installation locations can cause the unit to fall and cause material damage and personal injury. ● Ensure the unit is stable when installed, so that it can withstand earthquakes and strong winds.
Unsuitable installation locations can cause the unit to fall and cause material damage and personal injury. ● The electrical installation must be carried out by the qualified electrician in accordance with "the norm for electrical work" and "national wiring regulation", and the system must be connected to the dedicated circuit.
Power supply with insufficient capacity and incorrect function done by improper work can cause electric shocks and fire, ● Be sure to shut off the power before starting electrical work.
Failure to shut off the power can cause electric shocks, unit failure or incorrect function of equipment. ● Be sure to use the cables conformed to safety standard and cable ampacity for power distribution work.
Unconformable cables can cause electric leak, anomalous heat production or fire. ● Use the prescribed cables for electrical connection, tighten the cables securely in terminal block and relieve the cables correctly to prevent overloading the terminal blocks.
Loose connections or cable mountings can cause anomalous heat production or fire. ● Arrange the wiring in the control box so that it cannot be pushed up further into the box. Install the service panel correctly.
Incorrect installation may result in overheating and fire. | <p>!</p> <ul style="list-style-type: none"> ● Do not perform brazing work in the airtight room
It can cause lack of oxygen. ● Use the prescribed pipes, flare nuts and tools for R410A.
Using existing parts (for R22 or R407C) can cause the unit failure and serious accidents due to burst of the refrigerant circuit. ● Tighten the flare nut by using double spanners and torque wrench according to prescribed method. Be sure not to tighten the flare nut too much.
Loose flare connection or damage on the flare part by tightening with excess torque can cause burst or refrigerant leaks which may result in lack of oxygen. ● Do not open the service valves for liquid line and gas line until completed refrigerant piping work, air tightness test and evacuation.
If the compressor is operated in state of opening service valves before completed connection of refrigerant piping work, you may incur frost bite or injury from an abrupt refrigerant outflow and air can be sucked into refrigerant circuit, which can cause burst or personal injury due to anomalously high pressure in the refrigerant ● Only use prescribed optional parts. The installation must be carried out by the qualified installer.
If you install the system by yourself, it can cause serious trouble such as water leaks, electric shocks, fire. ● Do not perform any change of protective device itself or its setup condition
The forced operation by short-circuiting protective device of pressure switch and temperature controller or the use of non specified component can cause fire or burst. ● Be sure to switch off the power supply in the event of installation, inspection or servicing.
If the power supply is not shut off, there is a risk of electric shocks, unit failure or personal injury due to the unexpected start of fan. ● Consult the dealer or an expert regarding removal of the unit.
Incorrect installation can cause water leaks, electric shocks or fire. ● Stop the compressor before closing valve and disconnecting refrigerant pipes in case of pump down operation.
If disconnecting refrigerant pipes in state of opening service valves before compressor stopping, you may incur frost bite or injury from an abrupt refrigerant outflow and air can be sucked, which can cause burst or personal injury due to anomalously high pressure in the refrigerant circuit <p>⊘</p> <ul style="list-style-type: none"> ● Ensure that no air enters in the refrigerant circuit when the unit is installed and removed.
If air enters in the refrigerant circuit, the pressure in the refrigerant circuit becomes too high, which can cause burst and personal injury. ● Do not run the unit with removed panels or protections
Touching rotating equipments, hot surfaces or high voltage parts can cause personal injury due to entrapment, burn or electric shocks. ● Be sure to fix up the service panels.
Incorrect fixing can cause electric shocks or fire due to intrusion of dust or water. ● Do not perform any repairs or modifications by yourself. Consult the dealer if the unit requires repair.
If you repair or modify the unit, it can cause water leaks, electric shocks or fire. |
|---|--|

Notabilia as a unit designed for R410A

- Do not use any refrigerant other than R410A. R410A will rise to pressure about 1.6 times higher than that of a conventional refrigerant. A cylinder containing R410A has a pink indication mark on the top.
- A unit designed for R410A has adopted a different size indoor unit operation valve charge port and a different size check joint provided in the unit to prevent the charging of a wrong refrigerant by mistake. The processed dimension of the flared part of a refrigerant pipe and a flare nut's parallel side measurement have also been altered to raise strength against pressure. Accordingly, you are required to arrange dedicated R410A tools listed in the table on the right before installing or servicing this unit.
- Do not use a charge cylinder. The use of a charge cylinder will cause the refrigerant composition to change, which results in performance degradation.
- In charging refrigerant, always take it out from a cylinder in the liquid phase.
- All indoor units must be models designed exclusively for R410A. Check connectable indoor unit models in a catalog, etc. (A wrong indoor unit, if connected into the system, will impair proper system operation)

Dedicated R410A tools	
a)	Gauge manifold
b)	Charge hose
c)	Electronic scale for refrigerant charging
d)	Torque wrench
e)	Flare tool
f)	Protrusion control copper pipe gauge
g)	Vacuum pump adapter
h)	Gas leak detector

1. HAULAGE AND INSTALLATION (Take particular care in carrying in or moving the unit, and always perform such an operation with two or more persons)

CAUTION When a unit is hoisted with slings for haulage, take into consideration the offset of its gravity center position. If not properly balanced, the unit can be thrown off-balance and fall.

1) Delivery

- Deliver the unit as close as possible to the installation site before removing it from the packaging.
- When some compelling reason necessitates the unpacking of the unit before it is carried in, use nylon slings or protective wood pieces so as not to damage the unit by ropes lifting it.

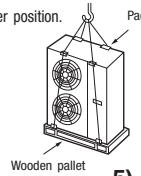

2) Portage

- The right hand side of the unit as viewed from the front (diffuser side) is heavier. A person carrying the right hand side must take heed of this fact. A person carrying the left hand side must hold with his right hand the handle provided on the front panel of the unit and with his left hand the corner column section.



3) Selection of installation location for the outdoor unit

Be sure to select a suitable installation place in consideration of following conditions.

- A place where it is horizontal, stable and can endure the unit weight and will not allow vibration transmittance of the unit.
- A place where it can be free from possibility of bothering neighbors due to noise or exhaust air from the unit
- A place where the unit is not exposed to oil splashes.
- A place where it can be free from danger of flammable gas leakage.
- A place where drain water can be disposed without any trouble.
- A place where the unit will not be affected by heat radiation from other heat source.
- A place where snow will not accumulate.
- A place where the unit can be kept away 5m or more from TV set and/or radio receiver in order to avoid any radio or TV interference.
- A place where good air circulation can be secured, and enough service space can be secured for maintenance and service of the unit safely.
- A place where the unit will not be affected by electromagnetic waves and/or high-harmonic waves generated by other equipment.
- A place where chemical substances like sulfuric gas, chloric gas, acid and alkali (including ammonia), which can harm the unit, will not be generated and not remain.
- A place where strong wind will not blow against the outlet air blow of the unit

4) Caution about selection of installation location

- (1) If the unit is installed in the area where the snow will accumulate, following measures are required. The bottom plate of unit and intake, outlet may be blocked by snow.

1. Install the unit on the base so that the bottom is higher than snow cover surface.

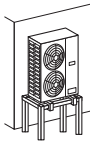

2. Provide a snow hood to the outdoor unit on site. Regarding outline of a snow hood, refer to our technical manual.

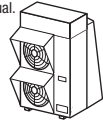

3. Install the unit under eaves or provide the roof on site.

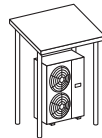

Since drain water generated by defrost control may freeze, following measures are required.

- Don't execute drain piping work by using a drain elbow and drain grommets (optional parts). [Refer to Drain piping work.]
- Recommend setting Defrost Control (SW3-1) and Snow Guard Fan Control (SW3-2). [Refer to Setting SW3-1, SW3-2.]

- (2) If the unit can be affected by strong wind, following measures are required.

Strong wind can cause damage of fan (fan motor), or can cause performance degradation, or can trigger anomalous stop of the unit due to rising of high pressure.

- Install the outlet air blow side of the unit to face a wall of building, or provide a fence or a windbreak screen.
- Install the outlet air blow side of the unit in a position perpendicular to the direction of wind.
- The unit should be installed on the stable and level foundation. If the foundation is not level, tie down the unit with wires.

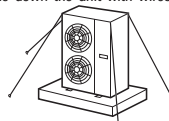
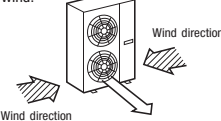
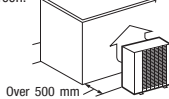

5) Installation space

- Walls surrounding the unit in the four sides are not acceptable.
- There must be a 1-meter or larger space in the above.
- Where a danger of short-circuiting exists, install guide louvers.
- When more than one unit are installed, provide sufficient intake space consciously so that short-circuiting may not occur.
- Where piling snow can bury the outdoor unit, provide proper snow guards.
- A barrier wall placed in front of the exhaust diffuser must not be higher than the unit.

Size	200V, 250V (mm)		
	I	II	III
L1	Open	Open	500
L2	300	5	Open
L3	150	300	150
L4	5	5	5

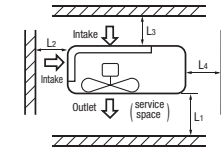

6) Installation

- ① Anchor bolt fixed position

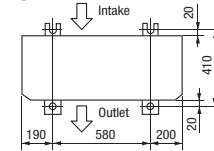

- ② Notabilia for installation

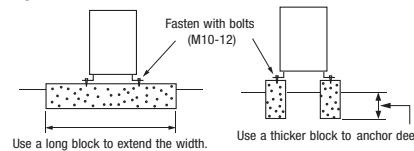

- In installing the unit, fix the unit's legs with bolts specified on the left.
 - The protrusion of an anchor bolt on the front side must be kept within 15 mm.
 - Securely install the unit so that it does not fall over during earthquakes or strong winds, etc.
 - Refer to the left illustrations for information regarding concrete foundations.
 - Install the unit in a level area. (With a gradient of 5 mm or less.)
- Improper installation can result in a compressor failure, broken piping within the unit and abnormal noise generation.

7) To run the unit for a cooling operation, when the outdoor temperature is -5°C or lower.

- When the outdoor air temperature is -5°C or lower, provide a snow hood to the outdoor unit on site. So that strong wind will not blow against the outdoor heat exchanger directly. Regarding outline of a snow hood refer to our technical manual.

2. REFRIGERANT PIPING WORK

1) Restrictions on unit installation and use

- Check the following points in light of the indoor unit specifications and the installation site.
- Observe the following restrictions on unit installation and use. Improper installation can result in a compressor failure or performance degradation.

Restrictions	One-way pipe length difference from the first branching point to the indoor unit		Marks appearing in the drawing				
	Model for outdoor units	Dimensional restrictions	Single type	Twin type	Triple type A	Triple type B	W-twin type
One-way pipe length of refrigerant piping	200V Liquid Piping	φ9.52 φ12.7	≤ 40m	L	L+L1, L+L2, L+L3	L+L1 (n)	L+La+L1, L+La+L2 L+Lb+L3, L+Lb+L4
	200V/250V Gas piping	φ25.4 or φ28.58 φ22.22	≤ 70m ≤ 35m	—	L+L1, L+La+L2, L+La+L3 (φ type B)	Prohibition of the use	—
Main pipe length	200V Liquid Piping	φ9.52 φ12.7	≤ 40m	—	L	L+L1 (n)	L
	200V/250V Gas piping	φ25.4 or φ28.58 φ22.22	≤ 70m ≤ 35m	—	—	Prohibition of the use	—
One-way pipe length between the first branching point from the second branching point to the indoor unit	200V	—	≤ 5m	—	La	Prohibition of the use	—
One-way pipe length after the first branching point	200V	—	≤ 30m	—	L1, L2, L3	L1 (n)	La+L1, L+La+L2 Lb+L3, Lb+L4
	250V	—	≤ 30m	—	L1, La+L2, L+La+L3 (φ type B)	Prohibition of the use	—
One-way pipe length after the first branching point and second branching point	200V	—	≤ 27m	—	—	La+L2, La+L3 (n)	—
	Twin type	—	≤ 10m	—	—	—	—
One-way pipe length difference from the first branching point to the indoor unit	Triple type	200V	≤ 3m	—	L1-L2 , L2-L3 , L3-L1	—	—
	250V	—	≤ 10m	—	—	L1-(La+L2), L1-(La+L3) (n)	—
	W-twin type	200V/250V	≤ 3m	—	L1-(La+L2) , L1-(La+L3) , L2-L3 (φ type B)	Prohibition of the use	—
One-way pipe length difference from the second branching point to the indoor unit	200V	—	≤ 10m	—	—	—	L1-L2 , L3-L4 (L1+La)-(L3+Lb) , L1+La-(L4+Lb) (L2+Lb)-(L3+Lb) , (L2+Lb)-(L4+Lb)
	250V	—	≤ 15m	—	—	L2-L3	L1-L2 , L3-L4
Total pipe length after the second branching point	200V	—	≤ 15m	—	—	—	L1+L2, L3+L4
Elevation difference between indoor and outdoor units	When the outdoor unit is positioned higher.	—	≤ 30m	H	H	H	H
	When the outdoor unit is positioned lower.	—	≤ 15m	—	—	—	—
Elevation difference between indoor units	—	—	≤ 0.5m	—	h1, h2, h3	h1, h2, h3	h1, h2, h3, h4, h5, h6

- CAUTION**
- For model 200V, always use φ12.7mm liquid pipes, when the length of the main "L" exceeds 40m. If φ9.52mm pipes are used in an installation having over 40m piping, they can cause performance degradation and/or water leaks from an indoor unit.
 - The use restrictions appearing in the table above are applicable to the standard pipe size combinations shown in the table below. Where an existing pipe system is utilized, different one-way pipe length restrictions should apply depending on its pipe size. For more information, see "6. UTILIZATION OF EXISTING PIPING."
 - With the triple pipe connection, the way of use is different when the difference of one-way pipe length after the first branching point is 3m to 10m. For details, refer to the above table and right figure.
- Note (1) Install the indoor units so that L + L1 becomes the longest one-way pipe.
Keep the pipe length difference between L1 and (La + L2) or (La + L3) within 10m.
Note (2) Connect the unit that is the maximum capacity with L1.

2) Determination of pipe size

- Determine refrigerant pipe size pursuant to the following guidelines based on the indoor unit specifications.

Outdoor unit connected	Model 200V				Model 250V				
	Gas pipe	Liquid pipe	Gas pipe	Liquid pipe	Gas pipe	Liquid pipe	Gas pipe	Liquid pipe	
Refrigerant piping (branch pipe)	φ22.22	φ9.52	φ22.22	φ12.7	φ22.22	φ12.7	φ22.22	φ12.7	
Indoor unit connected	φ25.4	φ9.52 or φ12.7	φ25.4	φ12.7	φ22.22	φ12.7	φ22.22	φ12.7	
In the case of a single type	Capacity of indoor unit	Model 200V, Model VA80		Model 250V, Model VA100		—		—	
	Branching pipe set	DIS-WB1		DIS-WB1		—		—	
In the case of a twin type	Refrigerant piping (branch pipe L1, L2)	φ15.88	φ9.52	φ15.88	φ9.52	—		—	
	Indoor unit connected	φ15.88	φ9.52	φ15.88	φ9.52	—		—	
In the case of a triple type A	Capacity of indoor unit	Model 100V×2, Model VA40×2		Model 125V×2, Model VA50×2		—		—	
	Branching pipe set	DIS-TB1		DIS-TB1		—		—	
In the case of a triple type B	Refrigerant piping (branch pipe La, L1)	φ15.88	φ9.52	φ15.88	φ9.52	φ15.88	φ9.52	φ15.88	φ9.52
	Indoor unit connected	φ15.88	φ9.52	φ15.88	φ9.52	φ15.88	φ9.52	φ15.88	φ9.52
In the case of a W-twin type	Capacity of indoor unit	Model 71V×3, Model VA30×3		Model 60V×2+ Model 125V		Model 71V×2+ Model 100V		Model VA25×2+ Model VA50	
	Branching pipe set	DIS-WA1		DIS-WB1		DIS-WA1		DIS-WB1	
In the case of a triple type B	Refrigerant piping (branch pipe L2, L3)	φ15.88	φ9.52	φ12.7	φ9.52	φ15.88	φ9.52	φ15.88	φ9.52
	Indoor unit connected	φ15.88	φ9.52	φ12.7	φ9.52	φ15.88	φ9.52	φ15.88	φ9.52
In the case of a W-twin type	Capacity of indoor unit	Model 71V×3, Model VA30×3		Model 60V×2+ Model 125V		Model 71V×2+ Model 100V		Model VA25×2+ Model VA50	
	Branching pipe set	DIS-WA1		DIS-WB1		DIS-WA1		DIS-WB1	
In the case of a triple type B	Refrigerant piping (branch pipe La, Lb)	φ15.88	φ9.52	φ15.88	φ9.52	φ15.88	φ9.52	φ15.88	φ9.52
	Indoor unit connected	φ15.88	φ9.52	φ15.88	φ9.52	φ15.88	φ9.52	φ15.88	φ9.52
In the case of a W-twin type	Capacity of indoor unit	Model 50V×4, Model VA20×4		Model 60V×4		Model 71V×2+ Model 100V		Model VA25×2+ Model VA50	
	Branching pipe set	DIS-WA1		DIS-WB1		DIS-WA1		DIS-WB1	
In the case of a triple type B	Refrigerant piping (branch pipe L1, L2, L3, L4)	φ12.7	φ9.52	φ12.7	φ9.52	φ12.7	φ9.52	φ12.7	φ9.52
	Indoor unit connected	φ12.7	φ9.52	φ12.7	φ9.52	φ12.7	φ9.52	φ12.7	φ9.52
In the case of a W-twin type	Capacity of indoor unit	Model 50V×4, Model VA20×4		Model 60V×4		Model 71V×2+ Model 100V		Model VA25×2+ Model VA50	
	Branching pipe set	DIS-WA1		DIS-WB1		DIS-WA1		DIS-WB1	

- CAUTION**
- When the model 50V or model 60V model is connected as an indoor unit, always use a φ9.52 liquid pipe for the branch (branching pipe – indoor unit) and a different diameter joint supplied with the branching pipe set for connection with the indoor unit (φ6.35 on the liquid pipe side).
If a φ6.35 pipe is used for connection with a branching pipe, a refrigerant distribution disorder may occur, causing one of the indoor units to fall short of the rated capacity.
 - A riser pipe must be a part of the main. A branching pipe set should be installed horizontally at a point as close to an indoor unit as possible.
A branching part must be dressed with a heat-insulation material supplied as an accessory.
 - For the details of installation work required at and near a branching area, see the installation manual supplied with your branching pipe set.

3) How to use pipe reducer.

- φ22.22(OD) size of the refrigerant gas pipe can be used by using accessory pipe A, B.
- φ25.4(OD) size of the refrigerant gas pipe can be used by using accessory pipe A and joint pipe C.
- φ28.58(OD) size of the refrigerant gas pipe can be used by using accessory pipe A and joint pipe C, D.

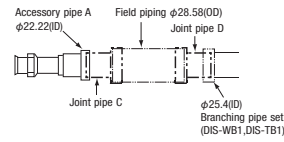
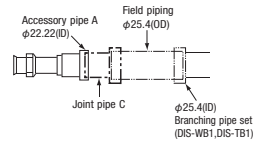
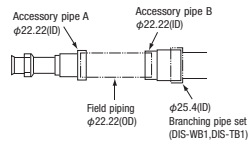

< Single type >

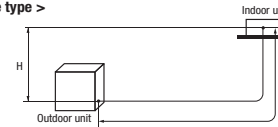

< Twin type >

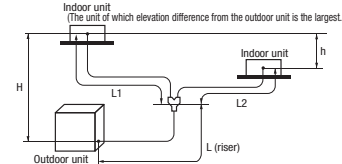

< Triple type >

Type A

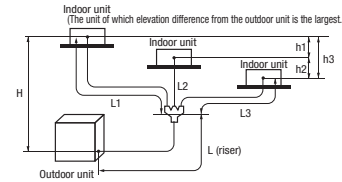

< Triple type >

Type B

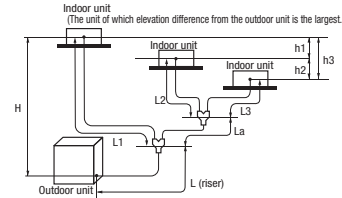

< W-twin type >

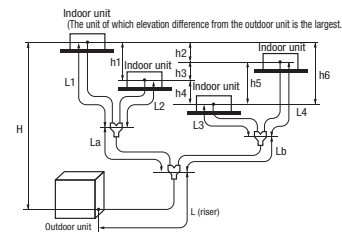

About brazing

Brazing must be performed under a nitrogen gas flow.

Without nitrogen gas, a large quantity of foreign matters (oxidized film) are created, causing a critical failure from capillary tube or expansion valve clogging.

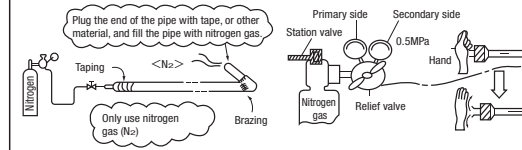

4) Refrigerant pipe wall thickness and material

- Select refrigerant pipes of the table shown on the right wall thickness and material as specified for each pipe size.
- This unit uses R410A. Always use 1/2H pipes having a 1.0mm or thicker wall for φ19.05 or larger pipes, because O-type pipes do not meet the pressure resistance requirement.

Pipe diameter (mm)	6.35	9.52	12.7	15.88	22.22	25.4	28.58
Minimum pipe wall thickness (mm)	0.8	0.8	0.8	1.0	1.0	1.0	1.0
Pipe material*	O-type pipe	O-type pipe	O-type pipe	O-type pipe	1/2H-type pipe	1/2H-type pipe	1/2H-type pipe

NOTE

- Select pipes having a wall thickness larger than the specified minimum pipe thickness.

*Phosphorus deoxidized seamless copper pipe C1220T, JIS H3300

5) On-site piping work

IMPORTANT

- Take care so that installed pipes may not touch components within a unit. If touching with an internal component, it will generate abnormal sounds and/or vibrations.

How to remove the service panel

First remove the five screws (✕ mark) of the service panel and push it down into the direction of the arrow mark and then remove it by pulling it toward you.

- The pipe can be laid in any of the following directions: side right, front, rear and downward.
- Remove a knock-out plate provided on the pipe penetration to open a minimum necessary area and attach an edging material supplied as an accessory by cutting it to an appropriate length before laying a pipe.
- Carry out the on site piping work with the operation valve fully closed.
- Give sufficient protection to a pipe end (compressed and blazed, or with an adhesive tape) so that water or foreign matters may not enter the piping.
- Bend a pipe to a radius as large as practical.(R100~R150) Do not bend a pipe repeatedly to correct its form.
- Flare connection is used between the unit and refrigerant pipe. Flare a pipe after engaging a flare nut onto it. Flare dimensions for R410A are different from those for conventional R407C. Although we recommend the use of flaring tools designed specifically for R410A, conventional flaring tools can also be used by adjusting the measurement of protrusion B with a protrusion control gauge.
- Use accessory pipes.

For detailed installation procedures, consult with the installation manual attached to your accessory pipe.

- The pipe should be anchored every 1.5m or less to isolate the vibration.
- Tighten a flare joint securely with a double spanner.

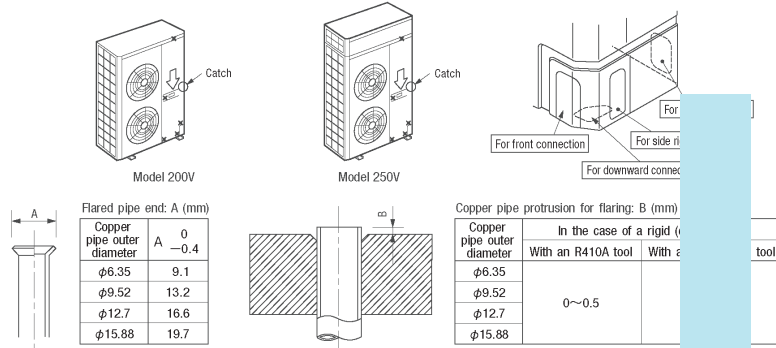

CAUTION

Do not apply force beyond proper fastening torque in tightening the flare nut.

Fix both liquid and gas service valves at the valve main bodies as illustrated on the right, and then fasten them, applying appropriate fastening torque.

Operation valve size (mm)	Tightening torque (N·m)	Tightening angle (°)	Recommended length of a tool handle (mm)
φ6.35 (1/4")	14~18	45~60	150
φ9.52 (3/8")	34~42	30~45	200
φ12.7 (1/2")	49~61	30~45	250
φ15.88(5/8")	68~82	15~20	300
φ19.05(3/4")	100~120	15~20	450

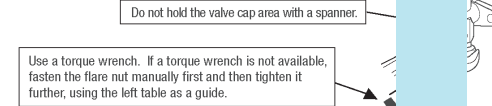

6) Air tightness test

- Although outdoor and indoor units themselves have been tested for air tightness at the factory, check the connecting pipes after the installation work for air tightness from the operation valve's check joint equipped on the outdoor unit side. While conducting a test, keep the operation valve shut all the time.
 - Raise the pressure to 0.5 MPa, and then stop. Leave it for five minutes to see if the pressure drops.
 - Then raise the pressure to 1.5 MPa, and stop. Leave it for five more minutes to see if the pressure drops.
 - Then raise the pressure to the specified level (4.15 MPa), and record the ambient temperature and the pressure.
 - If no pressure drop is observed with an installation pressurized to the specified level and left for about one day, it is acceptable. When the ambient Temperature fall 1°C, the pressure also fall approximately 0.01 MPa. The pressure, if changed, should be compensated for.
 - If a pressure drop is observed in checking e) and a) - d), a leak exists somewhere. Find a leak by applying bubble test liquid to welded parts and flare joints and repair it. After repair, conduct an air-tightness test again.
- In conducting an air-tightness test, use nitrogen gas and pressurize the system with nitrogen gas from the gas side. Do not use a medium other than nitrogen gas under any circumstances.

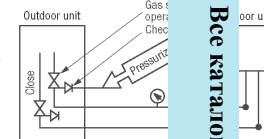

7) Evacuation

<Work flow>

When the system has remaining moisture inside or a leaky point, the vacuum gauge indicator will rise. Check the system for a leaky point and then draw air to create a vacuum again.

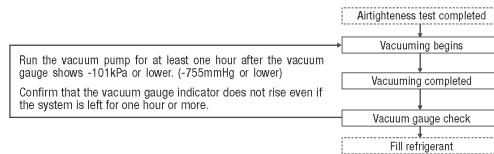

Pay attention to the following points in addition to the above for the R410A and compatible refrigerants.

- To prevent a different oil from entering, assign dedicated tools, etc. to each refrigerant type. Under no circumstances must a gauge manifold and a charge hose in particular be shared with other refrigerant types (R22, R410A).
- Use a counterflow prevention adapter to prevent vacuum pump oil from entering the refrigerant system.

8) Additional refrigerant charge

(1) Calculate a required refrigerant charge volume from the following table.

<Single type>

Item	Standard refrigerant charge volume (kg)	Pipe length for standard refrigerant charge volume (m)	Additional charge volume (kg) per meter of refrigerant piping (liquid pipe)	Refrigerant volume charged for shipment at the factory (kg)	Installation's pipe length (m) covered without additional refrigerant charge
Model 200V	3.6	0	0.06 (Liquid piping φ9.52)	5.4	30
			0.12 (Liquid piping φ12.7)		
Model 250V			0.12	7.2	

<Twin, triple, W-twin type>

Item	Standard refrigerant charge volume (kg)	Pipe length for standard refrigerant charge volume (m)	Additional charge volume (kg) per meter of refrigerant piping (liquid pipe)		Refrigerant volume charged for shipment at the factory (kg)	Installation's pipe length (m) covered without additional refrigerant charge
			Main pipe	Branch pipe		
Model V200	3.6	0	0.06		5.4	30
Model V250			0.12	0.06		

- A standard refrigerant charge volume means a refrigerant charge volume for an installation with 0m long refrigerant piping.
- This unit contains factory charged refrigerant covering 30m of refrigerant piping and additional refrigerant charge on the installation site is not required for an installation with up to 30m refrigerant piping. When refrigerant piping exceeds 30m, additionally charge an amount calculated from the pipe length and the above table for the portion in excess of 30m.
- When refrigerant piping is shorter than 3m, reduce refrigerant by 1kg from factory charged volume and adjust to 4.4kg(Model 200V) or 6.2kg(Model 250V).**
- If an existing pipe system is used, a required refrigerant charge volume will vary depending on the liquid pipe size. For further information, see " 6. UTILIZATION OF EXISTING PIPING."

Formula to calculate the volume of additional refrigerant required

Model 200V	In the case of φ9.52mm liquid piping	Additional charge volume (kg) = { Main pipe length (m) - Length covered without additional charge 30 (m) } x 0.06 (kg/m) + Total length of branch pipes (m) x 0.06 (kg/m)
Model 250V	In the case of φ12.7mm liquid piping	Additional charge volume (kg) = { Main pipe length (m) - Length covered without additional charge 30 (m) } x 0.12 (kg/m) + Total length of branch pipes (m) x 0.06 (kg/m)

*When an additional charge volume calculation results in a negative value, it is not necessary to charge refrigerant additionally.

- To charge refrigerant again, recover refrigerant from the system first and then charge the volume calculated from the above table (Standard refrigerant charge volume + branch pipes charge volume)**

(2) Charging refrigerant

- Since R410A refrigerant must be charged in the liquid phase, you should charge it, keeping the container cylinder upside down or using a refrigerant cylinder equipped with a siphon tube.
- Charge refrigerant always from the liquid side service port with the operation valve shut. When you find it difficult to charge a required amount, fully open the outdoor unit valves on both liquid and gas sides and charge refrigerant from the gas (suction) side service port, while running the unit in the cooling mode. In doing so, care must be taken so that refrigerant may be discharged from the cylinder in the liquid phase all the time. When the cylinder valve is throttled down or a dedicated conversion tool to change liquid-phase refrigerant into mist is used to protect the compressor, however, adjust charge conditions so that refrigerant will gasify upon entering the unit.
- In charging refrigerant, always charge a calculated volume by using a scale to measure the charge volume.
- When refrigerant is charged with the unit being run, complete a charge operation within 30 minutes. Running the unit with an insufficient quantity of refrigerant for a long time can cause a compressor failure.

NOTE Put down the refrigerant volume calculated from the pipe length onto the caution label attached on the back side of the service panel.

9) Heating and condensation prevention

- (1) Dress refrigerant pipes (both gas and liquid pipes) for heat insulation and prevention of dew condensation.
- (2) Use a heat insulating material that can withstand 120°C or a higher temperature. Poor heat insulating capacity can cause heat insulation problems or cable deterioration.
 - Improper heat insulation/anti-dew dressing can result in a water leak or dripping causing damage to household effects, etc.
 - All gas pipes must be securely heat insulated in order to prevent damage from dripping water that comes from the condensation formed on them during a cooling operation or personal injury from burns because their surface can reach quite a high temperature due to discharged gas flowing inside during a heating operation.
 - Wrap indoor units' flare joints with heat insulating parts (pipe cover) for heat insulation (both gas and liquid pipes).
 - Give heat insulation to both gas and liquid side pipes. Bundle a heat insulating material and a pipe tightly together so that no gaps may be left between them and wrap them together with a connecting cable by a dressing tape.
 - Although it is verified in a test that this air conditioning unit shows satisfactory performance under JIS condensation test conditions, **both gas and liquid pipes need to be dressed with 20 mm or thicker heat insulation materials above the ceiling where relative humidity exceeds 70%.**

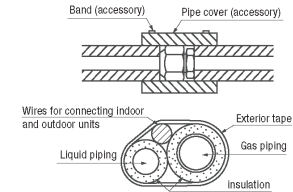

3. DRAIN PIPING WORK

- Execute drain piping by using a drain elbow and drain grommets supplied separately as optional parts, where water drained from the outdoor unit is a problem.

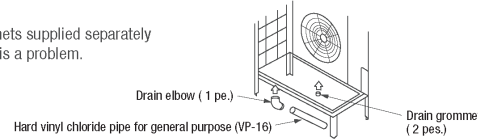

- There are 3 drain holes provided on the bottom plate of an outdoor unit to discharge condensed water.
- When condensed water needs to be led to a drain, etc., install the unit on a flat base (supplied separately as an optional part) or concrete blocks.
- Connect a drain elbow as shown in the illustration and close the other two drain holes with grommets.

4. ELECTRICAL WIRING WORK For details of electrical cabling, refer to the indoor unit installation manual.

Electrical installation work must be performed by an electrical installation service provider qualified by a power provider of the country. Electrical installation work must be executed according to the technical standards and other regulations applicable to electrical installations in the country.

- Do not use any supply cord lighter than one specified in parentheses for each type below.
 - braided cord (code designation 60245 IEC 51),
 - ordinary tough rubber sheathed cord (code designation 60245 IEC 53)
 - flat twin tinsel cord (code designation 60227 IEC 41);
- Do not use anything lighter than polychloroprene sheathed flexible cord (code designation 60245 IEC57) for supply cords of parts of appliances for outdoor use.
- Ground the unit. Do not connect the grounding wire to a gas pipe, water pipe, lightning rod or telephone grounding wire. If improperly grounded, an electric shock or malfunction may result.
- A grounding wire must be connected before connecting the power cable. Provide a grounding wire longer than the power cable.
- The installation of an impulse withstanding type earth leakage breaker is necessary. A failure to install an earth leakage breaker can result in an accident such as an electric shock or a fire.

- Do not turn on the power until the electrical work is completed.
- Do not use a condensive capacitor for power factor improvement under any circumstances. (It does not improve power factor, while it can cause an abnormal overheat accident)
- For power supply cables, use conduits.
- Do not lay electronic control cables (remote control and signaling wires) and other cables together outside the unit. Laying them together can result in the malfunctioning or a failure of the unit due to electric noises.
- Fasten cables so that they may not touch the piping, etc.
- When cables are connected, make sure that all electrical components within the electrical component box are free of loose connector coupling or terminal connection and then attach the cover securely. (Improper cover attachment can result in malfunctioning or a failure of the unit, if water penetrates into the box.)
- Always use a three-core cable for an indoor-outdoor connecting cable. Never use a shield cable.
- Connect a pair bearing a common terminal number with an indoor-outdoor connecting wire.
- In cabling, fasten cables securely with cable clamps so that no external force may work on terminal connections.
- Grounding terminals are provided in the control box.

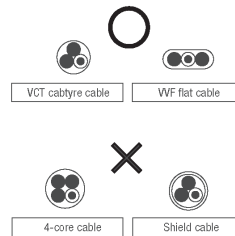
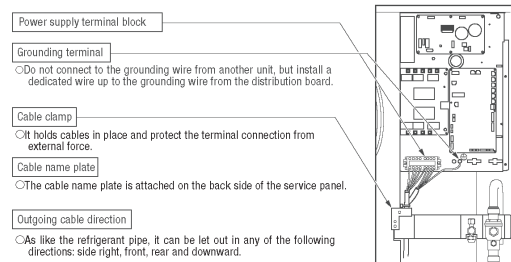

Power cable, indoor-outdoor connecting wires

- Always perform grounding system installation work with the power cord unplugged.



Always use an earth leakage circuit breaker designed for inverter circuits to prevent a faulty operation.

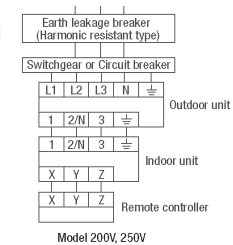

Model	Power source	Power cable thickness (mm ²)	MAX. over current (A)	Cable length (m)	Grounding wire thickness	Indoor-outdoor wire thickness × number
200V	3 phase 4 wire 380-415V 50Hz	3.5	19	21	φ1.6mm	φ1.6mm x 3
250V	380V 60Hz	5.5	22	31		

Model	Power source	Power cable thickness (mm ²)	MAX. over current (A)	Cable length (m)	Grounding wire thickness	Indoor-outdoor wire thickness × number
200V	3 phase 4 wire 380-415V 50Hz	5.5	24	29	φ1.6mm	φ1.6mm x 3
			27	26		

- The specifications shown in the above table are for units without heaters. For units with heaters, refer to the installation instructions or the construction instructions of the indoor unit.
- Switchgear or Circuit breaker capacity which is calculated from MAX. over current should be chosen along the regulations in each country.
- The cable specifications are based on the assumption that a metal or plastic conduit is used with no more than three cables contained in a conduit and a voltage drop is 2%. For an installation falling outside of these conditions, follow the internal cabling regulations. Adapt it to the regulation in effect in each country.

5. TEST RUN

WARNING

- Before conduct a test run, do not fail to make sure that the operation valves are closed.
- Turn on power 6 hours prior to a test run to energize the crank case heater.
- Always give a 3-minute or longer interval before you start the unit again whenever it is stopped.
- Removing the service panel will expose high-voltage live parts and high-temperature parts, which are quite dangerous. Take utmost care not to incur an electric shock or burns. Do not leave the unit with the service panel open.

A failure to observe these instructions can result in a compressor breakdown.

CAUTION

- When you operate switches (SW3, SW5) for on-site setting, be careful not to touch a live part.
- You cannot check discharge pressure from the liquid operation valve charge port.
- The 4-way valve (20S) is energized during a heating operation.
- When power supply is cut off to reset the unit, give 3 or more minutes before you turn on power again after power is cut off. If this procedure is not observed in turning on power again, "Communication error between outdoor and indoor unit" may occur.

1) Test run method

- (1) A test run can be initiated from an outdoor unit by using SW3-3 and SW3-4 for on-site setting.
- (2) Switching SW3-3 to ON will start the compressor.
- (3) The unit will start a cooling operation, when SW3-4 is OFF, or a heating operation, when SW3-4 is ON.
- (4) **Do not fail to switch SW3-3 to OFF when a test run is completed.**

SW-3-3	SW-3-4	
ON	OFF	Cooling during a test run
ON	ON	Heating during a test run
OFF	—	Normal or After the test operation

2) Checking the state of the unit in operation

Use check joints provided on the piping before and after the four-way valve installed inside the outdoor unit for checking discharge pressure and suction pressure. As indicated in the table shown on the right, pressure detected at each point will vary depending on whether a cooling or heating operation has been selected.

	Check joint of the pipe	Charge port of the gas operation valve
Cooling operation	Discharge pressure (High pressure)	Suction pressure (Low pressure)
Heating operation	Suction pressure (Low pressure)	Discharge pressure (High pressure)

3) Setting SW3-1, SW3-2, J7 on-site

- (1) Defrost control switching (SW3-1)
 - When this switch is turned ON, the unit will run in the defrost mode more frequently.
 - Set this switch to ON, when installed in a region where outdoor temperature falls below zero during the season the unit is run for a heating operation.
- (2) Snow guard fan control (SW3-2)
 - When this switch is turned on, the outdoor unit fan will run for 10 seconds in every 10 minutes, when outdoor temperature falls to 3°C or lower and the compressor is not running.
 - When the unit is used in a very snowy country, set this switch to ON.
- (3) High pressure control (J7)
 - When the option parts that change air flow from outlet are used, cut (open) J7.
 - Cut the jumper wire into two parts and ensure that they are kept isolated from each other.

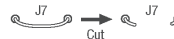

4) Failure diagnosis in a test run

Error indicated on the remote control unit	Printed circuit board LED (The cycles of 5 seconds)		Failure event	Action
	Red LED	Green LED		
E34	Blinking once	Blinking continuously	Open phase	Check power cables for loose contact or disconnection
E40	Blinking once	Blinking continuously	63H1 actuation or operation with operation valves shut (occurs mainly during a heating operation)	1. Check whether the operation valves are open. 2. If an error has been canceled when 3 minutes have elapsed since a compressor stop, you can restart the unit by effecting Check Reset from the remote control unit.
E49	Blinking once	Blinking continuously	Low pressure error or operation with operation valves shut (occurs mainly during a cooling operation)	

- If an error code other than those listed above is indicated, refer to the wiring diagram of the outdoor unit and the indoor unit.

5) The state of the electronic expansion valve.

The following table illustrates the steady states of the electronic expansion valve.

	When power is turned on	When the unit comes to a normal stop		When the unit comes to an abnormal stop	
		During a cooling operation	During a heating operation	During a cooling operation	During a heating operation
Valve for a cooling operation	Complete shut position	Complete shut position	Full open position	Full open position	Full open position
Valve for a heating operation	Full open position	Full open position	Complete shut position	Full open position	Full open position

6) Heed the following on the first operation after turning on the circuit breaker.

This outdoor unit may start in the standby mode (waiting for a compressor startup), which can continue up to 30 minutes, to prevent the oil level in the compressor from lowering on the first operation after turning on the circuit breaker. If that is the case, do not suspect a unit failure.

Items to check before a test run

- When you leave the outdoor unit with power on, be sure to close the panel.

Item No. used in the installation manual	Item	Check item	Check
2	Refrigerant plumbing	If brazed, was it brazed under a nitrogen gas flow?	
		Were air-tightness test and vacuum extraction surely performed?	
		Are heat insulation materials installed on both liquid and gas pipes?	
		Are operation valves surely opened for both liquid and gas systems?	
4	Electric wiring	Have you recorded the additional refrigerant charge volume and refrigerant pipe length on the	
		Is the unit free of cabling errors such as uncompleted connection, an absent or reverse	
		Are properly rated electrical equipments used for circuit breakers and cables?	
		Doesn't cabling cross-connect between units, where more than one unit are installed?	
		Aren't indoor-outdoor signal wires connected to remote control wires?	
		Do indoor-outdoor connecting cables connect between the same terminal numbers?	
		Are either VCT cabletyre cables or WF flat cables used for indoor-outdoor connecting c	
		Does grounding satisfy the D type grounding (Type III grounding) requirements?	
		Is the unit grounded with a dedicated grounding wire not connected to another unit's gro	
		Are cables free of loose screws at their connection points?	
—	Indoor unit	Are cables held down with cable clamps so that no external force works onto terminal c	
		Is indoor unit installation work completed?	
		Where a face cover should be attached onto an indoor unit, is the face cover attached to th	

Test run procedure

- Always carry out a test run and check the following in order.

Turn	The contents of operation	Check
①	Open the gas side operation valve fully.	
②	Open the liquid side operation valve fully.	
③	Close the panel.	
④	Where a remote control unit is used for unit setup on the installation site, please follow instructions for unit setup on the installation site with a remote control unit.	
⑤	SW3-3 ON / SW3-4 OFF: the unit will start a cooling operation. SW3-3 ON / SW3-4 ON: the unit will start a heating operation.	
⑥	When the unit starts operation, press the wind direction button provided on the remote control unit to check its operation.	
⑦	Place your hand before the indoor unit's diffuser to check whether cold (warm) winds come out in a cooling (heating) operation.	
⑧	Make sure that a red LED is not blinking.	
⑨	When you complete the test run, do not forget to turn SW3-3 to the OFF position.	
⑩	Where options are used, check their operation according to the respective instruction manuals.	

SWITCHES FOR ON-SITE SETTING

SW5



All set to OFF for shipment

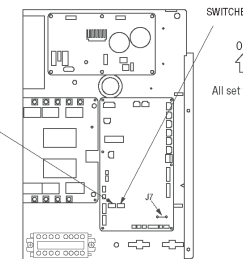

SWITCHES FOR ON-SITE SETTING

SW3

SW4

SW5

SW6

SW7

SW8

SW9

SW10

SW11

SW12

SW13

SW14

SW15

SW16

SW17

SW18

SW19

SW20

SW21

SW22

SW23

SW24

SW25

SW26

SW27

SW28

SW29

SW30

SW31

SW32

SW33

SW34

SW35

Model 200V, 250V

6. UTILIZATION OF EXISTING PIPING.

Check whether an existing pipe system is reusable or not by using the following flow chart.

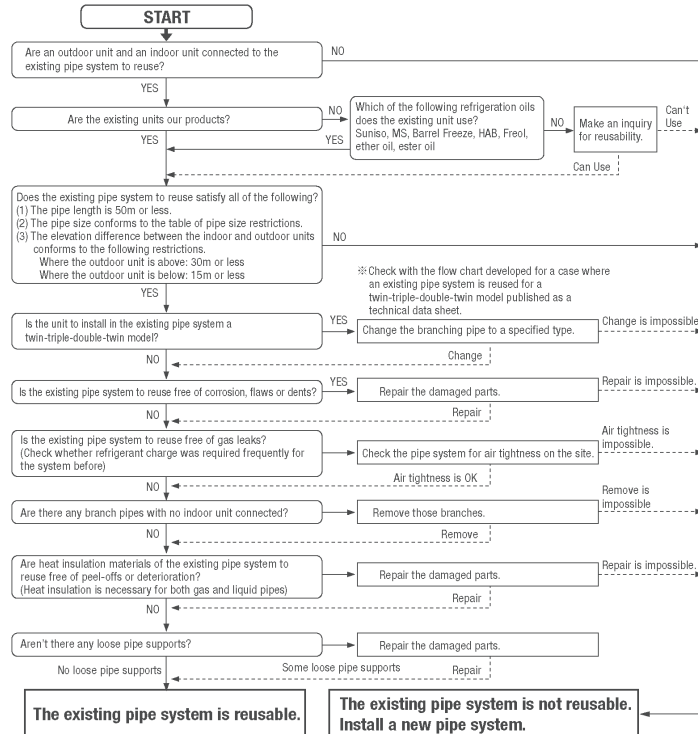

WARNING <Where the existing unit can be run for a cooling operation.>

Carry out the following steps with the existing unit (in the order of (1), (2), (3) and (4))

- (1) Run the unit for 30 minutes for a cooling operation.
- (2) Stop the indoor fan and run the unit for 3 minutes for a cooling operation (returning liquid)
- (3) Close the liquid side operation valve of the outdoor unit and pump down (refrigerant recovery)
- (4) Blow with nitrogen gas. ※ If discolored refrigeration oil or any foreign matters is discharged by the blow, wash the pipe system or install a new pipe system.
 - For the flare nut, do not use the old one, but use the one supplied with the outdoor unit. Process a flare to the dimensions specified for R410A.
 - Turn on-site setting switch SW5-1 to the ON position. (Where the gas pipe size is φ 19.05)

<Where the existing unit cannot be run for a cooling operation.>

- Wash the pipe system or install a new pipe system.
- If you choose to wash the pipe system, contact our distributor in the area.

<Table of pipe size restrictions> ◎:Standard pipe size ○:Usable △:Restricted to shorter pipe length limits
Cool ↓ : Cooling capacity drop ×:Not usable

Additional charging amount of refrigerant per 1m	0.06kg/m			0.12kg/m			0.2kg/m			
	φ 9.52	φ 9.52	φ 9.52	φ 12.7	φ 12.7	φ 12.7	φ 15.88	φ 15.88	φ 15.88	
Pipe size	Liquid pipe	φ 9.52	φ 9.52	φ 9.52	φ 12.7	φ 12.7	φ 12.7	φ 15.88	φ 15.88	φ 15.88
	Gas pipe	φ 22.22	φ 25.4 ^{※2}	φ 28.6 ^{※2}	φ 22.22	φ 25.4	φ 28.6	φ 22.22	φ 25.4	φ 28.6
200V	Usability	◎	○	○	◎	△:※3	△:※3	△:※3	△:※3	×
	Maximum one-way pipe length	35	70	70	35	70	70	24	24	×
	Length covered without additional charge	30	30	30	30	15	15	9	9	×
250V	Usability	×	×	×	◎	○	△:※3	△:※3	△:※3	△:※3
	Maximum one-way pipe length	×	×	×	35	70	70	40	40	40
	Length covered without additional charge	×	×	×	30	30	25	18	18	13

※1 Because of its insufficient pressure resistance, turn the dip switch SW5-1 provided on the outdoor unit board to the ON position for φ 19.05 × 11.0.

(In the case of a twin-triple-double-twin model, this also applies to the case where φ 19.05 × 11.0 is used in a pipe system after the first branching point.

However, you need not turn the dip switch SW5-1 to the ON position, if 1/2H pipes or pipes having 1.2 or thicker walls are used.

※2 When the main pipe length exceeds 40m, a significant capacity drop may be experienced due to pressure loss in the liquid pipe system. Use φ 12.7 for the liquid main.

※3 Keep the total pipe length, not one-way pipe length, below the specified maximum pipe length.

● When refrigerant piping is shorter than 3m, reduce refrigerant by 1kg from factory charged volume and adjust to 4.4kg(Model 200V) or 6.2kg(Model 250V).

● Any combinations of pipe sizes not listed in the table or marked with × in the table are not usable.

<Pipe system after the branching pipe> ◎:Standard pipe size ○:Usable ×:Not usable — : Outside of an object

● Any combinations of pipe sizes not listed in the table or marked with × in the table are not usable.

Additional charging amount of refrigerant per 1m	0.06kg/m			0.06kg/m				
	Liquid pipe		φ 9.52	Liquid pipe		φ 9.52		
Pipe size	Gas pipe	Combination of capacity	φ 12.7	φ 15.88	φ 19.05 ^{※1}	φ 12.7	φ 15.88	φ 19.05 ^{※1}
200V	Twin	100+100	×	◎	○	—	—	—
	Triple A	71+71+71	×	◎	○	—	—	—
	Triple B	71+71+71	×	◎	※5	×	—	○
	Double twin	50+50+50+50	×	◎	○	◎	○	×
	Twin	125+125	×	◎	○	—	—	—
250V	Triple A	—	—	—	—	—	—	—
	Triple B	60+60+125	×	◎	○	◎	×	×
	Triple B	71+71+100	×	◎	※5	×	◎	×
	Double twin	60+60+60+60	×	◎	○	◎	○	×

※4 Piping size after branch should be equal or smaller than main pipe size.

※5 Piping size from first branch to indoor unit should be φ 9.52 (Liquid) / φ 15.88 (Gas).

<The model types of existing units of which branching pipes are reusable.>

Models later than Type 8.

● FDC * * * 8 □ □ □

● FDCP * * * 8 □ □ □

The branching pipes used with models other than those listed above are not reusable because of their insufficient pressure resistance. Please use our genuine branching pipes for R410A.

● * * * are numbers representing horsepower. □ □ □ is an alphanumeric letter.

Formula to calculate additional charge volume

$$\text{Additional charge volume (kg)} = \{ \text{Main pipe length (m)} - \text{Length covered without additional charge shown in the table (m)} \} \times \text{Additional charge volume per meter of pipe shown in the table (kg/m)} + \text{Total length of branch pipes (m)} \times \text{Additional charge volume per meter of pipe shown in the table (kg/m)}$$

※ If you obtain a negative figure as a result of calculation, no additional refrigerant needs to be charged.

Example When an 250V (twin installation) is installed in a 40m long existing pipe system (main pipe length 30m, liquid φ 15.88, gas φ 25.4; pipe length after branching pipe 5m x 2, liquid φ 9.52, gas φ 15.88), the quantity of refrigerant to charge additionally should be (30m-18m) x 0.2kg/m + 5m x 2 x 0.06kg/m = 3.0 kg.

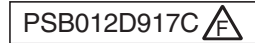

(e) Method for connecting the accessory pipe (Models FDC200,250 only)

Be sure to use the accessory pipe to connect the operation valve on the gas side with the field pipe.

- ① Referring to Table ① and Table ②, prepare the straight pipe and the elbow in the field, which are used in the construction examples (A) ~ (D) applicable to the connecting direction.
- ② Firstly, use the accessory pipe to assemble the connecting pipe assembly outside the outdoor unit.
As shown in the figures of construction examples (A) ~ (D) applicable to the connecting direction(chain double dashed line), braze the accessory pipe and the parts prepared in the above ①.
- ③ After assembly of the connecting pipe, connect it to the service valve on the gas side inside the outdoor unit.
Tighten the flare nut with appropriate torque.
- ④ After connection of the connecting pipe assembly to the service valve on the gas side, braze the connecting pipe assembly and the field pipe.

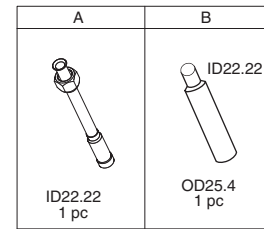

Appropriate torque	
φ 19.05	100~120N·m

Table ① Parts used for the connecting pipe assembly

No.	Name	Qty.	Remarks
1	Accessory pipe A	1	Accessories
2	Straight pipe ①	1	Procured in the field
3	Straight pipe ②	1 or 0	Procured in the field (Not required for downward direction)
4	Elbow	1 or 0	Procured in the field (Not required for downward direction)

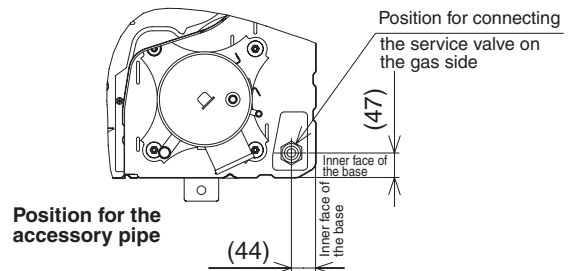

Table ② Length of the straight pipe (prepared in the field)

	Pipe size	(A) Downward	(B) Forward	(C) Rightward	(D) Backward
Straight pipe ①	φ 22.22 × t1.6	above 415mm	185~235mm	185~235mm	185~235mm
Straight pipe ②	φ 22.22 × t1.6	-	above 125mm	above 125mm	above 405mm

- Be sure to use pipes of 1/2H material, and wall thickness above 1mm. (Pressure resistance of O-type pipe is not enough)
- Switch ON SW5-1 on the control PCB, if O-type pipe must be used and bent with the bender.
During heating operation, the high-pressure protection may be actuated under the condition lower than the normal pressure, and the heating capacity may decrease.

About brazing

- **Be sure to braze while supplying nitrogen gas.**

If no nitrogen gas is supplied, a large amount of impurity (oxidized fi lm) will be generated, which may clog the capillary tube and the expansion valve, resulting in fatal malfunction.

- Branching pipe set can be used by using the accessory pipe B. When φ 22.22(OD) size of the indoor unit gas pipe is used, the accessory pipe B is unnecessary.

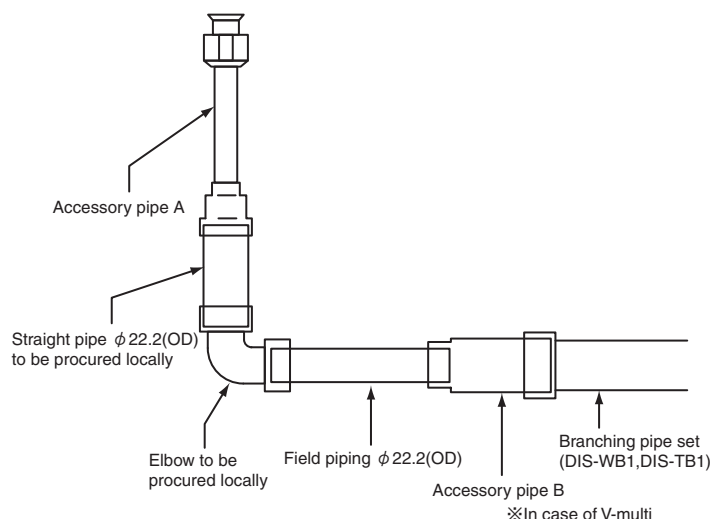

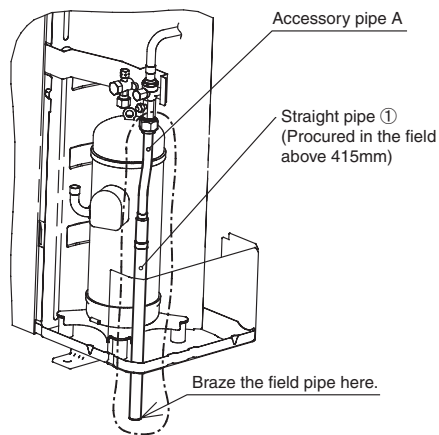

Construction example A
(Downward)

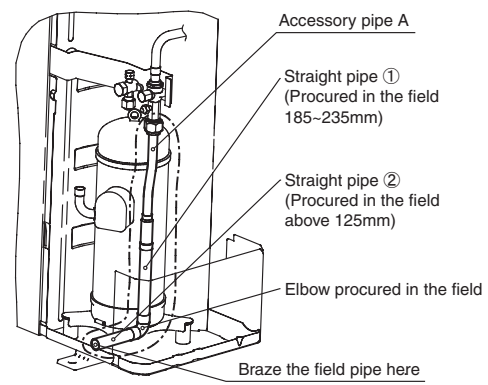

Construction example B
(Forward)

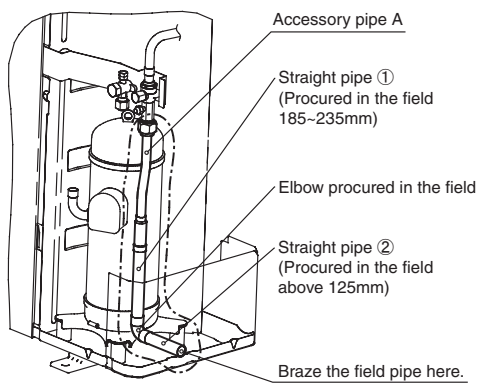

Construction example C
(Rightward)

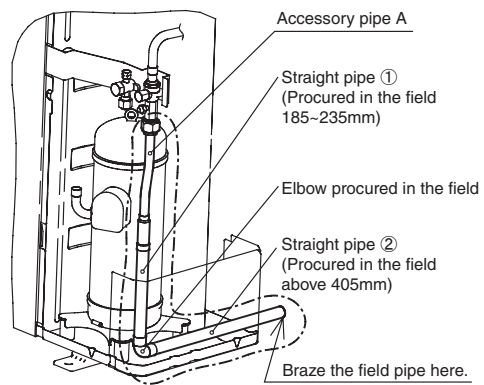

Construction example D
(Backward)

PSB012D966

(4) Electric wiring work installation

Electrical wiring work must be performed by an electrician qualified by a local power provider according to the electrical installation technical standards and interior wiring regulations applicable to the installation site.

Security instructions

- Read the "SAFETY PRECAUTIONS" carefully first of all and then strictly follow it during the installation work in order to protect yourself.
- The precautionary items mentioned below are distinguished into two levels, **⚠WARNING** and **⚠CAUTION**.
 - ⚠WARNING : Wrong installation would cause serious consequences such as injuries or death.
 - ⚠CAUTION : Wrong installation might cause serious consequences depending on circumstances.
- Both mentions the important items to protect your health and safety so strictly follow them by any means.
- The meanings of "Marks" used here are as shown on the right.
 - ⊘ Never do it under any circumstances.
 - ⊙ Always do it according to the instruction.
- Accord with following items. Otherwise, there will be the risks of electric shock and fire caused by overheating or short circuit.

⚠WARNING

- Be sure to have the electrical wiring work done by qualified electrical installer, and use exclusive circuit. ⊙
Power source with insufficient capacity and improper work can cause electric shock and fire.
- Use specified wire for electrical wiring, fasten the wiring to the terminal securely, and hold the cable securely in order not to apply unexpected stress on the terminal. ⊙
Loose connections or hold could result in abnormal heat generation or fire.
- Arrange the electrical wires in the control box properly to prevent them from rising. Fit the lid of the services panel property. ⊙
Improper fitting may cause abnormal heat and fire.
- Use the genuine optional parts. And installation should be performed by a specialist. ⊙
If you install the unit by yourself, it could cause water leakage, electric shock and fire.
- Do not repair by yourself. And consult with the dealer about repair. ⊘
Improper repair may cause water leakage, electric shock or fire.
- Consult the dealer or a specialist about removal of the air conditioner. ⊙
Improper installation may cause water leakage, electric shock or fire.
- Turn off the power source during servicing or inspection work. ⊙
If the power is supplied during servicing or inspection work, it could cause electric shock and injury by the operating fan.
- Shut off the power before electrical wiring work. ⊙
It could cause electric shock, unit failure and improper running.

⚠CAUTION

- Perform earth wiring surely. ⊙
Do not connect the earth wiring to the gas pipe, water pipe, lightning rod and telephone earth wiring. Improper earth could cause unit failure and electric shock due to a short circuit.
- Earth leakage breaker must be installed. ⊙
If the earth leakage breaker is not installed, it can cause electric shocks.
- Make sure to install earth leakage breaker on power source line. (countermeasure thing to high harmonics.) ⊙
Absence of breaker could cause electric shock.
- Use the circuit breaker of correct capacity. Circuit breaker should be the one that disconnect all poles under over current. ⊙
Using the incorrect one could cause the system failure and fire.
- Do not use any materials other than a fuse of correct capacity where a fuse should be used. ⊘
Connecting the circuit by wire or copper wire could cause unit failure and fire.
- Use power source line of correct capacity. ⊙
Using incorrect capacity one could cause electric leak, abnormal heat generation and fire.
- Do not mingle solid cord and stranded cord on power source and signal side terminal block. ⊘
In addition, do not mingle difference capacity solid or stranded cord. Inappropriate cord setting could cause losing screw on terminal block, bad electrical contact, smoke and fire.
- Do not turn off the power source immediately after stopping the operation. ⊘
Be sure to wait for more than 5 minutes. Otherwise it could cause water leakage or breakdown.
- Do not control the operation with the circuit breaker. ⊘
It could cause fire or water leakage. In addition, the fan may start operation unexpectedly and it may cause injury.

① Electrical Wiring Connection

- Use three-core cable as wiring between indoor and outdoor unit. As for detail, refer to "INSTALLATION MANUAL" of outdoor Unit.
- Set earth of D-type.
- Keep "remote controller line" and "power source line" away from each other on constructing of unit outside.
- Run the lines (power source, remote controller and "between indoor and outdoor unit") upper ceiling through iron pipe or other tube protection to avoid the damage by mouse and so on.
- Do not add cord in the middle of line route (of power source, remote controller and "between indoor and outdoor unit") on outside of unit. If connecting point is flooded, it could cause problem as for electric or communication. (In the case that it is necessary to set connecting point on the way, perform thorough waterproof measurement.)
- Do not connect the power source line [220V/240V/380V/415V] to signal side terminal block. Otherwise, it could cause failure.
- Screw the line to terminal block without any looseness, certainly.
- Do not turn on the switch of power source, before all of line work is done.
- Connection of the line ("Between indoor and outdoor unit", Earth and Remote controller)
- ① Remove lid of control box before connect the above lines, and connect the lines to terminal block according to number pointed on label of terminal block.
In addition, pay enough attention to confirm the number to lines, because there is electrical polarity except earth line. Furthermore, connect earth line to earth position of terminal block of power source.
- ② Install earth leakage breaker on power source line. In addition, select the type of breaker for inverter circuit as earth leakage breaker.
- ③ If the function of selected earth leakage breaker is only for earth-fault protection, hand switch (switch itself and type "B" fuse) or circuit breaker is required in series with the earth leakage breaker.
- ④ Install isolator or disconnect switch on the power supply wiring in accordance with the local codes and regulations.
The isolator should be set in the box with key to prevent touching by another person when servicing.

Cable connection for single unit installation

- ① As for connecting method of power source, select from following connecting patterns. In principle, do not directly connect power source line to inside unit.
 - ※ As for exceptional connecting method of power source, discuss with the power provider of the country with referring to technical documents, and follow its instruction.
- ② For cable size and circuit breaker selection, refer to the outdoor unit installation manual.

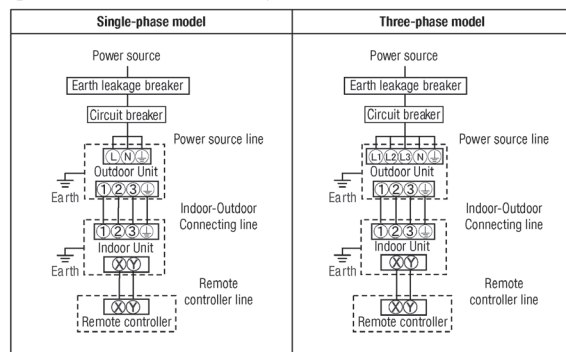

Cable connection for a V multi configuration installation

- ① Connect the same pairs number of terminal block "①, ②, and ③" and "⊗ and ⊙" between master and slave indoor units.
- ② Do the same address setting of all inside units belong to same refrigerant system by rotary switch SW2 on indoor unit's PCB (Printed circuit board).
- ③ Set slave indoor unit as "slave 1" through "slave 3" by address switch SW5-1, 5-2 on PCB.
- ④ When the [AIR CON NO.] button on the remote control unit is pressed after turning on the power, an indoor unit's address number will be displayed. Do not fail to confirm that the connected indoor unit's numbers are displayed on the remote control unit by pressing the ▲ or ▼ button.

Method of setting Master/Slave of indoor unit
(Factory setting: "Master")

		Master	Slave 1	Slave 2	Slave 3
PCB SW	SW5-1	OFF	OFF	ON	ON
	SW5-2	OFF	ON	OFF	ON

② Remote Control, Wiring and functions

● DO NOT install it on the following places

- ① Places exposed to direct sunlight
- ② Places near heat devices
- ③ High humidity places
- ④ Hot surface or cold surface enough to generate condensation
- ⑤ Places exposed to oil mist or steam directly.
- ⑥ Uneven surface

Installation and wiring of remote controller

- ① Install remote controller referring to the attached installation manual.
- ② Wiring of remote controller should use 0.3mm² × 2 core wires or cables.

The insulation thickness is 1mm or more. (on-site configuration)

- ③ Maximum prolongation of remote control wiring is 600 m.

If the prolongation is over 100m, change to the size below.

But, wiring in the remote controller case should be under 0.5mm². Change the wire size outside of the case according to wire connecting. Waterproof treatment is necessary at the wire connecting section. Be careful about contact failure.

- 100 - 200m 0.5mm² × 2 cores
- Under 300m 0.75mm² × 2 cores
- Under 400m 1.25mm² × 2 cores
- Under 600m 2.0mm² × 2 cores

- ④ Avoid using multi-core cables to prevent malfunction.
- ⑤ Keep remote controller line away from earth (frame or any metal of building).
- ⑥ Make sure to connect remote controller line to the remote controller and terminal block of indoor unit. (No polarity)

Control plural indoor units by a single remote controller.

- ① A remote controller can control plural indoor units (Up to 16).
- In above setting, all plural indoor units will operate under same mode and temperature setting.
- ② Connect all indoor units with 2 core remote controller line.
- ③ Set unique remote control communication address from "0" to "F" to each inside unit by the rotary switch SW2 on the indoor unit's PCB.

After a unit is energized, it is possible to display an indoor unit address by pressing AIR CON NO. button on the remote control unit. Press the ▲ or ▼ button to make sure that all indoor units connected are displayed in order.

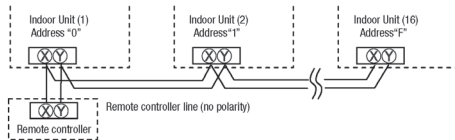

Confirming method of indoor units

When indoor unit address number is displayed on remote controller, pushing the (MODE) button to make the indoor unit with that number blow air (Display example: "I/U001"). Push the (MODE) button again to stop the operation. However, this operation is invalid on the air-conditioning running.

Master/ slave setting when more than one remote control unit are used

A maximum of two remote control units can be connected to one indoor unit (or one group of indoor units.)
 The air conditioner operation follows the last operation of the remote controller regardless of the master/slave setting of it.
 Acceptable combination is "two (2) wired remote controllers", "one (1) wired remote controller and one (1) wireless kit" or "two (2) wireless kits".
 Set SW1 (wired remote controller) or SW1-2 (wireless kit) to "Slave" for the slave remote control unit. It was factory set to "Master" for shipment.
 Note: The setting "Remote control unit sensor enabled" is only selectable with the master remote control unit in the position where you want to check room temperature.

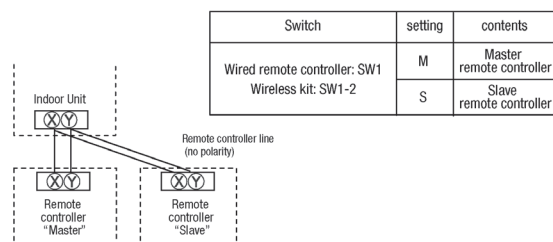

③ Trial operation

The method of trial cooling operation

Operate the remote control unit as follows.

1. Starting a cooling test run.
 - ① Start the system by pressing the (ON/OFF) button.
 - ② Select "Cool" with the (MODE) button.
 - ③ Press the (TEST) button for 3 seconds or longer.
The screen display will switch to: "TEST RUN"
 - ④ When the (SET) button is pressed while "TEST RUN" is indicated, a cooling test run will start.
The screen display will switch to: "TEST RUN".
2. Ending a cooling test run.
Pressing the (ON/OFF) button, the (TEMP) button or (MODE) button will end a cooling test run. (Cooling test run will end after 30 minutes pass.)
"TEST RUN" shown on the screen will go off.

Checking operation data

Operation data can be checked with remote control unit operation.

1. Press the (CHECK) button.
The display change "OPER DATA"
2. Press the (SET) button while "OPER DATA" is displayed.
3. When only one indoor unit is connected to remote controller, "DATA LOADING" is displayed (blinking indication during data loading).

Next, operation data of the indoor unit will be displayed. Skip to step 7.

4. When plural indoor units is connected, the smallest address number of indoor unit among all connected indoor unit is displayed.

[Example]:

"SELECT I/U" (blinking 1 seconds) → "I/U000" (blinking)

5. Select the indoor unit number you would like to have data displayed with the (▲) (▼) button.
6. Determine the indoor unit number with the (SET) button.

(The indoor unit number changes from blinking indication to continuous indication) "I/U000" (The address of selected indoor unit is blinking for 2 seconds.)

"DATA LOADING" (A blinking indication appears while data loaded.)

Next, the operation data of the indoor unit is indicated.

7. Upon operation of the (▲) (▼) button, the current operation data is displayed in order from data number 01.
The items displayed are in the above table.
※ Depending on models, the items that do not have corresponding data are not displayed.
 8. To display the data of a different indoor unit, press the (AIR CON NO.) button, which allows you to go back to the indoor unit selection screen.
 9. Pressing the (ON/OFF) button will stop displaying data.
Pressing the (RESET) button during remote control unit operation will undo your last operation and allow you to go back to the previous screen.
- Ⓜ If two (2) remote controllers are connected to one (1) inside unit, only the master controller is available for trial operation and confirmation of operation data. (The slave remote controller is not available.)

Trail operation of drain pump

Drain pump operation from remote control unit is possible. Operate a remote control unit by following the steps described below.

1. To start a forced drain pump operation.
 - ① Press the (TEST) button for three seconds or longer.
The display will change "TEST RUN"
 - ② Press the (▼) button once and cause "DRAIN PUMP" to be displayed.
 - ③ When the (SET) button is pressed, a drain pump operation will start.
Display: "TO STOP"
2. To cancel a drain pump operation.
 - ① If either (SET) or (ON/OFF) button is pressed, a forced drain pump operation will stop. The air conditioning system will become OFF.

Ⓜ If two (2) remote controllers are connected to one (1) inside unit, only the master controller is available for trial operation and confirmation of operation data. (The slave remote controller is not available.)

Number	Data Item
01	(Operation Mode)
02	SET TEMP (Set Temperature)
03	RETURN AIR (Return Air Temperature)
04	SENSOR (Remote Controller Thermistor Temperature)
05	TH-R1 (Indoor Unit Heat Exchanger Thermistor / U Bend)
06	TH-R2 (Indoor Unit Heat Exchanger Thermistor / Capillary)
07	TH-R3 (Indoor Unit Heat Exchanger Thermistor / Gas Header)
08	I/U FANSPEED (Indoor Unit Fan Speed)
09	DEMAND Hz (Frequency Requirements)
10	ANSWER Hz (Response Frequency)
11	I/U EEV P (Pulse of Indoor Unit Expansion Valve)
12	TOTAL I/U RUN H (Total Running Hours of The Indoor Unit)
21	OUTDOOR (Outdoor Air Temperature)
22	THO-R1 (Outdoor Unit Heat Exchanger Thermistor)
23	THO-R2 (Outdoor Unit Heat Exchanger Thermistor)
24	COMP Hz (Compressor Frequency)
25	HP MPa (High Pressure)
26	LP MPa (Low Pressure)
27	Td (Discharge Pipe Temperature)
28	COMP BOTTOM (Comp Bottom Temperature)
29	CT AMP (Current)
30	TARGET SH (Target Super Heat)
31	SH (Super Heat)
32	TOSH (Discharge Pipe Super Heat)
33	PROTECTION No. (Protection State No. of The Compressor)
34	O/U FANSPEED (Outdoor Unit Fan Speed)
35	63HT (63HT On/Off)
36	DEFROST (Defrost Control On/Off)
37	TOTAL COMP RUN H (Total Running Hours of The Compressor)
38	O/U EEV1 P (Pulse of The Outdoor Unit Expansion Valve EEV1)
39	O/U EEV2 P (Pulse of The Outdoor Unit Expansion Valve EEV2)

※ Depending on outdoor unit model, there are data not shown.

④ Function Setting by Remote Controller

The functional setting

● The initial function setting for typical using is performed automatically for a remote control unit and an indoor unit by the door unit connected, when remote controller and inside unit are connected.

As long as they are used in a typical manner, there will be no need to change the initial settings.
If you would like to change the initial setting marked "○", set your desired setting as for the selected item.
The procedure of functional setting is shown as the following diagram.
As for detail of setting, refer to the installation manual of remote controller.

[Flow of function setting]

Start : While indoor unit do not operate, press "○" (SET) and "◀▶" (MODE) button for 3 seconds at the same time.

Finalize : Press "○" (SET) button.

Reset : Press "⊗" (RESET) button.

Select : Press ▲▼ button.

End : Press ON/OFF button.

It is possible to finish above setting on the way, and unfinished change of setting is unavailable.

"○" : Initial settings

"⊗" : Automatic criterion

As for detail, refer to the installation manual of remote controller.

During air-conditioner stopping push
○ (SET) + ◀▶ (MODE) button
simultaneously for 3 seconds

Consult the technical data etc for each control details

Record and save the
setting

FUNCTION SET ▼																	
FUNCTION ▼ (Remote controller function)																	
Function	setting																
01 BRILLE F4 SET	<table border="1"> <tr><td>14 INVALID</td><td>○</td></tr> <tr><td>50Hz ZONE ONLY</td><td>○</td></tr> <tr><td>60Hz ZONE ONLY</td><td>○</td></tr> </table> <p>When you use at 50Hz area When you use at 60Hz area</p>	14 INVALID	○	50Hz ZONE ONLY	○	60Hz ZONE ONLY	○										
14 INVALID	○																
50Hz ZONE ONLY	○																
60Hz ZONE ONLY	○																
02 AUTO RUN SET	<table border="1"> <tr><td>AUTO RUN ON</td><td>⊗</td></tr> <tr><td>AUTO RUN OFF</td><td>⊗</td></tr> </table> <p>Automatic operation is impossible</p>	AUTO RUN ON	⊗	AUTO RUN OFF	⊗												
AUTO RUN ON	⊗																
AUTO RUN OFF	⊗																
03 SENS TEMP SW	<table border="1"> <tr><td>SENS TEMP VALID</td><td>○</td></tr> <tr><td>SENS TEMP INVALID</td><td>○</td></tr> </table> <p>Temperature setting button is not working</p>	SENS TEMP VALID	○	SENS TEMP INVALID	○												
SENS TEMP VALID	○																
SENS TEMP INVALID	○																
04 MODE SW	<table border="1"> <tr><td>MODE VALID</td><td>○</td></tr> <tr><td>MODE INVALID</td><td>○</td></tr> </table> <p>Mode button is not working</p>	MODE VALID	○	MODE INVALID	○												
MODE VALID	○																
MODE INVALID	○																
05 ON/OFF SW	<table border="1"> <tr><td>ON/OFF VALID</td><td>○</td></tr> <tr><td>ON/OFF INVALID</td><td>○</td></tr> </table> <p>On/Off button is not working</p>	ON/OFF VALID	○	ON/OFF INVALID	○												
ON/OFF VALID	○																
ON/OFF INVALID	○																
06 FAN SPEED SW	<table border="1"> <tr><td>FAN SPEED VALID</td><td>⊗</td></tr> <tr><td>FAN SPEED INVALID</td><td>⊗</td></tr> </table> <p>Fan speed button is not working</p>	FAN SPEED VALID	⊗	FAN SPEED INVALID	⊗												
FAN SPEED VALID	⊗																
FAN SPEED INVALID	⊗																
07 LOUVER SW	<table border="1"> <tr><td>LOUVER VALID</td><td>⊗</td></tr> <tr><td>LOUVER INVALID</td><td>⊗</td></tr> </table> <p>Louver button is not working</p>	LOUVER VALID	⊗	LOUVER INVALID	⊗												
LOUVER VALID	⊗																
LOUVER INVALID	⊗																
08 TIMER SW	<table border="1"> <tr><td>TIMER VALID</td><td>○</td></tr> <tr><td>TIMER INVALID</td><td>○</td></tr> </table> <p>Timer button is not working</p>	TIMER VALID	○	TIMER INVALID	○												
TIMER VALID	○																
TIMER INVALID	○																
09 SENSOR SET	<table border="1"> <tr><td>SENSOR OFF</td><td>○</td></tr> <tr><td>SENSOR ON</td><td>○</td></tr> <tr><td>SENSOR +3.0°C</td><td>○</td></tr> <tr><td>SENSOR +2.0°C</td><td>○</td></tr> <tr><td>SENSOR +1.0°C</td><td>○</td></tr> <tr><td>SENSOR -1.0°C</td><td>○</td></tr> <tr><td>SENSOR -2.0°C</td><td>○</td></tr> <tr><td>SENSOR -3.0°C</td><td>○</td></tr> </table> <p>Remote thermistor is not working. Remote thermistor is working. Remote thermistor is working, and to be set for producing +3.0°C increase in temperature. Remote thermistor is working, and to be set for producing +2.0°C increase in temperature. Remote thermistor is working, and to be set for producing +1.0°C increase in temperature. Remote thermistor is working, and to be set for producing -1.0°C increase in temperature. Remote thermistor is working, and to be set for producing -2.0°C increase in temperature. Remote thermistor is working, and to be set for producing -3.0°C increase in temperature.</p>	SENSOR OFF	○	SENSOR ON	○	SENSOR +3.0°C	○	SENSOR +2.0°C	○	SENSOR +1.0°C	○	SENSOR -1.0°C	○	SENSOR -2.0°C	○	SENSOR -3.0°C	○
SENSOR OFF	○																
SENSOR ON	○																
SENSOR +3.0°C	○																
SENSOR +2.0°C	○																
SENSOR +1.0°C	○																
SENSOR -1.0°C	○																
SENSOR -2.0°C	○																
SENSOR -3.0°C	○																
10 AUTO RESTART	<table border="1"> <tr><td>INVALID</td><td>○</td></tr> <tr><td>VALID</td><td>○</td></tr> </table>	INVALID	○	VALID	○												
INVALID	○																
VALID	○																
11 VENT LINK SET	<table border="1"> <tr><td>NO VENT</td><td>○</td></tr> <tr><td>VENT LINK</td><td>○</td></tr> <tr><td>NO VENT LINK</td><td>○</td></tr> </table> <p>Connect the Single split series and the VRF series to the indoor board CNT and indoor board CND respectively. If a ventilation device is connected, been geared with the motion of indoor device, the ventilation device is operated/stopped. By connecting the ventilation device with the Single split series device to indoor board CNT, the VRF series device to CND, you can operate/stop the ventilation device independently by the handling of ventilation button.</p>	NO VENT	○	VENT LINK	○	NO VENT LINK	○										
NO VENT	○																
VENT LINK	○																
NO VENT LINK	○																
12 TEMP RANGE SET	<table border="1"> <tr><td>INDIC CHANGE</td><td>○</td></tr> <tr><td>NO INDIC CHANGE</td><td>○</td></tr> </table> <p>If you change the range of set temperature, the indication of set temperature will vary following the control. If you change the range of set temperature, the indication of set temperature will not vary following the control, and keep the set temperature.</p>	INDIC CHANGE	○	NO INDIC CHANGE	○												
INDIC CHANGE	○																
NO INDIC CHANGE	○																
13 FAN	<table border="1"> <tr><td>HI-MID-LO</td><td>⊗</td></tr> <tr><td>HI-LO</td><td>⊗</td></tr> <tr><td>HI-MID</td><td>⊗</td></tr> <tr><td>1 FAN SPEED</td><td>⊗</td></tr> </table> <p>Airflow of fan becomes HI-MID-LO or the four speed of HI-MID-LO. Airflow of fan becomes HI-LO. Airflow of fan becomes HI-MID. Airflow of fan is fixed at one speed.</p>	HI-MID-LO	⊗	HI-LO	⊗	HI-MID	⊗	1 FAN SPEED	⊗								
HI-MID-LO	⊗																
HI-LO	⊗																
HI-MID	⊗																
1 FAN SPEED	⊗																
14 POSITION	<table border="1"> <tr><td>POSITION STOP</td><td>○</td></tr> <tr><td>FREE STOP</td><td>○</td></tr> </table> <p>If you want to change the remote control function "14 POSITION", You must change the indoor function "04 POSITION" accordingly. You can select the louver stop position in the four. The louver can stop at any position.</p>	POSITION STOP	○	FREE STOP	○												
POSITION STOP	○																
FREE STOP	○																
15 MODEL TYPE	<table border="1"> <tr><td>HEAT PUMP</td><td>⊗</td></tr> <tr><td>COOLING ONLY</td><td>⊗</td></tr> </table>	HEAT PUMP	⊗	COOLING ONLY	⊗												
HEAT PUMP	⊗																
COOLING ONLY	⊗																
16 EXTERNAL CONTROL SET	<table border="1"> <tr><td>INDIVIDUAL</td><td>○</td></tr> <tr><td>FOR ALL UNITS</td><td>○</td></tr> </table> <p>If you input into the indoor printed circuit board CNT from outside, the indoor device will be operated independently following the input from outside. If you input into indoor printed circuit board CNT from outside, All units which share the same one remote control network work following the input from outside.</p>	INDIVIDUAL	○	FOR ALL UNITS	○												
INDIVIDUAL	○																
FOR ALL UNITS	○																
17 ROOM TEMP INDICATION SET	<table border="1"> <tr><td>INDICATION OFF</td><td>○</td></tr> <tr><td>INDICATION ON</td><td>○</td></tr> </table> <p>In normal working indication, indoor unit temperature is indicated instead of airflow. (Only the master remote control can be indicated.)</p>	INDICATION OFF	○	INDICATION ON	○												
INDICATION OFF	○																
INDICATION ON	○																
18 INDICATION	<table border="1"> <tr><td>INDICATION ON</td><td>○</td></tr> <tr><td>INDICATION OFF</td><td>○</td></tr> </table> <p>Heating preparation indication should not be indicated.</p>	INDICATION ON	○	INDICATION OFF	○												
INDICATION ON	○																
INDICATION OFF	○																
19 °/°F SET	<table border="1"> <tr><td>°</td><td>○</td></tr> <tr><td>°F</td><td>○</td></tr> </table> <p>Temperature indication is by degree C Temperature indication is by degree F</p>	°	○	°F	○												
°	○																
°F	○																

ON/OFF button (finished)

Note 1: The initial setting marked "※" is decided by connected indoor and outdoor unit, and is automatically defined as following table.

Function No.	Item	Default	Model
Function 02 of remote controller	AUTO RUN SET	AUTO RUN ON	"Auto-RUN" mode selectable indoor unit.
		AUTO RUN OFF	Indoor unit without "Auto-RUN" mode
Function 06 of remote controller	FAN SPEED SW	INVALID	Indoor unit with two or three step of air flow setting
		INVALID	Indoor unit with only one of air flow setting
Function 07 of remote controller	LOUVER SW	VALID	Indoor unit with automatically swing louver
		INVALID	Indoor unit without automatically swing louver
Function 13 of remote controller	I/O FAN	HI-MID-LO	Indoor unit with three step of air flow setting
		HI-LO	Indoor unit with two step of air flow setting
		HI-MID	Indoor unit with only one of air flow setting
		1 FAN SPEED	Indoor unit with only one of air flow setting
Function 15 of remote controller	MODEL TYPE	HEAT PUMP	Heat pump unite
		COOLING ONLY	Exclusive cooling unite

Note 2: Fan setting of "HIGH SPEED"

Fan tap	Indoor unit air flow setting					
	PHI - Hi - Me - Lo	Hi - Me - Lo	Hi - Lo	Hi - Me	PHI - Hi	PHI - Me
FAN SPEED SET	STANDARD	PHI - Hi - Me - Lo	Hi - Me - Lo	Hi - Lo	Hi - Me	PHI - Hi
	HIGH SPEED1, 2	PHI - PHI - Hi - Me	PHI - Hi - Me	PHI - Me	PHI - Hi	PHI - Me

Initial function setting of some indoor unit is "HIGH SPEED"

4 speed is not able to be set with wireless remote controls or simple remote control (RCH-H3).

Note 3: As for plural indoor unit, set indoor functions to each master and slave indoor unit.

But only master indoor unit is received the setting change of indoor unit function "05 EXTERNAL INPUT" and "06 PERMISSION / PROHIBITION".

Only when plural indoor units are connected
Indoor No. selection

(Indoor unit function) L/U FUNCTION ▲

(Note3)

Function setting

If to change re-set with other indoor unit, push [AIRCON NO.] button, and indoor selection indication (for example: I/U 000) is set back.

02 FAN SPEED SET	STANDARD	○
	HIGH SPEED 1	
	HIGH SPEED 2	
03 FILTER SIGN SET	INDICATION OFF	
	TYPE 1	
	TYPE 2	
	TYPE 3	
	TYPE 4	
04 POSITION	4 POSITION STOP	○
	FREE STOP	
05 EXTERNAL INPUT	LEVEL INPUT	○
	PULSE INPUT	
06 PERMISSION/PROHIBITION	INVALID	○
	VALID	
07 EMERGENCY STOP	INVALID	○
	VALID	
08 SP OFFSET	OFFSET +3.0℃	
	OFFSET +2.0℃	
	OFFSET +1.0℃	
	NO OFFSET	○
09 RETURN AIR TEMP	OFFSET +2.0℃	
	OFFSET +1.5℃	
	OFFSET +1.0℃	
	NO OFFSET	○
10 FAN CONTROL	LOW FAN SPEED	○
	SET FAN SPEED	
	INTERMITTENCE	
	FAN OFF	
11 FROST PREVENTION TEMP	TEMP HIGH	
	TEMP LOW	○
12 FROST PREVENTION CONTROL	FAN CONTROL ON	○
	FAN CONTROL OFF	
13 DRAIN PUMP LINK	○	○
	○ AND ※	
	○ AND ※ AND ※	
	○ AND ※	
14 FAN REMAINING	NO REMAINING	○
	0.5 HOUR	
	1 HOUR	
	6 HOUR	
15 FAN REMAINING	NO REMAINING	○
	0.5 HOUR	
	2 HOUR	
	6 HOUR	
16 FAN INTERMITTENCE	NO REMAINING	○
	20minOFF 5minON	
	5minOFF 5minON	

(Note2)

The filter sign is indicated after running for 180 hours.
The filter sign is indicated after running for 600 hours.
The filter sign is indicated after running for 1000 hours.
The filter sign is indicated after running for 1000 hours, then it will be stopped by compulsion after 24 hours.

If to change the indoor function "04 POSITION",
The remote control function "14 POSITION" should be changed accordingly.
Select the louver stop position in four.
The louver can stop at any position.

Make permission/prohibition control of function be in effect.

With the VRF series, it is used to stop all indoor units connected with the same outdoor unit immediately.
When stop signal is inputted from remote on-off terminal "CNT-6", all indoor units are stopped immediately.

To be reset for producing +3.0°C increase in temperature during heating.
To be reset for producing +2.0°C increase in temperature during heating.
To be reset for producing +1.0°C increase in temperature during heating.

To be reset producing +2.0°C increase in return air temperature of indoor unit.
To be reset producing +1.5°C increase in return air temperature of indoor unit.
To be reset producing +1.0°C increase in return air temperature of indoor unit.
To be reset producing -1.0°C increase in return air temperature of indoor unit.
To be reset producing -1.5°C increase in return air temperature of indoor unit.
To be reset producing -2.0°C increase in return air temperature of indoor unit.

When heating thermostat is off, to be operated with low fan speed.(or with ultra low fan speed in case of some models)
When heating thermostat is off, to be operated with set fan speed.

When heating thermostat is off, to be operated intermittently.
When heating thermostat is off, the fan stops.
When the remote thermistor is working, "FAN OFF" is set automatically.
Do not set when the indoor unit's thermistor is working.

Change of indoor heat exchanger temperature to start frost prevention control.

Working only with the single split series.
To control frost prevention, the indoor fan tap is raised.

Drain pump is on during cooling and dry.
Drain pump is on during cooling, dry and heating.
Drain pump is on during cooling, dry, heating and fan.
Drain pump is on during cooling, dry and fan.

After cooling is stopped, the fan does not perform extra operation.
After cooling is stopped, the fan perform extra operation for half an hour.
After cooling is stopped, the fan perform extra operation for an hour.
After cooling is stopped, the fan perform extra operation for six hours.

After heating is stopped or heating thermostat is off, the fan does not perform extra operation.
After heating is stopped or heating thermostat is off, the fan perform extra operation for half an hour.
After heating is stopped or heating thermostat is off, the fan perform extra operation for two hours.
After heating is stopped or heating thermostat is off, the fan perform extra operation for six hours.

During heating is stopped or heating thermostat is off, the fan perform intermittent operation for five minutes after twenty minutes' off with low airflow.
During heating is stopped or heating thermostat is off, the fan perform intermittent operation for five minutes after five minutes' off with low airflow.

⑤ Control mode switching

● The control content of indoor units can be switched in following way. (is the default setting)

Switch No.	Control Content	
SW2	Indoor unit address (0-Fh)	
SW5-1	Master/Slave Switching (plural /Slave unit Setting)	
SW5-2		
SW6-1~4	Model capacity setting	
SW7-1	ON	Operation check, Drain motor test run
	OFF	Normal operation

⑥ Function of CNT connector of indoor printed circuit board

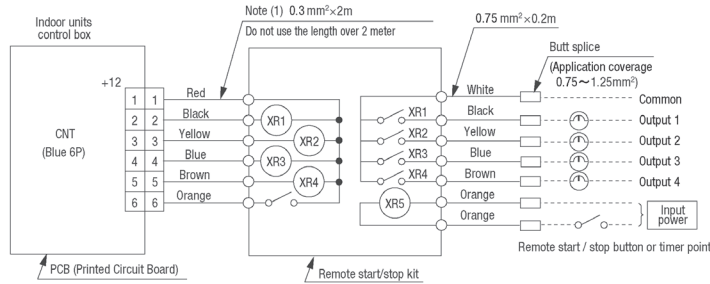

● CNT connector (local) vendor model
 Connector : Made by molex 5264 - 06
 Terminals : Made by molex 5263T

● Function

Output 1	Operation output (there is output when unit is in operation.)
Output 2	Heating output (there is output when operation MODE is HEATING.)
Output 3	Compressor ON output (there is output when compressor is in operation.)
Output 4	Inspection output (there is output when unit is stopped by error.)
Input 5	Remote operation input (Volt-free contact) (Inputted to operate unit)

⑦ Troubleshooting

The operation data is saved when the situation of abnormal operation happen, and the data can be confirmed by remote controller.

[Operating procedure]

- Press the **CHECK** button.
The display change "OPER DATA" ▼
- Once, press the ▼ button, and the display change "ERROR DATA" ▲.
- Press the **SET** button and abnormal operation data mode is started.
- When only one indoor unit is connected to remote controller, following is displayed.
 - The case that there is history of abnormal operation.
→ Error code and "DATA LOADING" is displayed.
[Example]: [E8] (ERROR CODE)
"DATA LOADING" is displayed (blinking indication during data loading).
Next, the abnormal operation data of the indoor unit will be displayed.
Skip to step 8.
 - The case that there is not history of abnormal operation.
→ "NO ERROR" is displayed for 3 seconds and this mode is closed.
- When plural indoor units is connected, following is displayed.
 - The case that there is history of abnormal operation.
→ Error code and the smallest address number of indoor unit among all connected indoor unit is displayed.
[Example]: [E8] (ERROR CODE)
"I/U000" ▲ "blinking"
 - The case that there is not history of abnormal operation.
→ Only address number is displayed.
- Select the indoor unit number you would like to have data displayed with the ▲ ▼ button.
- Determine the indoor unit number with the **SET** button.
[Example]: [E8] (ERROR CODE)
"I/U000" ▲ " (The address of selected indoor unit is blinking for 2 seconds.)
↓
[E8] "DATA LOADING" (A blinking indication appears while data loaded).
Next, the abnormal operation data is indicated.
If the indoor unit doing normal operation is selected, "NO ERROR" is displayed for 3 seconds and address of indoor unit is displayed.
- By the ▲ ▼ button, the abnormal operation data is displayed.
Displayed data item is based on **Trial operation**.
※ Depending on models, the items that do not have corresponding data are not displayed.
- To display the data of a different indoor unit, press the **AIR CON No.** button, which allows you to go back to the indoor unit selection screen.
- Pressing the **ON/OFF** button will stop displaying data.

Pressing the **RESET** button during remote control unit operation will undo your last operation and allow you to go back to the previous screen.

Ⓞ If two (2) remote controllers are connected to one (1) indoor unit, only the master controller is available for trial operation and confirmation of operation data. (The slave remote controller is not available.)

Error Code of indoor unit

Display on remote controller	LED on indoor circuit board		Content
	red (checking)	green (normal)	
Off	Off	Continuous blinking	Normal
	Off	Off	Fault on power, indoor power off or lack phase
E1	Off	Continuous blinking	Fault on the transmission between indoor circuit board and remote control
	Not sure	Not sure	Indoor computer abnormal
E5	Blinking twice	Continuous blinking	Fault on outdoor-indoor transmission
E6	Blinking once	Continuous blinking	Indoor heat exchange sensor interrupted or short-circuit
E7	Blinking once	Continuous blinking	Indoor air inhaling sensor broken or short-circuit
E8	Blinking once	Continuous blinking	The temperature of heat exchange abnormal
E9	Blinking once	Continuous blinking	Fleat SW actions (only with FS)
E10	Off	Continuous blinking	Excess number of remote controller connections
E14	Blinking for three times	Continuous blinking	The communication fault for master/slave indoor units
E16	Blinking once	Continuous blinking	Fan motor abnormal
E19	Blinking once	Continuous blinking	Configuration fault on running checking model
E28	Off	Continuous blinking	Remote controller sensor interrupted
Over E30	Off	Continuous blinking	Outdoor unit checking (outdoor circuit board LED checking)

STANDARD INVERTER PACKAGED AIR CONDITIONERS



Air-Conditioning & Refrigeration Systems Headquarters
16-5, 2-chome, Kounan, Minato-ku, Tokyo, 108-8215, Japan
Fax : (03) 6716-5926

Because of our policy of continuous improvement, we reserve the right to make changes in all specifications without notice.

© Copyright MITSUBISHI HEAVY INDUSTRIES, LTD.



Большая библиотека технической документации
<http://splitoff.ru/tehn-doc.html>
каталоги, инструкции, сервисные мануалы, схемы.