

Service manual

Room Air Conditioner Split Wall-Mounted Type

GC/CU-S24HR
GC/CU-S30HR
GC/CU-S36HR

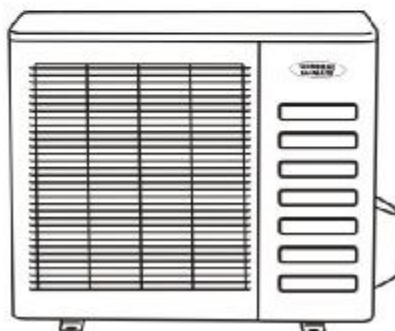
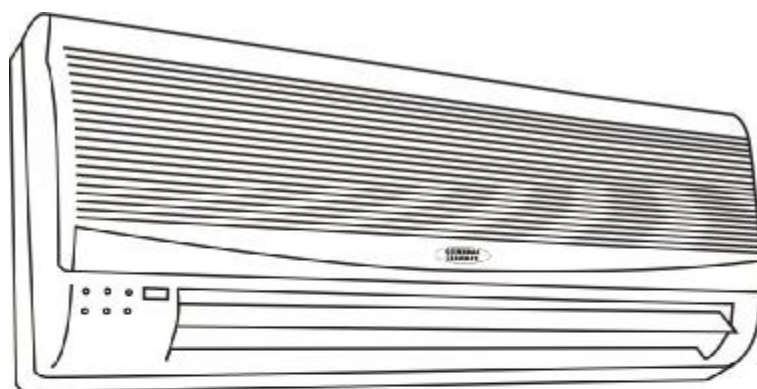

Большая библиотека технической докум
<http://splitoff.ru/tehn-doc.html>
каталоги, инструкции, сервисные мануалы

Content

1. Precaution	
1.1 Safety Precaution	1
1.2 Warning	1
2. Function	3
3. Dimension	5
3.1 Indoor unit	5
3.2 Outdoor unit	6
4. Specification	7
5. Refrigerant cycle diagram	8
6. Operation limits	9
6.1 Cooling operation	9
6.2 Heating operation	9
7. Schematic diagram and Wiring diagram	9
7.1 Schematic diagram	10
7.2 Wiring diagram	11
8. Installation details	13
8.1 Wrench torque sheet for installation	13
8.2 Connecting the cables	13
8.3 Pipe length and the elevation	13
8.4 Air purging of the piping and indoor unit	14
8.5 Pumping down (Re-installation)	15
8.6 Re-air purging (Re-installation)	16
8.7 Balance refrigerant of the 2-way, 3-way valves	17
8.8 Evacuation	18
8.9 Gas charging	19
9. Capacity table	20
9.1 GC/GU-S24HR	20
9.2 GC/GU-S30HR	21
9.3 GC/GU-S36HR	22
10. Electronic function	23
10.1 Electronic control working environment	23
10.2 Proper symbols and their meaning	23
10.3 Function	24
10.4 Protection	24
10.5 Fan only mode	24
10.6 Cooling mode	24
10.7 Dehumidifying mode	25
10.8 Heating mode	25
10.9 Defrosting mode(available for heating mode)	27
10.10 Auto mode	28
10.11 Force cooling function	28
10.12 Sleep mode	28

10.13	Auto restart function	29
11.	Model and Parameters	30
12.	Troubleshooting	31
12.1	Display board	31
12.2	Troubleshooting	32
12.3	Diagnostic chart	33
12.4	Resetting phenomenon often occurs during operation.	34
12.5	Operation lamp flashes and Timer lamp off.	34
12.6	Operation lamp flashes and Timer lamp on.	34
12.7	Operation lamp off and Timer lamp flashes	35
12.8	Operation lamp on and Timer lamp flashes	35
12.9	Operation lamp flashes, Timer lamp flashes .	35
13.	Characteristic of temperature sensor	36

1.

Precaution

1.1 Safety Precaution

- n To prevent injury to the user or other people and property damage, the following instructions must be followed.
- n Incorrect operation due to ignoring instruction will cause harm or damage.
- n Before service unit, be sure to read this service manual at first.

1.2 Warning

Ø Installation

- n **Do not use a defective or underrated circuit breaker.**
Use this appliance on a dedicated circuit.
There is risk of fire or electric shock.
- n **For electrical work, contact the dealer, seller, a qualified electrician, or an Authorized service center.**
Do not disassemble or repair the product, there is risk of fire or electric shock.
- n **Always ground the product.**
There is risk of fire or electric shock.
- n **Install the panel and the cover of control box securely.**
There is risk of fire of electric shock.
- n **Always install a dedicated circuit and breaker.**
Improper wiring or installation may cause fore or electric shock.
- n **Use the correctly rated breaker of fuse.**
There is risk of fire or electric shock.
- n **Do not modify or extend the power cable.**
There is risk of fire or electric shock.
- n **Do not install, remove, or reinstall the unit by yourself (customer).**
There is risk of fire, electric shock, explosion, or injury.
- n **Be caution when unpacking and installing the product.**
Sharp edges could cause injury, be especially careful of the case edges and the fins on the condenser and evaporator.
- n **For installation, always contact the dealer or an Authorized service center.**
There is risk of fire, electric shock, explosion, or injury.
- n **Do not install the product on a defective installation stand.**
It may cause injury, accident, or damage to the product.
- n **Be sure the installation area does not deteriorate with age.**
If the base collapses, the air conditioner could fall with it, causing property damage, product failure, and personal injury.
- n **Do not let the air conditioner run for a long time when the humidity is very high and a door or windows is left open.**
Moisture may condense and wet or damage furniture.
- n **Take care to ensure that power cable could not be pulled out or damaged during operation.**
There is risk of fire or electric shock.
- n **Do not place anything on the power cable.**
There is risk of fire or electric shock.
- n **Do not plug or unplug the power supply plug during operation.**
There is risk of fire or electric shock.
- n **Do not touch (operation) the product with wet hands.**
There is risk of fire or electric shock.
- n **Do not place a heater or other appliance near the power cable.**
There is risk of fire and electric shock.
- n **Do not allow water to run into electric parts.**
It may cause fire, failure of the product, or electric shock.
- n **Do not store or use flammable gas or combustible near the product.**
There is risk of fire or failure of product.
- n **Do not use the product in a tightly closed space for a long time.**
Oxygen deficiency could occur.
- n **When flammable gas leaks, turn off the gas and open a window for ventilation before turn the product on.**
Do not use the telephone or turn switches on or off.
There is risk of explosion or fire.
- n **If strange sounds, or small or smoke comes from product. Turn the breaker off or disconnect the power supply cable.**
There is risk of electric shock or fire.
- n **Stop operation and close the window in storm or hurricane. If possible, remove the product from the window before the hurricane arrives.**

There is risk of property damage, failure of product, or electric shock.

- n Do not open the inlet grill of the product during operation. (Do not touch the electrostatic filter, if the unit is so equipped.)**

There is risk of physical injury, electric shock, or product failure.

- n When the product is soaked (flooded or submerged), contact an Authorized service center.**

There is risk of fire or electric shock.

- n Be caution that water could not enter the product.**

There is risk of fire, electric shock, or product damage.

- n Ventilate the product from time to time when operating it together with a stove, etc.**

There is risk of fire or electric shock.

- n Turn the main power off when cleaning or maintaining the product.**

There is risk of electric shock.

- n When the product is not be used for a long time, disconnect the power supply plug or turn off the breaker.**

There is risk of product damage or failure, or unintended operation.

- n Take care to ensure that nobody could step on or fall onto the outdoor unit.**

This could result in personal injury and product damage.

Ø CAUTION

- n Always check for gas (refrigerant) leakage after installation or repair of product.**

Low refrigerant levels may cause failure of product.

- n Install the drain hose to ensure that water is drained away properly.**

A bad connection may cause water leakage.

- n Keep level even when installing the product.**

To avoid vibration of water leakage.

- n Do not install the product where the noise or hot air from the outdoor unit could damage the neighborhoods.**

It may cause a problem for your neighbors.

- n Use two or more people to lift and transport the product.**

Avoid personal injury.

- n Do not install the product where it will be exposed to sea wind (salt spray) directly.**

It may cause corrosion on the product. Corrosion, particularly on the condenser and evaporator fins, could cause product malfunction or inefficient operation.

Ø Operational

- n Do not expose the skin directly to cool air for long periods of time. (Do not sit in the draft).**

This could harm to your health.

- n Do not use the product for special purposes, such as preserving foods, works of art, etc. It is a consumer air conditioner, not a precision refrigerant system.**

There is risk of damage or loss of property.

- n Do not block the inlet or outlet of air flow.**

It may cause product failure.

- n Use a soft cloth to clean. Do not use harsh detergents, solvents, etc.**

There is risk of fire, electric shock, or damage to the plastic parts of the product.

- n Do not touch the metal parts of the product when removing the air filter. They are very sharp.**

There is risk of personal injury.

- n Do not step on or put anything on the product. (outdoor units)**

There is risk of personal injury and failure of product.

- n Always insert the filter securely. Clean the filter every two weeks or more often if necessary.**

A dirty filter reduces the efficiency of the air conditioner and could cause product malfunction or damage.

- n Do not insert hands or other object through air inlet or outlet while the product is operated.**

There are sharp and moving parts that could cause personal injury.

- n Do not drink the water drained from the product.**

It is not sanitary could cause serious health issues.

- n Use a firm stool or ladder when cleaning or maintaining the product.**

Be careful and avoid personal injury.

- n Replace the all batteries in the remote control with new ones of the same type. Do not mix old and new batteries or different types of batteries.**

There is risk of fire or explosion.

- n Do not recharge or disassemble the batteries. Do not dispose of batteries in a fire.**

They may burn or explode.

- n If the liquid from the batteries gets onto your skin or clothes, wash it well with clean water. Do not use the remote of the batteries have leaked.**

The chemical in batteries could cause burns or other health hazards.

2.

Function

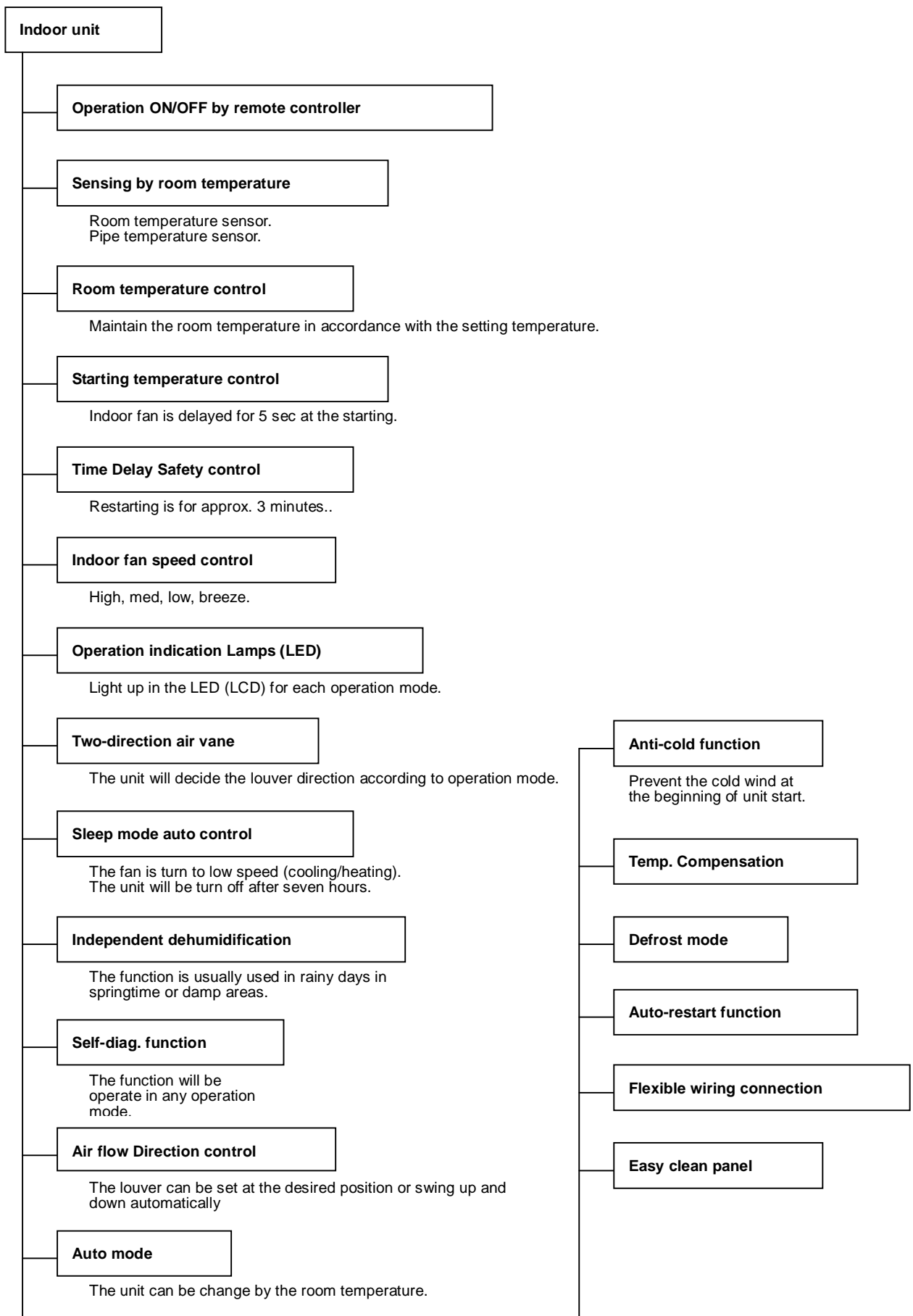

Outdoor unit

Power relay control

The unit has 3 mins delay between continuously ON/OFF operations.

Low ambient kit

The unit can operate in cooling mode at low ambient temperature conditions.

Low noise air flow system

Bird tail propeller fan makes the outdoor unit run more quietly.

Hydrophilic aluminum fin

The hydrophilic fin can improve the heating efficiency at operation mode.

4 way valve control

It is only operated in the heating operation mode except defrosting operation.

Discharge pipe temperature protect

Anti-rust cabinet

Made from electrolytic zinc steel sheet and anti-rust coated components.

Valve protection cover

It protects the valves and prevents water from dripping.

3.

Dimension

3.1 Indoor unit

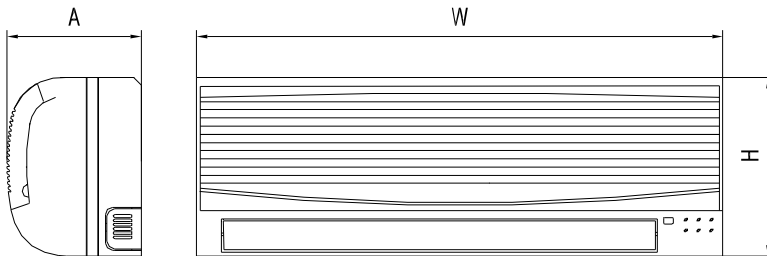

Dimension Mode	W	H	L
24K	1080	330	222
30K	1080	330	222
36K	1250	325	230

3.2 Outdoor unit

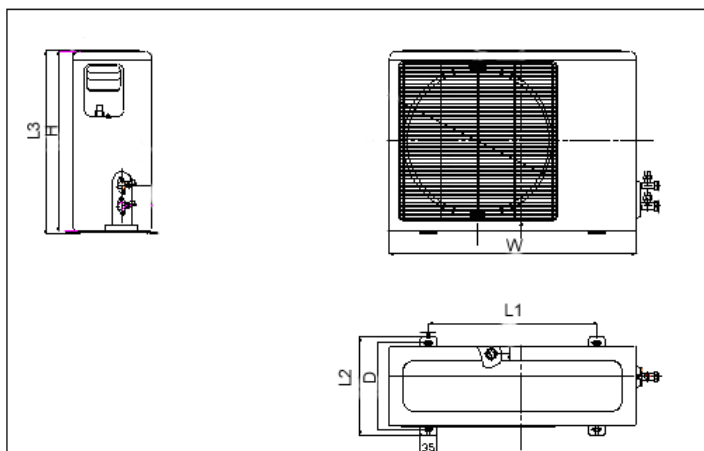

Dimension Mode	W	H	D	L1	L2	L3
24K	845	695	335	560	360	735
30K	845	695	335	560	360	735
36K	895	860	302	560	360	735

4.

Specification

Model		GC/GU-S24HR	GC/GU-S30HR	GC/GU-S36HR
Power supply		Ph-V-Hz	1, 220-240V~,50Hz	1, 220-240V~, 50Hz
Cooling	Capacity	Btu/h	24000	28000
	Input	W	2750	3200
	Rated current	A	12,5	15
	EER	Btu/w.h	8.7, 2.6	8,8
Heating	Capacity	Btu/h	27000	30000
	Input	W	2750	3100
	Rated current	A	12,5	14,5
	COP	W/W	2,9	9,7
Max. current		A	16	20
Starting current		A	50	76
Compressor	Model		QP407PT24C	ZR34KH-PFJ-522
	Type		Rotary	Scroll
	Brand		LG	Copeland
	Capacity	Btu/h	23400	28800
	Input	W	2317	2520
	Rated current(RLA)	A	10,1	12,1
	Locked rotor Amp(LRA)	A	54	76
	Thermal protector		Internal	Internal
	Capacitor	uF	45	50
Refrigerant oil	ml	650	1242	
Indoor fan motor	Model		YDK36-4G	YDK36-4G
	Brand		Welling	Welling
	Input	W	65/63/60	68/65/62
	Capacitor	uF	2 μ F/450V	3 μ F/450V
	Speed(hi/mi/lo)	r/min	1050/950/850	1150/1050/950
Indoor air flow (Hi/Mi/Lo)		m ³ /h	1050/950/850	1150/1050/950
Indoor noise level (Hi/Mi/Lo)		dB(A)	43/40/37	47/44/41
Outdoor fan motor	Model		YDK53-6K	YDK53-6K
	Brand		Welling	Welling
	Input	W	130	140
	Capacitor	uF	3,5	3,5
	Speed	r/min	800	800
Outdoor air flow		m ³ /h	2500	2500
Outdoor noise level		dB(A)	≤56	≤58
Refrigerant type R410A		g	R22/1900	R22/2450
Design pressure		MPa	2,6	2,6
Refrigerant piping	Liquid side/ Gas side	mm	φ9.53/φ16.0	φ9.53/φ16.0
	Max. refrigerant pipe length	m	20	20
	Max. difference in level	m	10	10
Operation temp		°C	17-30	17-30
Ambient temp		°C	-7 - 45	-7 - 45
Application area		m ²	40~56	50~68

Note:

The noise data is based on hemi-anechoic chamber, during actual operation; these values are normally somewhat different as a result of ambient condition.

The above design and specifications are subject to change without prior notice for product improvement.

5.

Refrigerant cycle diagram

∅ Cooling only

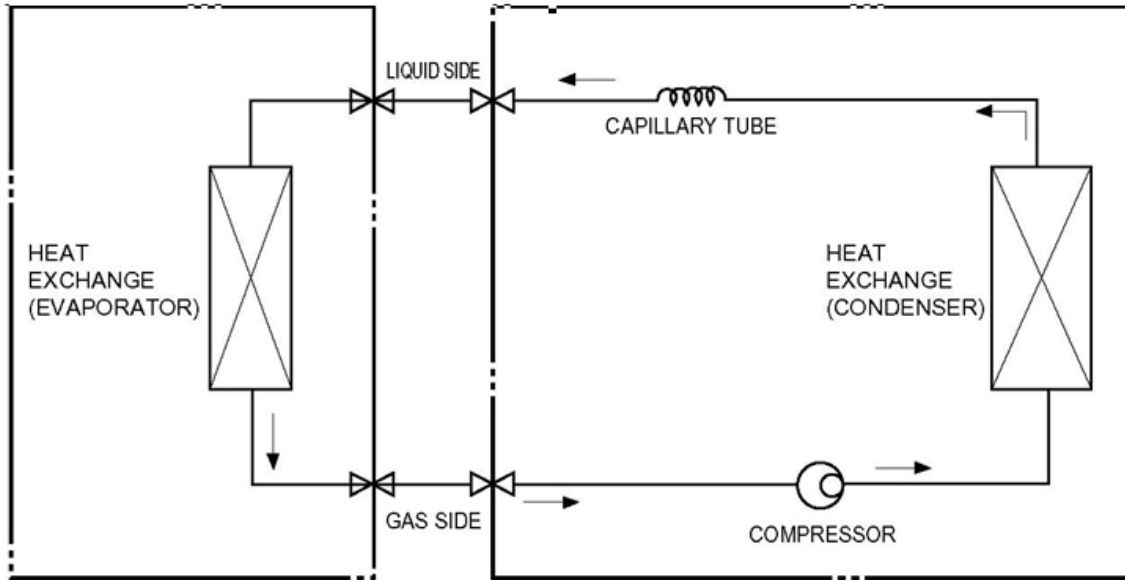

∅ Heat pump mode

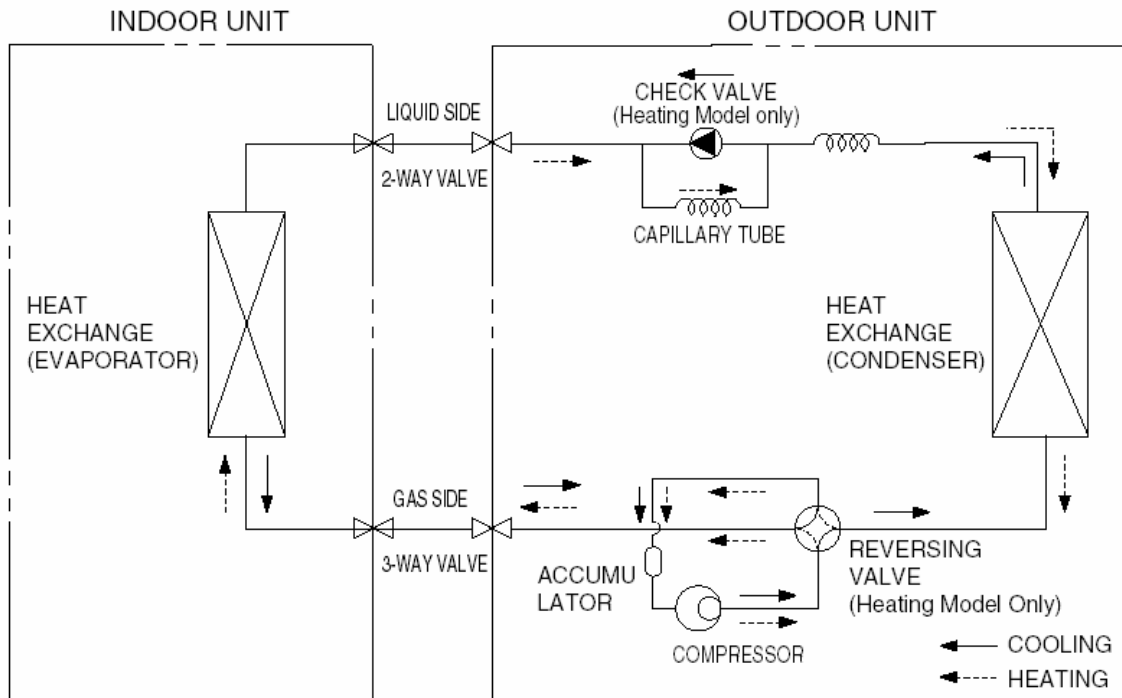

6.

Operation limits

6.1 Cooling operation

Outdoor unit air temp. °C DB

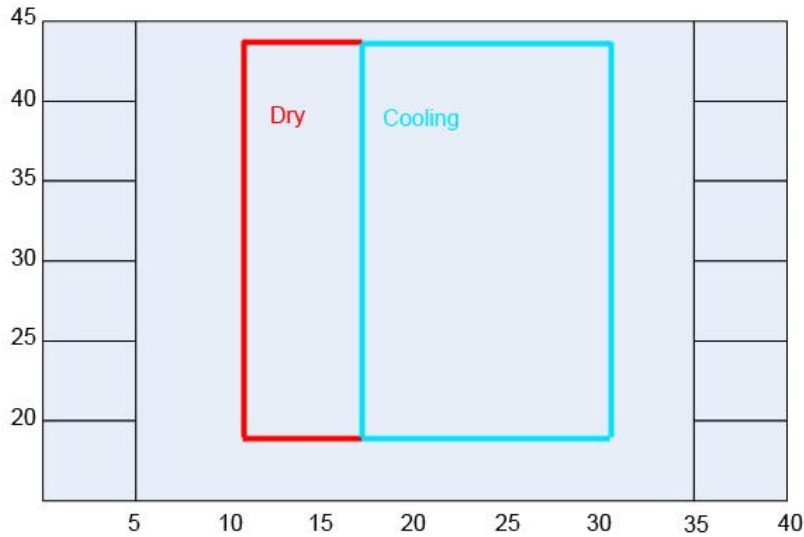

Indoor air temp. °C DB

Note: The chart is the result from the continuous operation under constant air temperature conditions. However, excludes the initial pull-down stage.

6.2 Heating operation

Indoor air temp. °C DB

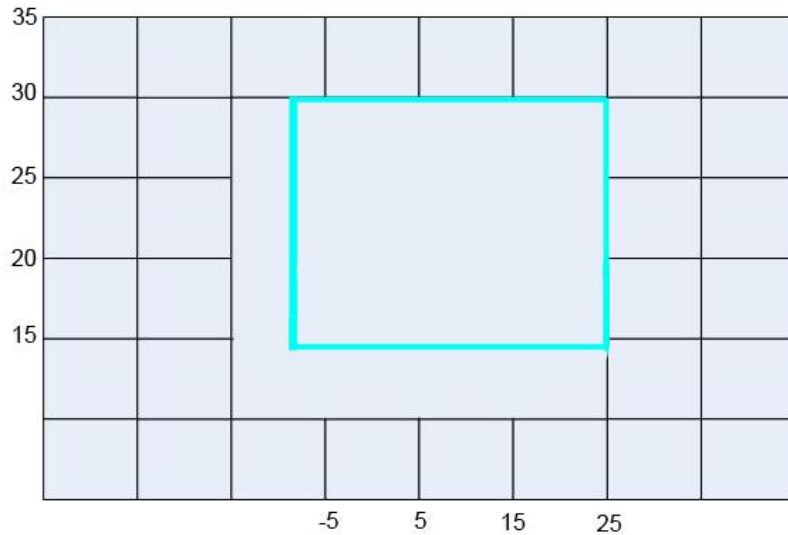

Outdoor unit air temp. °C DB

Note: The chart is the result from the continuous operation under constant air temperature conditions. However, excludes the initial pull-down stage.

7.

Schematic diagram and Wiring diagram

7.1 Schematic diagram

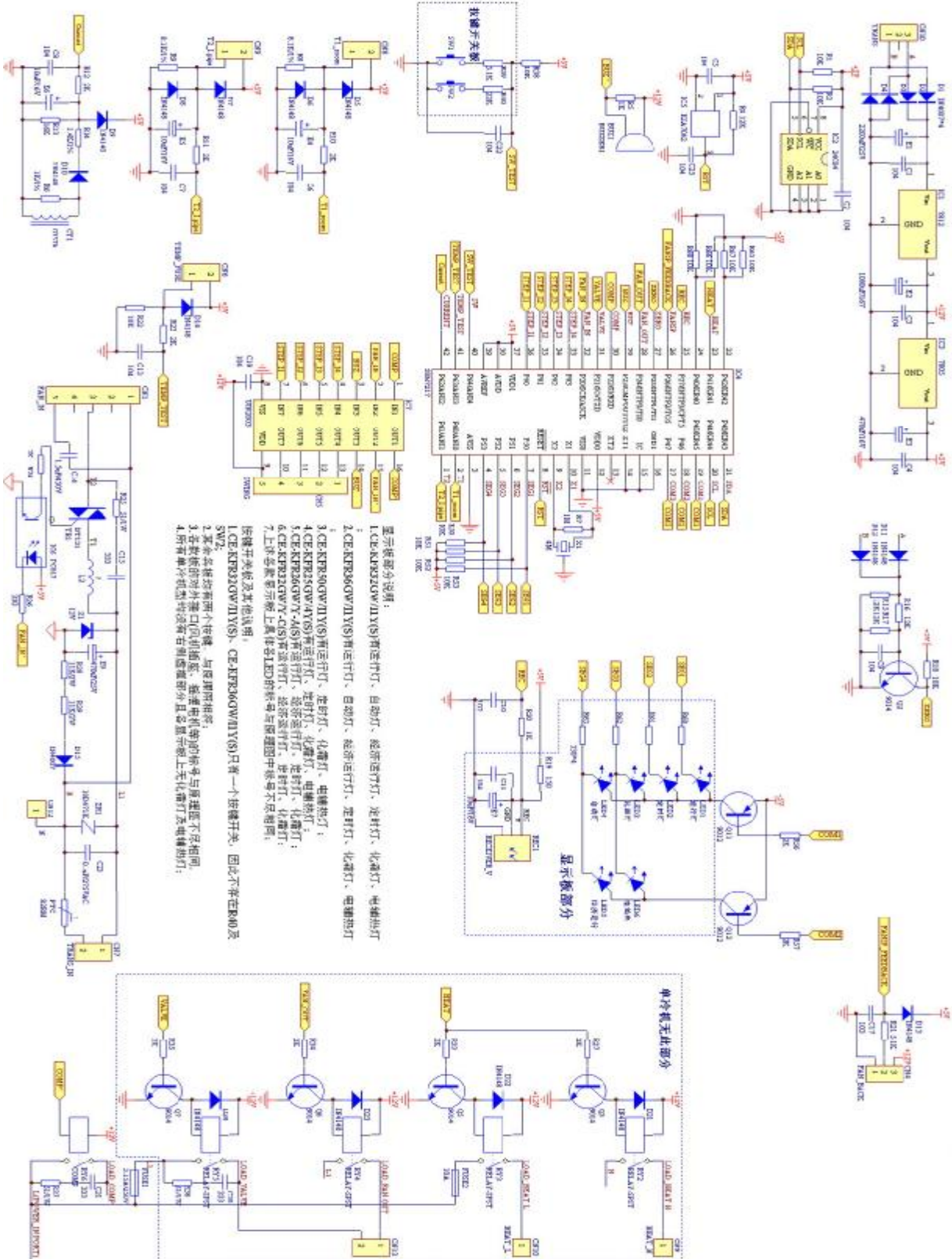

7.2 Wiring diagram

7.2.1 Heating mode

GC/GU-S24HR, GC/GU-S30HR

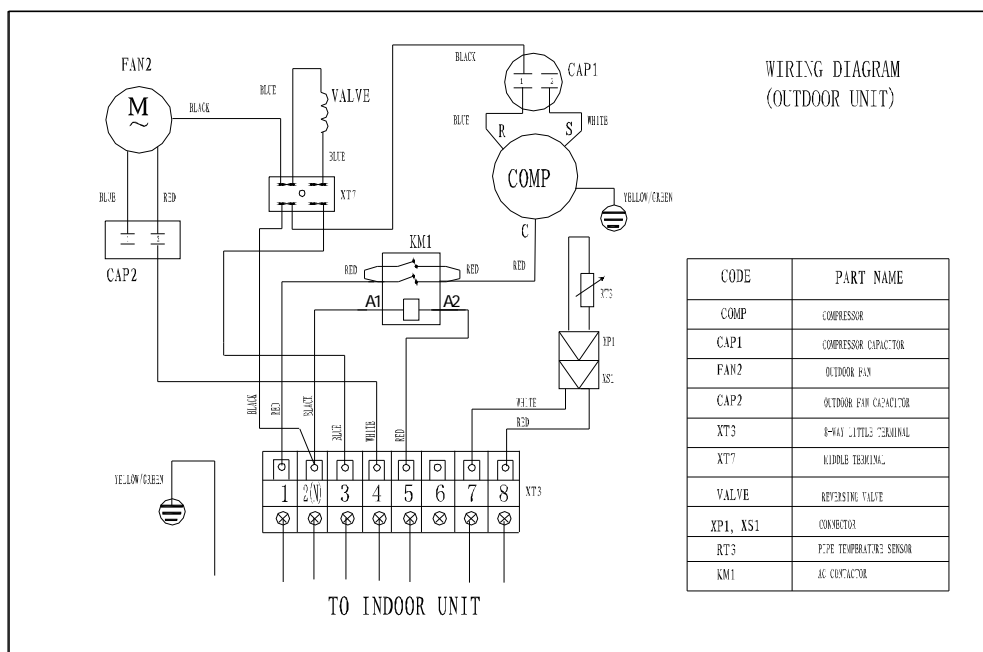
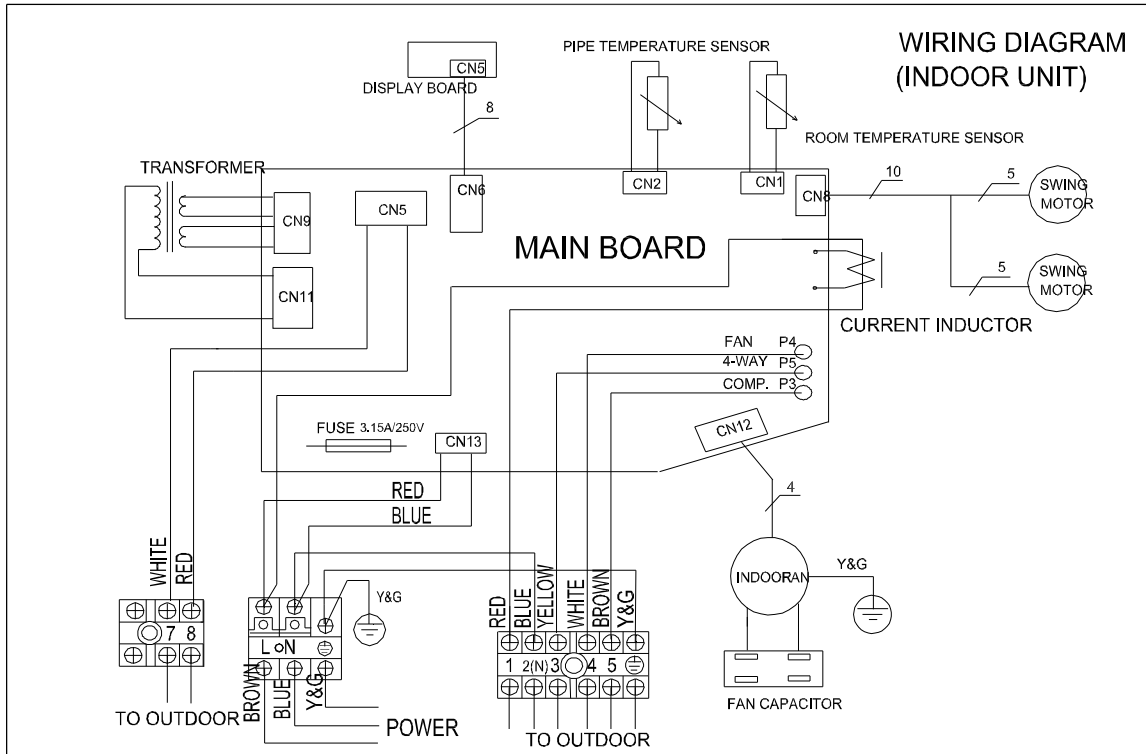

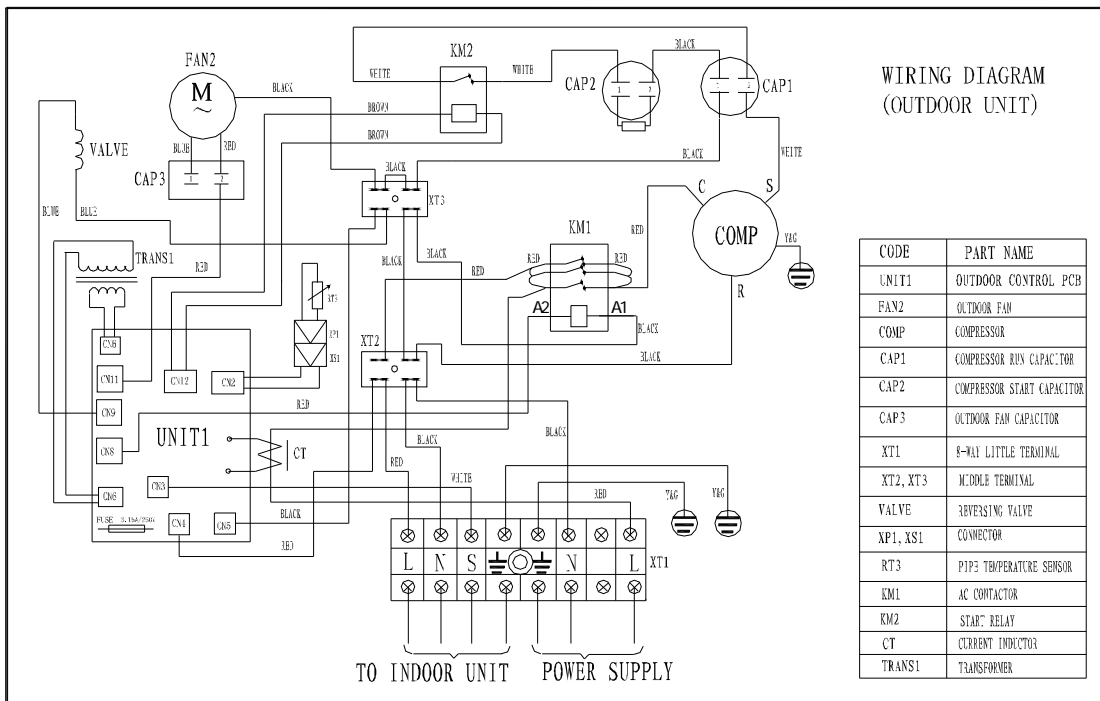
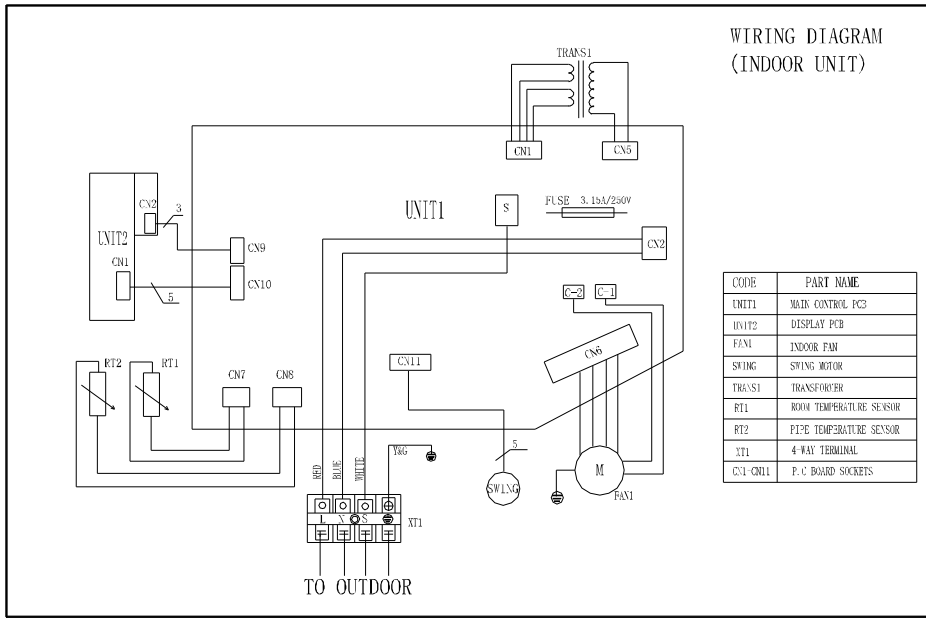

8. Installation details

8.1 Wrench torque sheet for installation

Outside diameter		Torque
mm	inch	Kg.m
φ6.35	1/4	1.8
φ9.52	3/8	4.2
φ12.7	1/2	5.5
φ15.88	5/8	6.6
φ19.05	3/4	6.6

8.2 Connecting the cables

The power cord of connect should be selected according to the following specifications sheet.

Unit	Grade		
	24K	30K	36K
mm ²	2,5	2,5	2,5

8.3 Pipe length and the elevation

Capacity	Pipe size		Standard length	Max.	Max.	Additional refrigerant
			(m)	Elevation	Elevation	
Btu/h	GAS	LIQUID		B (m)	A (m)	(g/m)
24K	5/8" (φ15.88)	3/8" (φ9.52)	5	10	20	65
30K~36K	5/8" (φ15.88)	3/8" (φ9.52)	5	15	30	65
	3/4" (φ19.05)	3/8" (φ9.52)	5	15	30	65

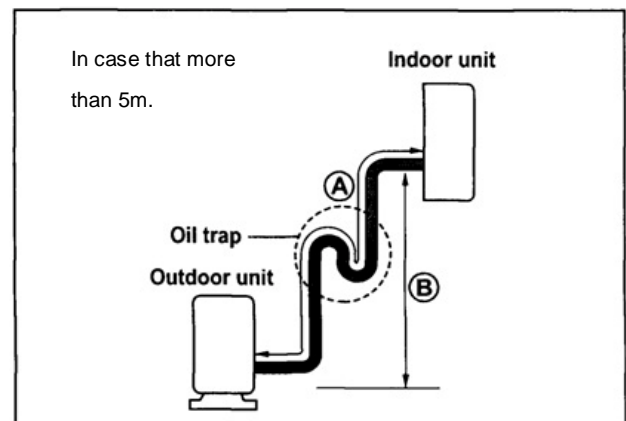
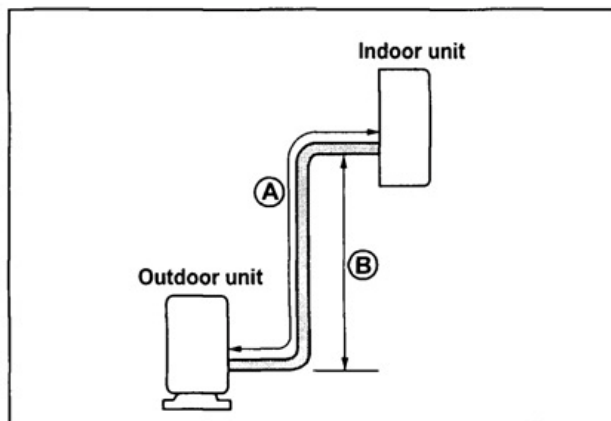

Caution:

Capacity is base on standard length and maximum allowance length is base of reliability.

Oil trap should be install per 5-7 meters.

8.4 Air purging of the piping and indoor unit

Required tools:

Hexagonal wrench; adjustable wrench; torque wrenches, wrench to hold the joints and gas leak detector.

Note:

The air in the indoor unit and in the piping must be purged. If air remains in the refrigeration piping, it will affect the compressor, reduce the cooling capacity, and could lead to a malfunction of unit.

Be sure, using a torque wrench to tighten the service port cap (after using the service port), so that it prevents the gas leakage from the refrigeration cycle.

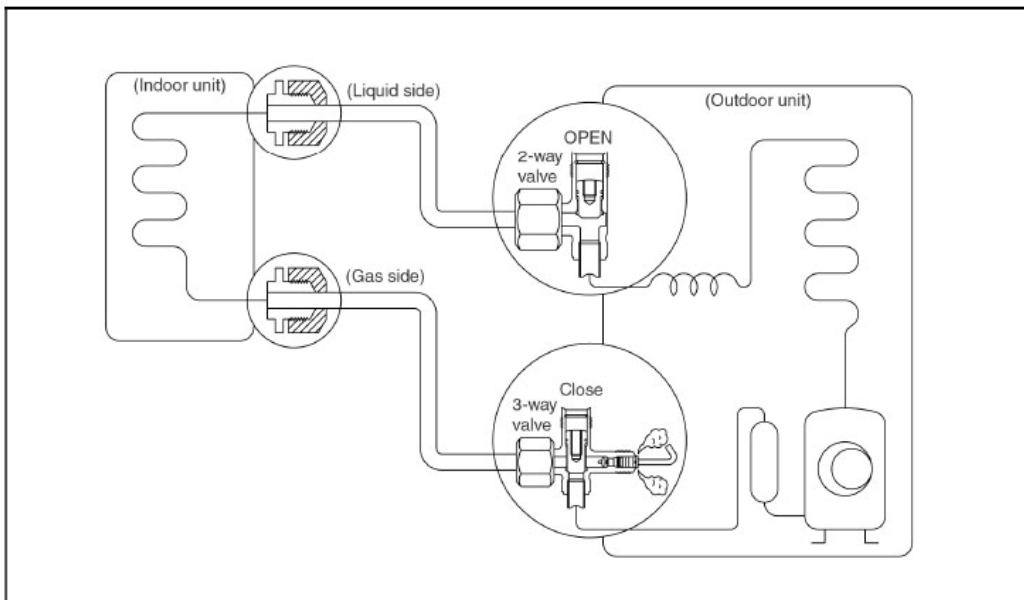

Procedure

1. Recheck the piping connections.
2. Open the valve stem of the 2-way valve counterclockwise approximately 90°, wait 10 seconds, and then set it to closed position.
 - § Be sure to use a hexagonal wrench to operate the valve stem
3. Check for gas leakage.
 - § Check the flare connection for gas leakage
4. Purge the air from the system.
 - § Set the 2-way valve to the open position and remove the cap from the 3-way valve's service port.
 - § Using the hexagonal wrench to press the valve core pin, discharge for three seconds and then wait for one minute.
5. Use torque wrench to tighten the service port cap to a torque of 1.8 kg.m. (18n.m)

6. Set the 3-way valve to the opened position.

7. Mounted the valve stem nuts to the 2-way and 3-way valves.

8. Check for gas leakage.

§ At this time, especially check for gas leakage from the 2-way and 3-way stem nuts, and from the service port.

Caution:

If gas leakage is discovered in step (3) above, take the following measures.

If the leaks stop when the piping connections are tightened further, continue working from step (4).

If the gas leaks do not stop when the connections are retightened, repair the location of the leak, discharge all of the gas through the service port, and then recharge with the specified amount of gas from a gas cylinder.

8.5 Pumping down (Re-installation)

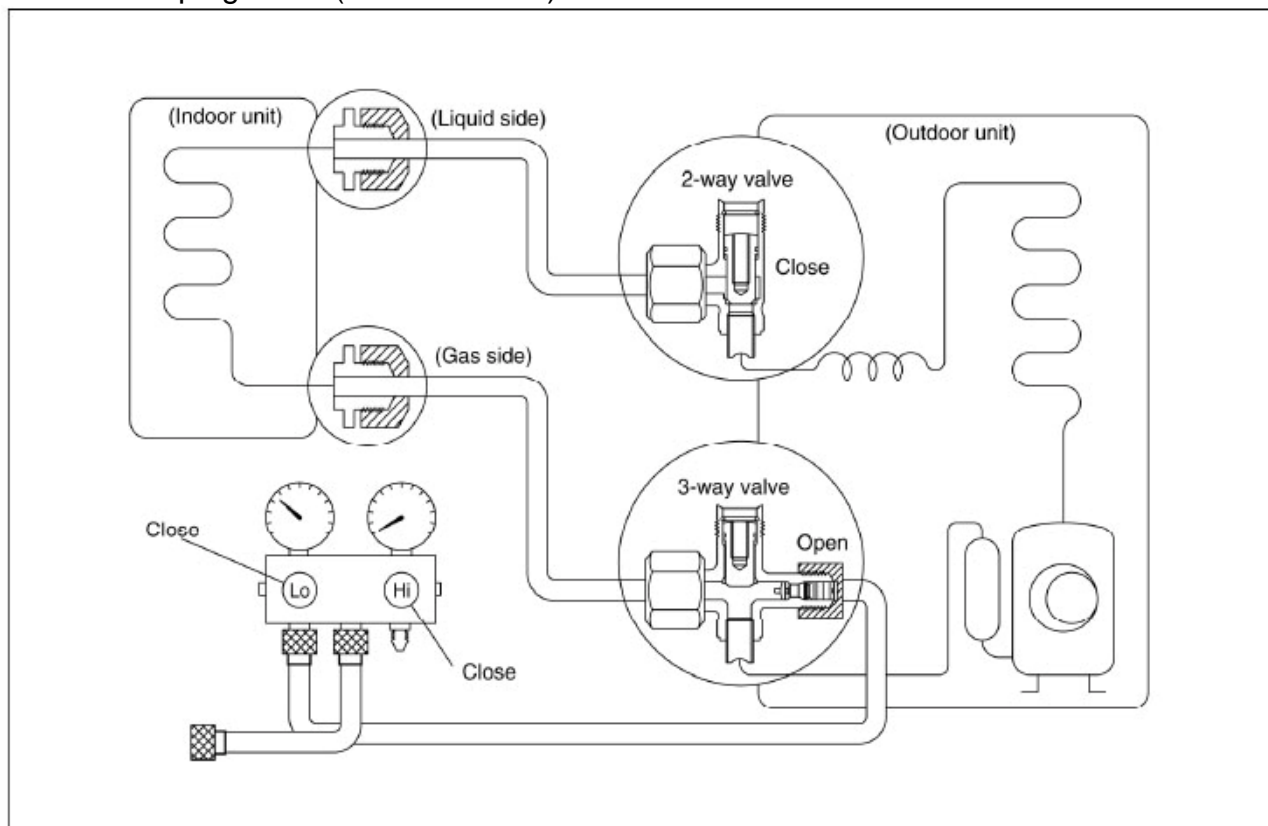

Procedure

1. Confirm that both the 2-way and 3-way valves are set to the opened position.

§ Remove the valve stem caps and confirm that the valve stems are in the opened position.

§ Be sure to use a hexagonal wrench to operate the valve stems.

2. Operate the unit for 10 to 15 minutes.

3. Stop operation and wait for 3 minutes, then connect the charge set to the service port of the 3-way valve.

§ Connect the charge hose with the push pin to the gas service port.

4. Air purging of the charge hose.

§ Open the low-pressure valve on the charge set slightly to purge air from the charge hose.

5. Set the 2-way valve to the close position.

6. Operate the air conditioner at the cooling cycle and stop it when the gauge indicates 0.1MPa.

7. Immediately set the 3-way valve to the closed position.

§ Do this quickly so that the gauge ends up indicating 0.3 to 0.5Mpa.

8. Disconnect the charge set, and amount the 2-way and 3-way valve's stem nuts and service port caps.

§ Use a torque wrench to tighten the service port cap to a torque of 1.8 kg.m.

§ Be sure to check for gas leakage.

8.6 Re-air purging (Re-installation)

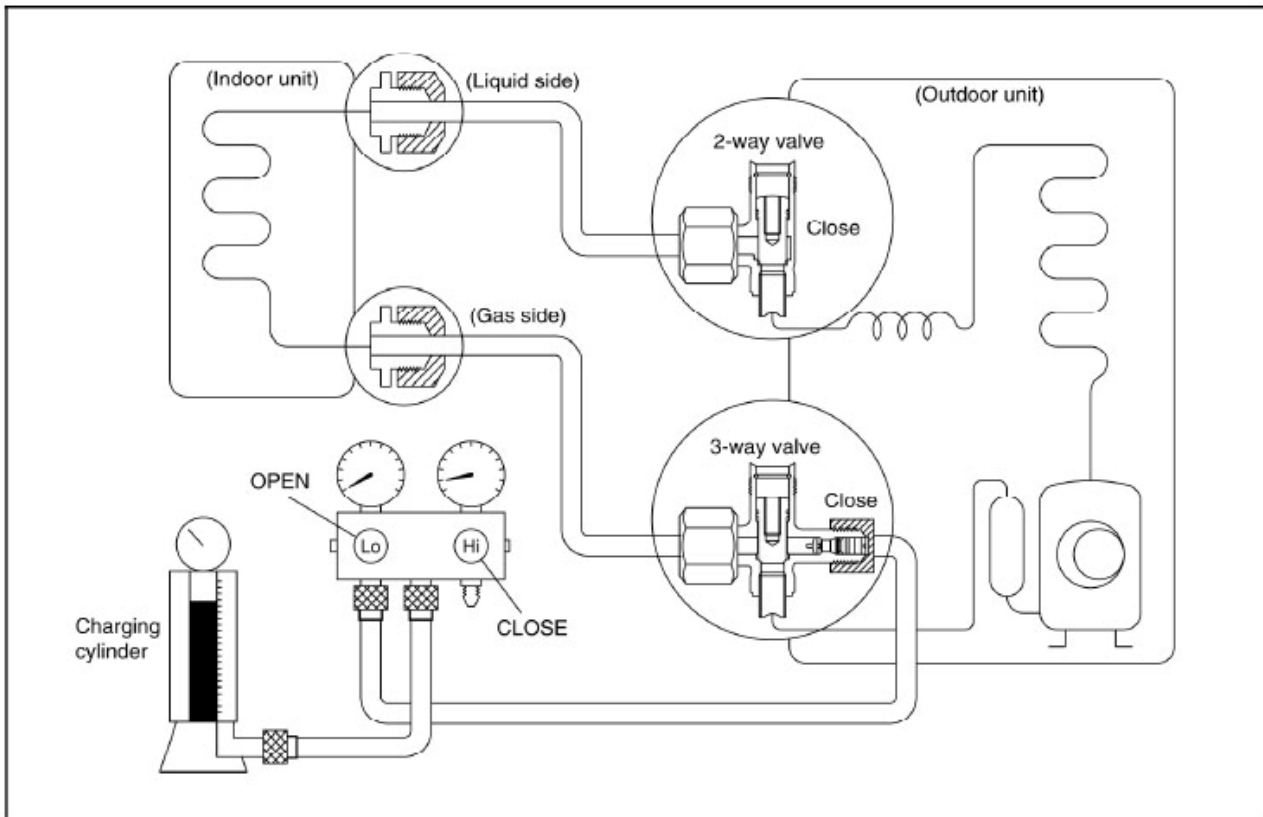

Procedure:

- 1. Confirm that both the 2-way and 3-way valves are set to the closed position.**
- 2. Connect the charge set and a charging cylinder to the service port of the 3-way valve.**
 - § Leave the valve on the charging cylinder closed.
- 3. Air purging.**
 - § Open the valves on the charging cylinder and the charge set. Purge the air by loosening the flare nut on the 2-way valve approximately 45° for 3 seconds then closing it for 1 minutes; repeat 3 times.
 - § After purging the air, use a torque wrench to tighten the flare nut to on the 2-way valve.
- 4. Check the gas leakage.**
 - § Check the flare connections for gas leakage.
- 5. Discharge the refrigerant.**
 - § Close the valve on the charging cylinder and discharge the refrigerant until the gauge indicate 0.3 to 0.5 Mpa.
- 6. Disconnect the charge set and the charging cylinder, and set the 2-way and 3-way valves to the open position.**
 - § Be sure to use a hexagonal wrench to operate the valve stems.
- 7. Mount the valve stems nuts and the service port cap.**
 - § Be sure to use a torque wrench to tighten the service port cap to a torque 18N.m.
 - § Be sure to check the gas leakage.

8.7 Balance refrigerant of the 2-way, 3-way valves

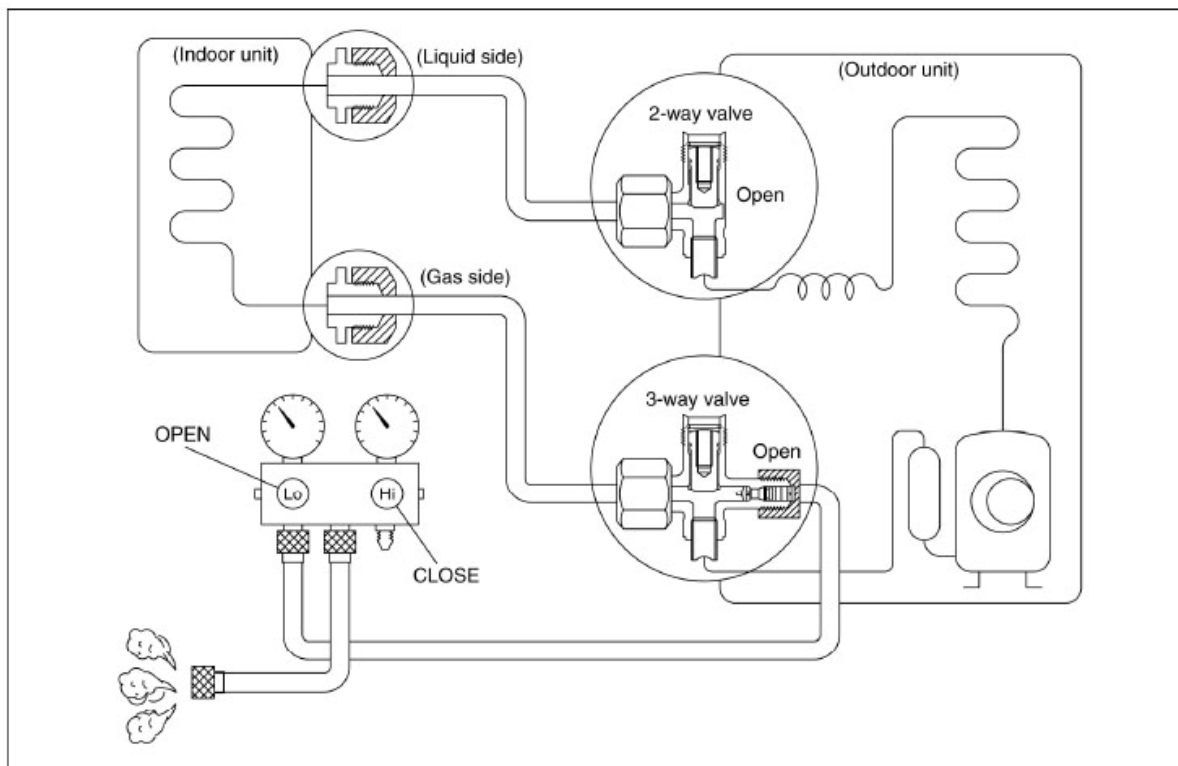

Procedure:

- 1. Confirm that both the 2-way and 3-way valves are set to the open position.**
- 2. Connect the charge set to the 3-way valve's service port.**
 - § Leave the valve on the charge set closed.
 - § Connect the charge hose with the push pin to the service port.
- 3. Open the valves (Low side) on the charge set and discharge the refrigerant until the gauge indicates 0.05 to 0.1 Mpa.**
 - § If there is no air in the refrigeration cycle [the pressure when the air conditioner is not running is higher than 0.1Mpa, discharge the refrigerant until the gauge indicates 0.05 to 0.1 Mpa. If this is the case, it will not be necessary to apply a evacuation.
 - § Discharge the refrigeration gradually; if it is discharged too suddenly, the refrigeration oil will be discharged.

8.8 Evacuation

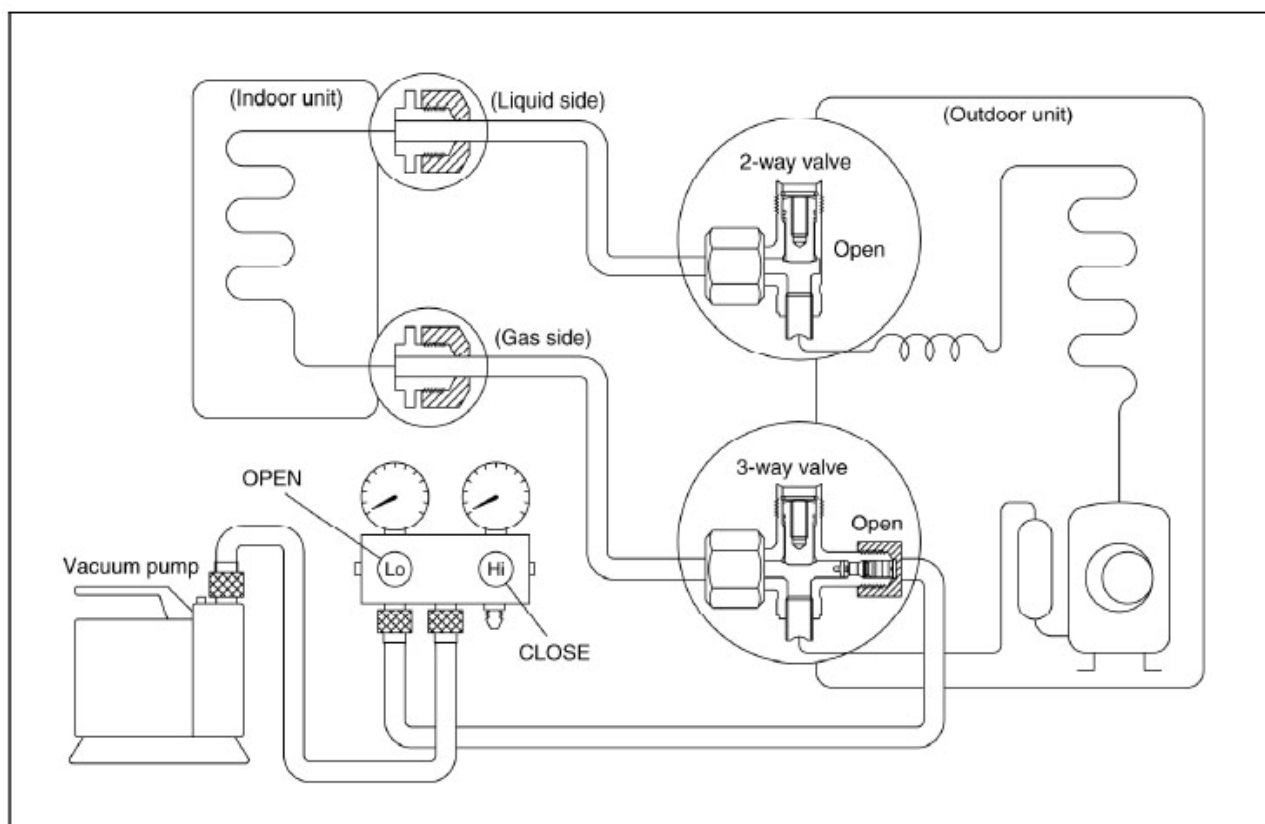

Procedure:

- 1. Connect the vacuum pump to the charge set's centre hose.**
- 2. Evacuation for approximately one hour.**
 - § Confirm that the gauge needle has moved toward -0.1 Mpa (-76 cmHg) [vacuum of 4 mmHg or less].
- 3. Close the valve (Low side) on the charge set, turn off the vacuum pump, and confirm that the gauge needle does not move (approximately 5 minutes after turning off the vacuum pump).**
- 4. Disconnect the charge hose from the vacuum pump.**
 - § Vacuum pump oil, if the vacuum pump oil becomes dirty or depleted, replenish as needle.

8.9 Gas charging

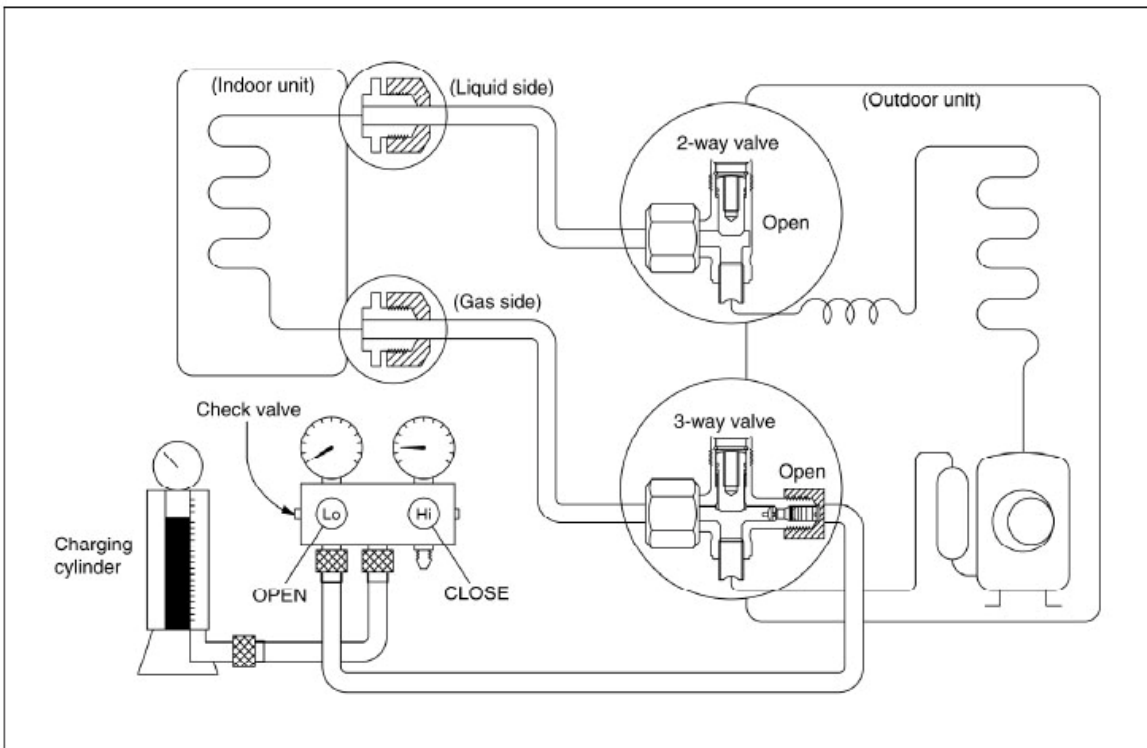

Procedure:

1. Connect the charge hose to the charging cylinder.

§ Connect the charge hose which you disconnected from the vacuum pump to the valve at the bottom of the cylinder.

2. Purge the air from the charge hose.

§ Open the valve at the bottom of the cylinder and press the check valve on the charge set to purge the air (be careful of the liquid refrigerant).

3. Open the valves (Low side) on the charge set and charge the system with liquid refrigerant.

§ If the system cannot be charge with the specified amount of refrigerant, it can be charged with a little at a time (approximately 150g each time) while operating the air conditioner in the cooling cycle; however, one time is not sufficient, wait approximately 1 minute and then repeat the procedure.(pumping down-pin).

4. Immediately disconnect the charge hose from the 3-way valve's service port.

§ Stopping partway will allow the refrigerant to be discharged.

§ If the system has been charged with liquid refrigerant while operating the air conditioner, turn off the air conditioner before disconnecting the hose.

5. Mounted the valve stem caps and the service port

§ Use torque wrench to tighten the service port cap to a torque of 18N.m.

§ Be sure to check for gas leakage.

9.

Capacity table

9.1 GC/GU-S24HR

SUMMER	<i>Cooling mode</i>	OUTDOOR TEMPERATURE DRY					
Indoor Conditions		25°C	30°C	35°C	40°C	45°C	50°C
21°C D 15°C W	Total capacity kW	6.76	6.35	5.88	5.41	5.05	4.69
	Sensitive capacity kW	4.93	4.74	4.44	4.11	3.86	3.61
	Input kW.	2.35	2.48	2.59	2.79	3.10	3.21
24°C D 17°C W	Total capacity kW	7.31	6.99	6.53	6.17	5.75	5.30
	Sensitive capacity kW	5.38	5.21	4.96	4.72	4.43	4.11
	Input kW.	2.43	2.56	2.67	2.88	3.20	3.31
27°C D 19°C W	Total capacity kW	7.79	7.44	7.03	6.64	6.19	5.71
	Sensitive capacity kW	5.92	5.73	5.48	5.22	4.88	4.51
	Input kW.	2.50	2.64	2.75	2.97	3.30	3.41
32°C D 23°C W	Total capacity kW	8.68	8.32	8.05	7.49	6.84	6.45
	Sensitive capacity kW	6.68	6.49	6.32	5.91	5.47	5.22
	Input kW.	2.60	2.75	2.86	3.09	3.43	3.55
WINTER		OUTDOOR CONDITIONS					
Indoor Conditions		12°C D 11°C W	7°C D 6°C W	4°C D 3°C W	0°C D -1°C W	-4°C D -6°C W	-7°C D -8°C W
15°C	Capacity kW	9.33	8.19	7.50	6.58	5.67	4.98
	Input kW.	2.95	2.68	2.50	2.31	2.01	1.83
18°C	Capacity kW	9.16	8.04	7.31	6.35	5.38	4.66
	Input kW.	3.03	2.73	2.53	2.37	2.07	1.85
20°C	Capacity kW	9.08	7.91	7.23	6.19	5.09	4.22
	Input kW.	3.11	2.75	2.61	2.42	2.13	1.95
22°C	Capacity kW	9.00	7.82	7.12	6.10	5.01	4.15
	Input kW.	3.22	2.78	2.65	2.51	2.27	2.03

9.2 GC/GU-S30HR

SUMMER		OUTDOOR TEMPERATURE DRY					
Indoor Conditions	Cooling mode	25°C	30°C	35°C	40°C	45°C	50°C
21°C D 15°C W	Total capacity kW	7.88	7.40	6.86	6.31	5.90	5.47
	Sensitive capacity kW	5.75	5.52	5.18	4.79	4.50	4.21
	Input kW.	2.74	2.89	3.01	3.25	3.61	3.73
24°C D 17°C W	Total capacity kW	8.53	8.15	7.62	7.20	6.71	6.19
	Sensitive capacity kW	6.27	6.07	5.79	5.51	5.17	4.79
	Input kW.	2.82	2.98	3.10	3.35	3.72	3.85
27°C D 19°C W	Total capacity kW	9.09	8.68	8.20	7.75	7.22	6.66
	Sensitive capacity kW	6.91	6.69	6.40	6.08	5.69	5.26
	Input kW.	2.91	3.07	3.20	3.46	3.84	3.97
32°C D 23°C W	Total capacity kW	10.12	9.71	9.39	8.73	7.98	7.52
	Sensitive capacity kW	7.79	7.57	7.37	6.90	6.38	6.09
	Input kW.	3.03	3.19	3.33	3.59	3.99	4.13
WINTER		OUTDOOR CONDITIONS					
Indoor Conditions		12°C D 11°C W	7°C D 6°C W	4°C D 3°C W	0°C D -1°C W	-4°C D -6°C W	-7°C D -8°C W
15°C	Capacity kW	10.37	9.10	8.33	7.31	6.30	5.53
	Input kW.	3.33	3.03	2.81	2.60	2.27	2.06
18°C	Capacity kW	10.18	8.93	8.13	7.06	5.98	5.18
	Input kW.	3.41	3.07	2.86	2.67	2.33	2.09
20°C	Capacity kW	10.09	8.79	8.03	6.88	5.66	4.69
	Input kW.	3.51	3.10	2.95	2.73	2.41	2.20
22°C	Capacity kW	10.00	8.69	7.91	6.78	5.56	4.61
	Input kW.	3.63	3.13	2.99	2.83	2.55	2.29

9.3 GC/GU-S36HR

SUMMER		<i>Cooling mode</i>		OUTDOOR TEMPERATURE DRY			
Indoor Conditions		25°C	30°C	35°C	40°C	45°C	50°C
21°C D 15°C W	Total capacity kW	9.87	9.27	8.59	7.90	7.38	6.85
	Sensitive capacity kW	7.21	6.92	6.48	6.00	5.64	5.28
	Input kW.	3.52	3.72	3.87	4.18	4.65	4.80
24°C D 17°C W	Total capacity kW	10.69	10.21	9.54	9.02	8.41	7.75
	Sensitive capacity kW	7.85	7.61	7.25	6.90	6.47	6.00
	Input kW.	3.64	3.84	4.00	4.32	4.80	4.96
27°C D 19°C W	Total capacity kW	11.38	10.88	10.27	9.71	9.05	8.34
	Sensitive capacity kW	8.65	8.37	8.01	7.62	7.13	6.59
	Input kW.	3.75	3.96	4.12	4.45	4.94	5.11
32°C D 23°C W	Total capacity kW	12.68	12.16	11.76	10.94	10.00	9.42
	Sensitive capacity kW	9.76	9.48	9.23	8.64	8.00	7.63
	Input kW.	3.90	4.11	4.28	4.63	5.14	5.31
WINTER		OUTDOOR CONDITIONS					
Indoor Conditions		12°C D 11°C W	7°C D 6°C W	4°C D 3°C W	0°C D -1°C W	-4°C D -6°C W	-7°C D -8°C W
15°C	Capacity kW	13.14	11.53	10.56	9.27	7.98	7.01
	Input kW.	4.42	4.02	3.74	3.46	3.02	2.73
18°C	Capacity kW	12.90	11.32	10.30	8.94	7.58	6.56
	Input kW.	4.53	4.08	3.80	3.55	3.10	2.78
20°C	Capacity kW	12.79	11.14	10.18	8.72	7.17	5.95
	Input kW.	4.66	4.12	3.91	3.63	3.20	2.93
22°C	Capacity kW	12.67	11.02	10.03	8.59	7.05	5.84
	Input kW.	4.83	4.16	3.97	3.77	3.40	3.04

10.

Electronic function

10.1 Electronic control working environment

Input voltage: 175~253V

Input power frequency: 50HZ

Ambient temperature: -7°C+43°C

Indoor fan normal working amp is less than 1A

Outdoor fan normal working amp is less than 1.5A

Four-way valve normal working amp is less than 1A

Swing motor: DC12V

Compressor: single-phase power supply. Its normal working amp is less than 15A

10.2 Proper symbols and their meaning

T1: Indoor ambient temperature

T2: Indoor evaporator temperature

T3: Outdoor condenser temperature.

TS: Setting temperature through the remote controller

I_{3sec}: Self-protection amp of compressor, continue three seconds until turns off the compressor.

I_{5MIN}: Self-protection amp of compressor, continue five minutes until turns off the compressor.

I_{FAN}: Self-protection amp of outdoor fan/indoor fans when they change from higher wind to lower wind.

I_{RESTORE}: Amp self-protection return value

TE1: Anti-cold wind, from Fan Off to Breeze temperature

TE2: Anti-cold wind, from Breeze to Setting Fan Speed temperature

TE3: Anti-cold wind, from Setting Fan Speed to Breeze temperature

TE4: Anti-cold wind, from Breeze to Fan Off temperature

TE5: Evaporator low temperature protection entering temperature

TE6: Evaporator low temperature protection restoring temperature

TE7: Evaporator high temperature protection, compressor off temperature

TE8: Evaporator high temperature protection, fan off temperature

TE9: Evaporator high temperature protection, restoring temperature

TE10: Condenser high temperature protection, compressor off temperature.

TE11: Condenser high temperature protection, restoring temperature.

TE14: The indoor restoring temperature when the compressor is off on the heating mode.

TE16: The indoor evaporator temperature after the defrost action, fan on temperature.

TC1: Outdoor condenser sensor temperature for the defrost condition 1.

TC2: Condenser sensor temperature after defrost.

TC3: Outdoor condenser sensor temperature for the defrost condition 2.

10.3Function

Remote receiving
Testing and forced running
Position set for indoor unit wind vane
LED displaying and alarm
On or off Timer
Protection for the compressor
Current protection
High temperature protection of indoor heat exchanger at heating mode
Auto defrosting and heating recovery at heating mode
Anti cold air at heating mode

10.4Protection

- 10.4.1 3 minutes delay at restart for compressor.
- 10.4.2 Sensor protection at open circuit and breaking disconnection
- 10.4.3 Fan Speed is out of control. When Indoor Fan Speed is too high(higher than High Fan+300RPM)or too low(lower than 400RPM), the unit stops and LED displays failure information and can't returns to normal operation automatically.
- 10.4.4 Cross Zero signal error warning. If there is no Cross Zero signals in 4 minutes, the unit stops and LED displays failure information and can't returns to normal operation automatically.
- 10.4.5 The current protection of the compressor

10.5Fan only mode

Fan speed is high/mid/low/ Auto

10.6Cooling mode

The 4-way valve is closed at cooling mode.

The action of the compressor and the outdoor fan:(T=indoor temperature)

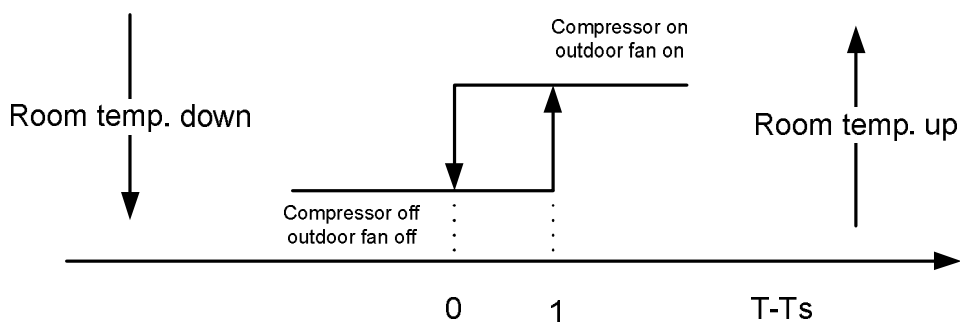

Auto fan at cooling mode:

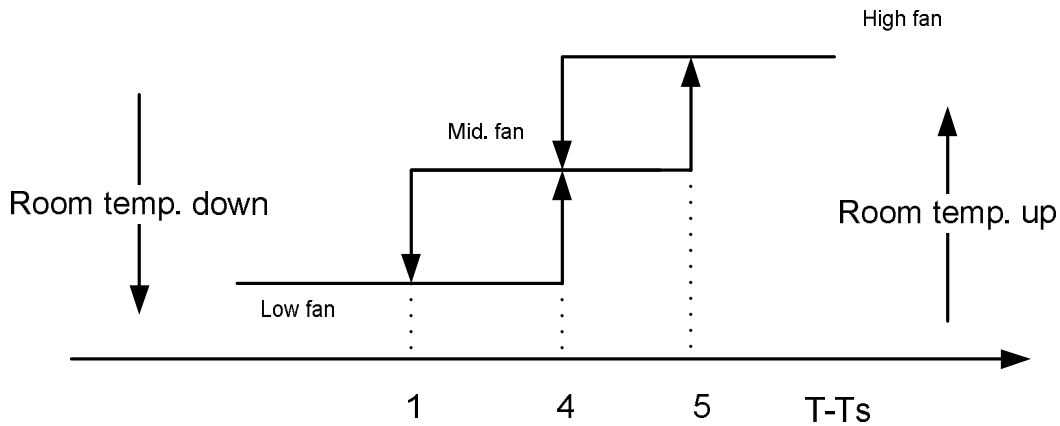

Anti-freezing control to indoor evaporator at cooling mode (T: evaporator temp.)

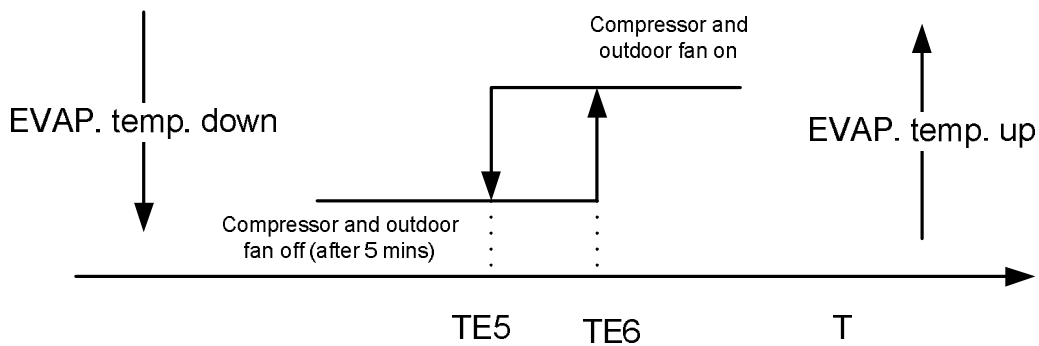

Condenser high temperature protection (only for heat pump)

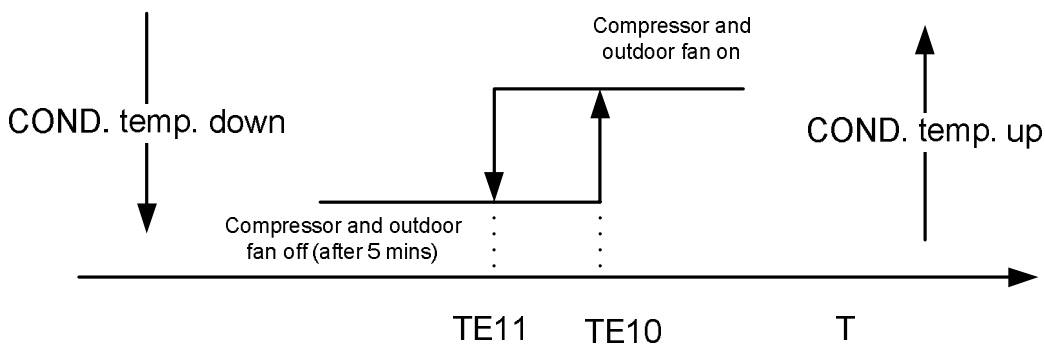

10.7 Dehumidifying mode

Indoor fan speed at low speed.

Protection is same as cooling mode.

10.8 Heating mode

10.8.1 Generally, the 4-way valve is open in heating mode, but it is closed in defrosting mode. 4-way valve must delay 2 minutes compared with compressor if the compressor changed into non-heating mode or turned off. 4-way valve doesn't delay in dehumidifying mode

10.8.2 Generally, the outdoor fan is turned off with the on-off action of compressor in heating mode, except for the defrosting mode or the end of defrost

10.8.3 Action of compressor and outdoor fan motor at heating mode: compressor must run for 7 minutes after starting and then judge temperature. Meanwhile other protections are still valid.

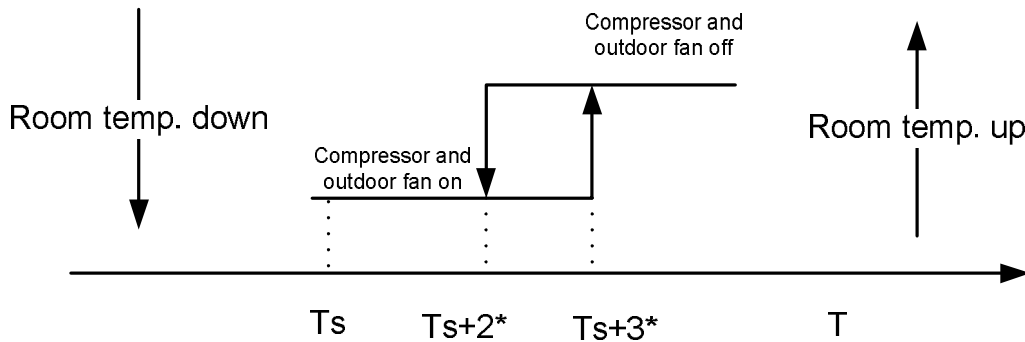

* This parameter can be changed from 0 to 3

10.8.4 Indoor Fan actions at heating mode

Indoor Fan can be set at HIGH/MID/LOW/AUTO by using a remote controller, but Anti-cold wind function prevails.

Anti-cold wind control function at heating mode (T=indoor exchanger temp.)

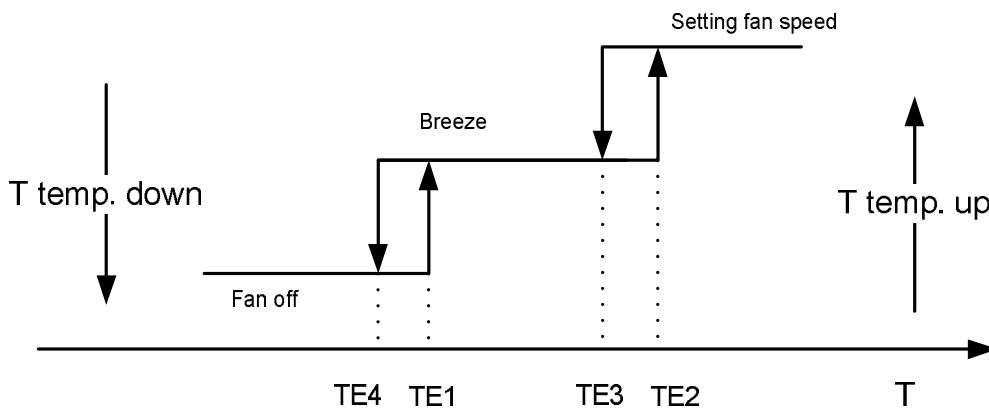

10.8.5 Auto wind at heating mode (T=indoor temp.)

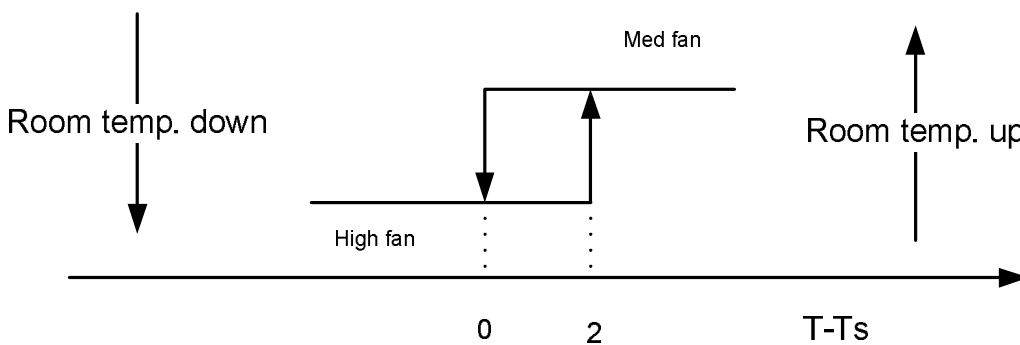

10.8.6 Indoor evaporator high-temperature protection at heating mode (T=indoor exchanger temp.)

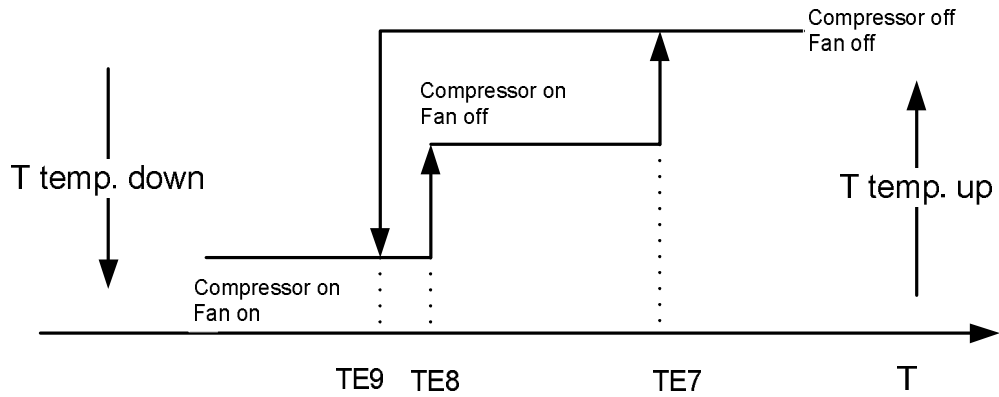

10.8.7 The louver opens to Standard Angle ANGLHEAT when power is on for the first time

10.8.8

10.8.9

10.9 Defrosting mode (available for heating mode)

10.9.1 Defrosting condition:

Defrost starts when either of the following:

T3 lower than 0°C, lasts for more than 40 minutes, provided that the time period then the temperature is lower than -3°C consecutively reaches 3 minutes.

Calculate from the end of latest defrost, evaporator high temp. protection only closes outdoor fan with the compressor still running. Add up to 90 minutes.

10.9.2 Conditions of defrost ending:

Defrosting ends when either of the following:

The time gets to 10 minutes.

T3 > 20°C.

The circulation is as following:

10.9.3 Defrosting Actions

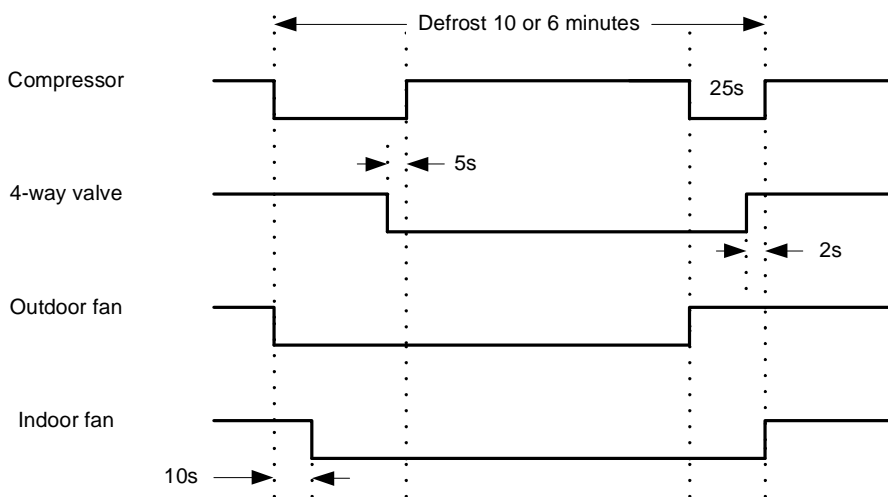

Remark: when the evaporator pipe temperature sensor more than TE16, the indoor fan start to run.

10.10 Auto mode

10.10.1 The air conditioner automatically selects one of the following operation modes: cooling, heating or fan only according to the temperature difference between room temperature (TA) and set temperature (TS).

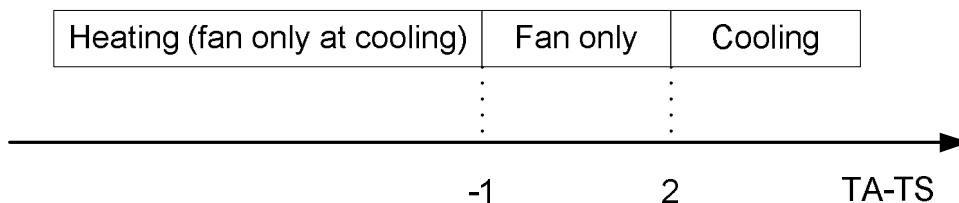

10.10.2 The indoor fan blows automatically in corresponding selected mode

10.10.3 The motion of indoor fan's blade should accord with the selected operation mode

10.10.4 One mode should be carried out for at least 15 minutes once selected. If the compressor cannot start for 15 minutes, reselect the operation mode according to the room temp. and set temp., or reselect when the set temp. varies

10.11 Force cooling function

10.11.1 Select forced cooling function with the forced cooling button or the switch

10.11.2 The compressor is unconditionally turned on, after 30 minutes cooling operation whose fan mode is set as low, the A/C operates at the DRY mode with a set temp. of 24°C

10.11.3 All protections of remote control cooling are available at forced cooling operation

10.11.4 Forced Auto function

Select forced auto function with the forced auto button or the switch.

In forced auto status the A/C operates at remote control mode with a set temp. of 24°C

Manual operation is controlled by touching buttons and divided into force cooling and forced auto mode. It transfer between these two modes by pressing the buttons, the cycling order of the button press is as below graph show to you.

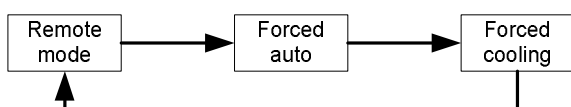

10.12 Sleep mode

10.12.1 The sleep function is available at cooling, heating or auto mode

10.12.2 Cooling:

The set temperature rise 1°C per hour. Two hours later, the set temperature will maintain as a constant and the fan speed is kept at low speed.

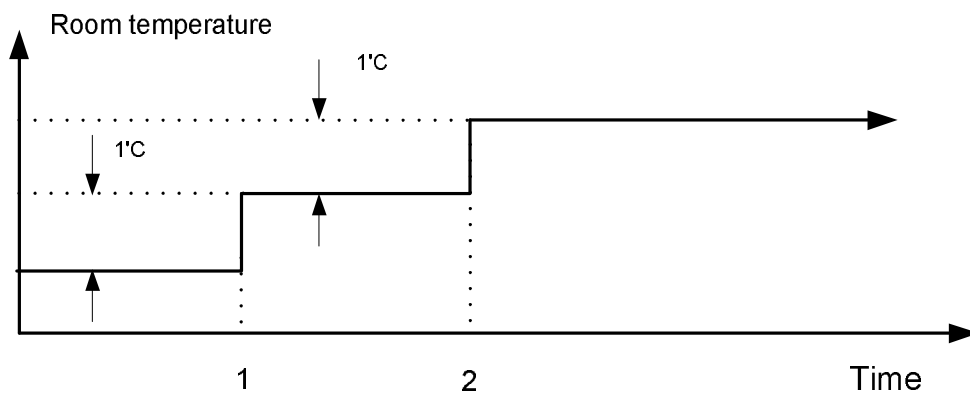

10.12.3 Heating:

The set temperature decrease 1°C per hour. Two hours later, the set temperature will maintain as a constant and the air circulation is kept at low speed (Anti-cold function takes precedence over all).

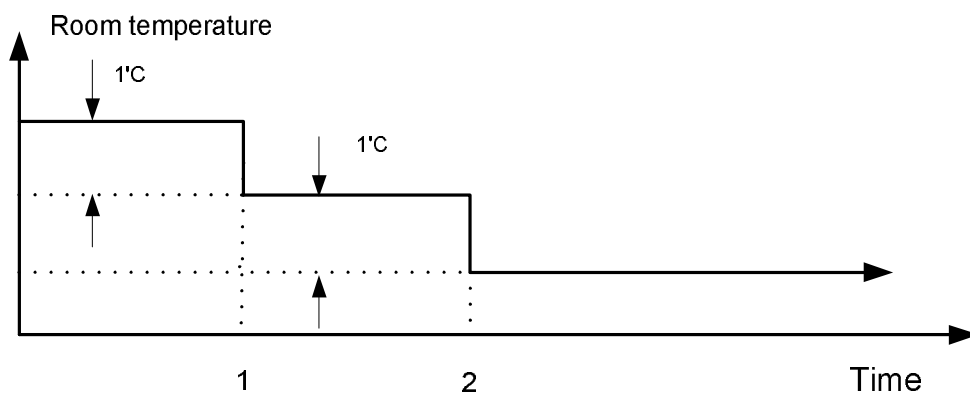

10.12.4 Auto:

After an hour running under economic mode, the set temp will rise 1°C, if it is under cooling mode; the set temp will decrease 1°C, if it is under heating mode; the set temp will be changeless, if it is under fan-only mode; the condition will be the same after the air conditioner running under economic mode after 2 hours, and during the next time the set temp do not change. The total time is 7 hours, after 7 hours the unit stops.

10.13 Auto restart function

In case of a sudden power failure, this function automatically sets the unit to previous settings before the power failure when power returns

11.

Model and Parameters

Model	GC/GU-S24HR	GC/GU-S30HR	GC/GU-S36HR
I3SEC [A]	22	26	34
I5MIN [A]	20	24	32
IFAN [A]	16	20	25
IDEFROST [A]	14	18	22
TE1 [°C]	25	25	30
TE2 [°C]	32	32	37
TE3 [°C]	30	30	34
TE4 [°C]	20	20	24
TE5 [°C]	2	2	2
TE6 [°C]	12	12	12
TE7 [°C]	63	63	63
TE8 [°C]	54	54	54
TE9 [°C]	50	50	50
TE10 [°C]	65	65	70
TE11 [°C]	55	55	65
TE14 [°C]	32	32	32
TE16 [°C]	42	42	34

12.

Troubleshooting

12.1 Display board

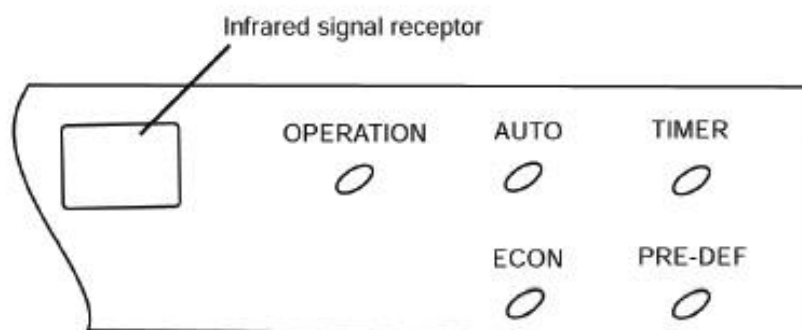

§ Operation

The indicator flashes once every second after power is on and illuminates when the air conditioner is in operation.

§ Timer indicator:

The indicator illuminates then TIMER is set ON.

§ PRE-DEF. indicator (For cooling & heating mode only)

The air conditioner starts defrosting automatically if outdoor unit frosts in heating operating.

At this time, PRE-DEF. indicator illuminates.

§ Auto indicator:

This indicator flashes when the air conditioner is in AUTO operation.

§ ECON indicator

This indicator illuminates while the air conditioner is in economic operation.

12.2 Troubleshooting

For cooling mode:

Failure phenomenon	Operation lamp	Timer lamp
Indoor fan speed has been out of control for over 1 minute	☆	X
Indoor room temp. or evaporator sensor is open circuit or short circuit	☆	On
Over current protection of the compressor occurs 4 times	X	☆
EEROM error	On	☆
No over-zero signal	☆	☆

⌞ Extinguish

☆ Flash at 5Hz

For heat pump mode:

Failure phenomenon	Operation lamp	Timer lamp	Defrosting lamp
Over current protection of the compressor occurs 4 times	☆	X	☆
Indoor fan speed has been out of control for over 1 minute	X	☆	☆
No over-zero signal	☆	☆	☆
Temp. sensor on indoor evaporator is open circuit or short circuit	X	X	☆
Indoor room temp. sensor is open circuit or short circuit	X	☆	X
EEROM error	On	☆	X

⌞ Extinguish

☆ Flash at 5Hz

12.3 Diagnostic chart

After energizing, no indicator is lighted and the air conditioner can't be operated.

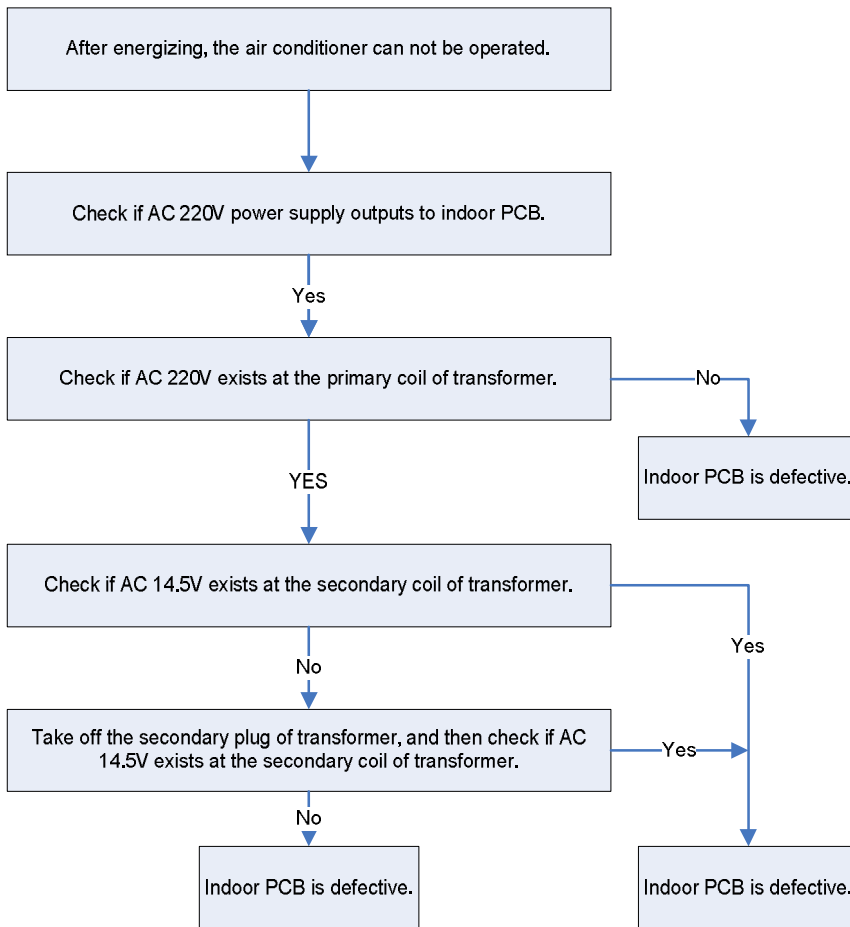

12.4 Resetting phenomenon often occurs during operation.

(That is automatically entering to the status when power is on.)

The reason is that the instantaneous voltage of main chip is less than 4.5V. Check according to the following procedure:

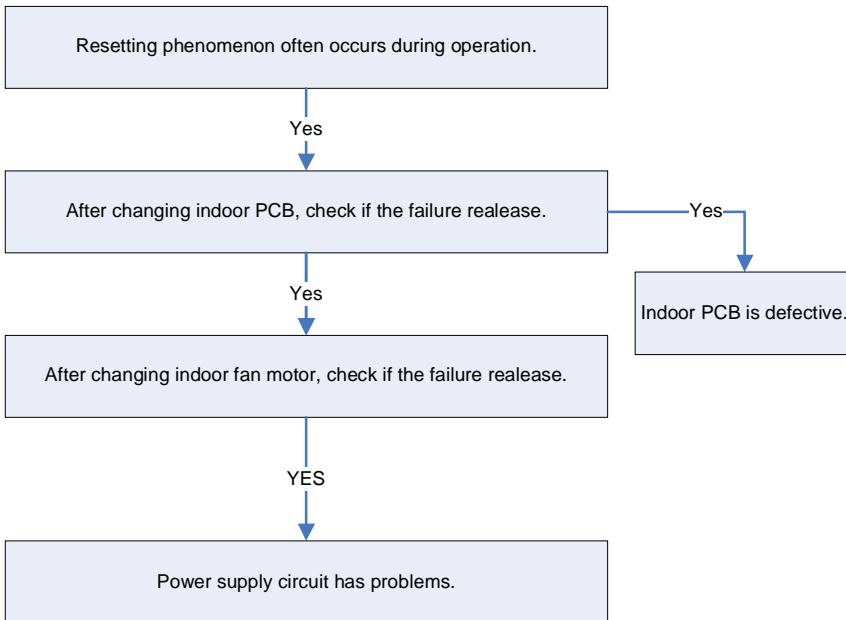

12.5 Operation lamp flashes and Timer lamp off.

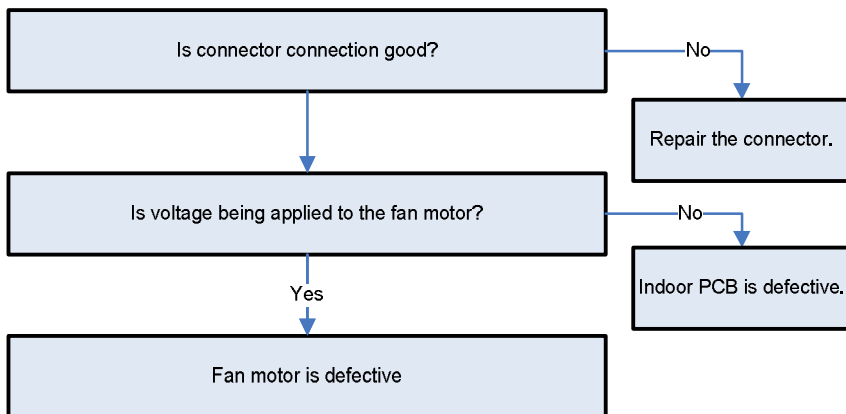

12.6 Operation lamp flashes and Timer lamp on.

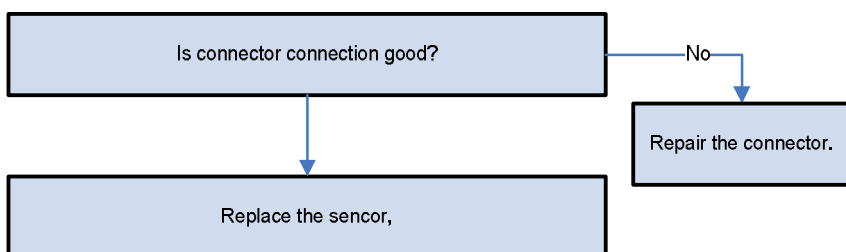

12.7 Operation lamp off and Timer lamp flashes

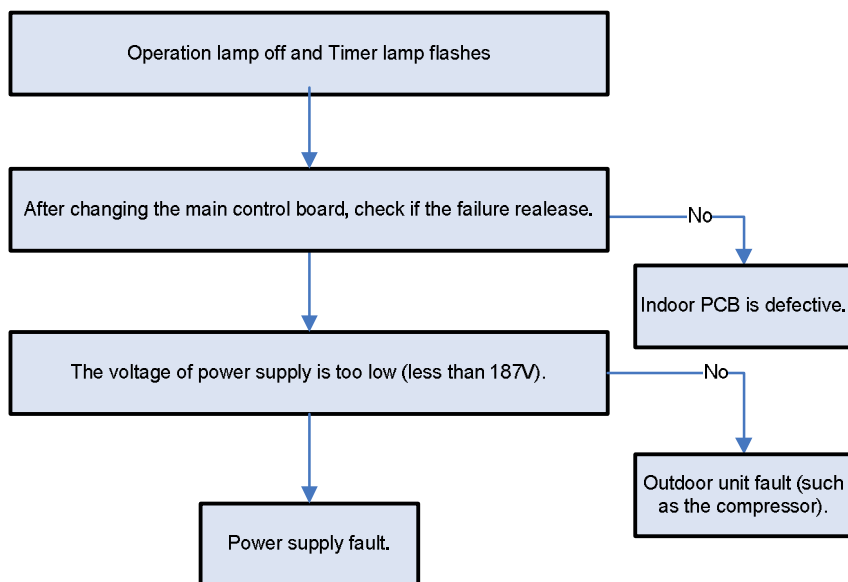

12.8 Operation lamp on and Timer lamp flashes

EEROM error, indoor PCB is defective.

12.9 Operation lamp flashes, Timer lamp flashes .

This is alarm signal when the main chip can't detect over-zero signal. When such failure occurs, the main control board must have fault.

13.

Characteristic of temperature sensor

Temp.°C	Resistance KΩ	Temp.°C	Resistance KΩ	Temp.°C	Resistance KΩ
-10	62.2756	17	14.6181	44	4.3874
-9	58.7079	18	13.918	45	4.2126
-8	56.3694	19	13.2631	46	4.0459
-7	52.2438	20	12.6431	47	3.8867
-6	49.3161	21	12.0561	48	3.7348
-5	46.5725	22	11.5	49	3.5896
-4	44	23	10.9731	50	3.451
-3	41.5878	24	10.4736	51	3.3185
-2	39.8239	25	10	52	3.1918
-1	37.1988	26	9.5507	53	3.0707
0	35.2024	27	9.1245	54	2.959
1	33.3269	28	8.7198	55	2.8442
2	31.5635	29	8.3357	56	2.7382
3	29.9058	30	7.9708	57	2.6368
4	28.3459	31	7.6241	58	2.5397
5	26.8778	32	7.2946	59	2.4468
6	25.4954	33	6.9814	60	2.3577
7	24.1932	34	6.6835	61	2.2725
8	22.5662	35	6.4002	62	2.1907
9	21.8094	36	6.1306	63	2.1124
10	20.7184	37	5.8736	64	2.0373
11	19.6891	38	5.6296	65	1.9653
12	18.7177	39	5.3969	66	1.8963
13	17.8005	40	5.1752	67	1.83
14	16.9341	41	4.9639	68	1.7665
15	16.1156	42	4.7625	69	1.7055
16	15.3418	43	4.5705	70	1.6469

Exploded View Parts for Model GC-S24HR 220-240V, 50Hz : Indoor Unit

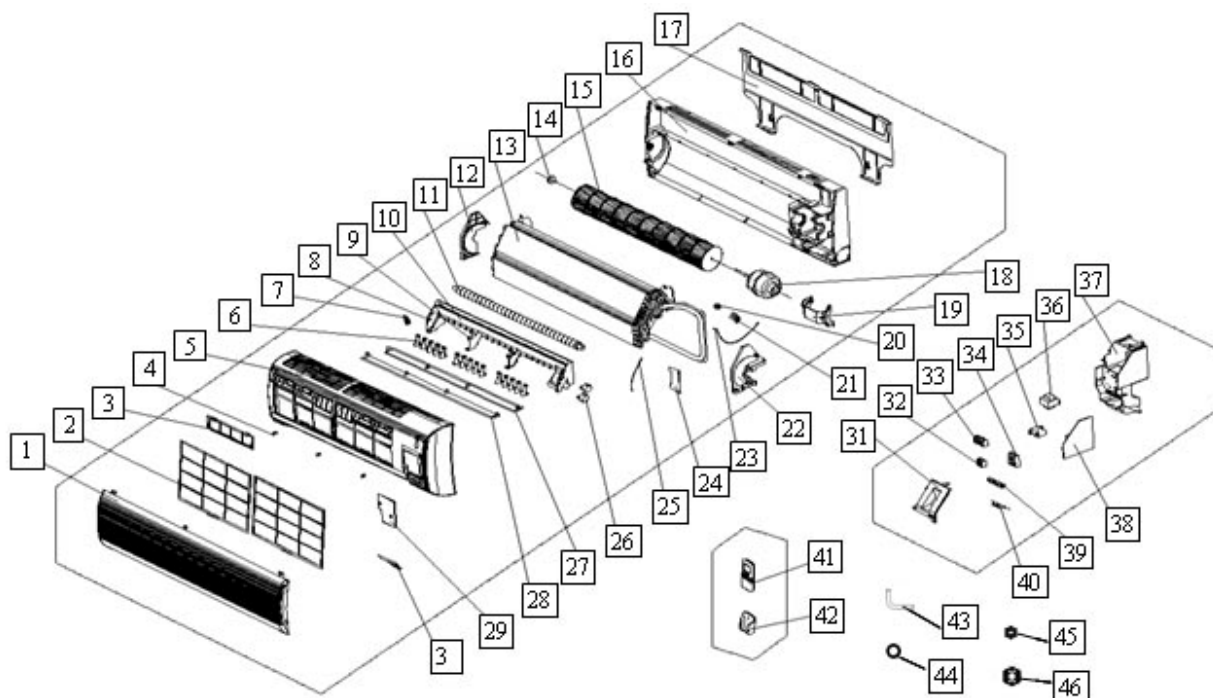

No.	Part Name	Quantity	Sale code
1	Front panel	1	10321121003
2	Air filter	2	10321111001
3	Air cleaner	1	10321111002
4	Screw cap	3	10321111003
5	Panel frame	1	10321121004
6	Horizontal airflow grille	15	10321121005
	Grille holder	3	10321121006
7		1	10321121007
8	Big bush	2	10321121008
9	Small bush	4	10321121009
10	Air out frame	1	10321121010
11	Drain hose	1	10118121223
12	Left holder for evaporator	1	10321111004
13	Evaporator	1	10924121003
14	Bearing holder	1	10321111008
15	Cross flow fan, assy	1	10321111009

16	Chassis	1	10321111010
17	Installation Plate	1	10321111011
18	Fan motor	1	10321111012
19	Fixing part for motor	1	10321111013
20	Protector for temp sensor	1	10112121224
21	Clamp for temp sensor	1	10109121231
22	Right holder for evaporator	1	10321111014
23	Indoor temp sensor	1	10118121242
24	Connecting pipe clamp	1	10321111015
25	Evaporator temp sensor	1	10109121242
26	Louver motor	1	10321111016
27	Vertical airflow louver , down	1	10321121011
28	Vertical airflow louver , up	1	10321121012
29	Window cover for repairing	1	10321111017
30	Control assy	1	10321121013
31	E-part box cover	1	10321111018
32	Terminal block	1	10321121001
33	Terminal block	1	10121121227
34	Terminal block	1	10121121233
35	Fan motor capacitor	1	50309121808
36	Transformer	1	10118121232
37	E-Parts box	1	10321111019
38	Main control board	1	10321121002
39	Wire clamp for power cord	1	10121121234
40	Display board	1	10321111021
	Display board enclosure	1	10321111022
41	Remote controller	1	10109121207
42	Holder for remote controller	1	10109121208
43	Connection pipe for drainage	1	11609121003
44	Sealing ring	1	31009321021
45	Copper nut, TLM-B02	1	10909121013
46	Copper nut, TLM-D04	1	11324113804

Exploded View Parts for Model GU-S24HR 220--240V,50Hz : Outdoor Unit

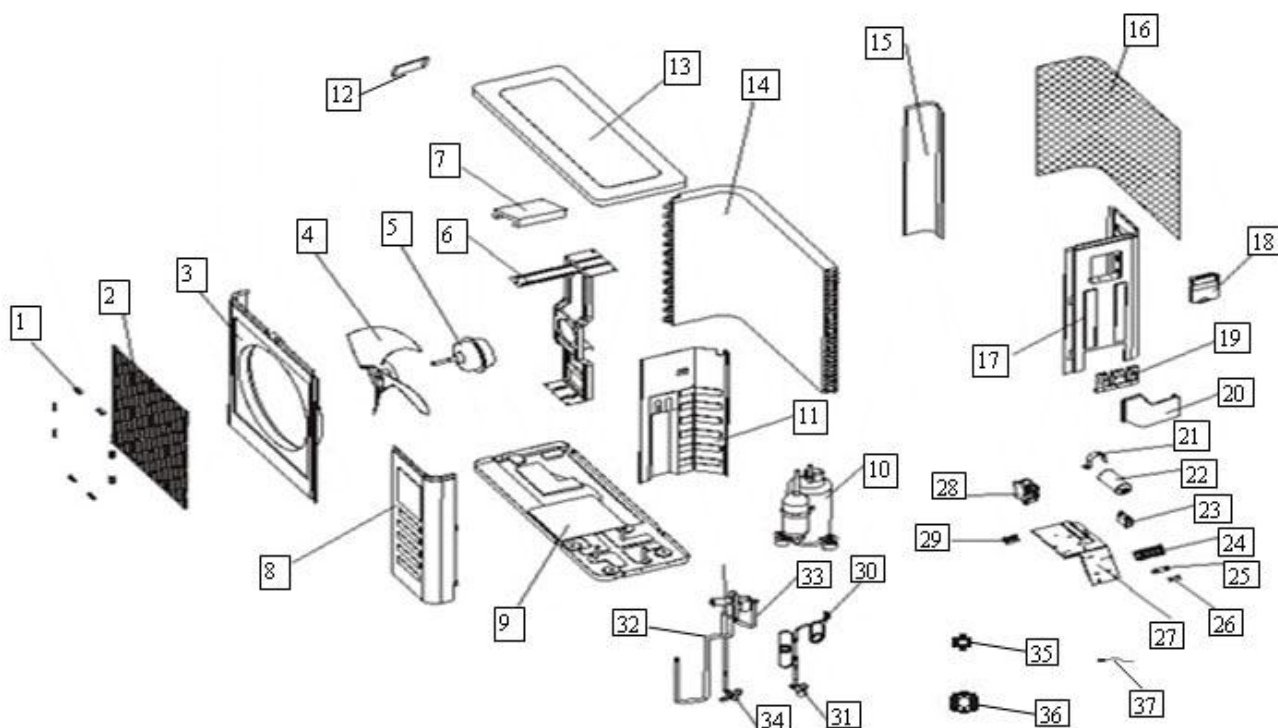

No.	Part Name	Quantity	Sale code
1	Front net	1	10118121801
2	Clamp for front net	8	10112121801
3	Front clapboard	1	10924121801
4	Propeller fan	1	10118121804
5	Fan Motor	1	10121121801
6	Holder for fan motor	1	10118121809
7	Foam over holder for motor	1	10118121807
8	Front right clapboard	1	10118121819
9	Chassis	1	10122113803
10	Compressor	1	10124111813
11	Separating board	1	10121121803
12	Little Handle	1	10830121811
13	Cover	1	10118121827
14	Condenser	1	11318123802
15	Left clapboard	1	10924121808
16	Rear Net	1	10924121809

17	Rear right clapboard	1	10118113804
18	Big Handle	1	10118121817
19	Installation plate for valves	1	10118113805
20	Water collector	1	10118121832
21	Capacitor Clamp	1	10112121814
22	Compressor capacitor	1	10118121820
23	Fan motor capacitor	1	10109121819
24	Wire joint	1	10124121810
25	Washer for wire joint	1	10112121817
26	Clamp for wiring	1	10118121823
27	Installation board for E-parts	1	10424121802
28	Contactora	1	10121121806
29	Wire joint for multiplexer	1	10121121809
30	High Pressure Valve Ass'y	1	10124121815
31	Liquid pipe valve	1	10124121812
32	Low Pressure Valve Ass'y	1	10124121805
33	4-way valve	1	10312121852
34	Low Pressure Valve	1	10124121814
35	Copper nut, TLM-B02	1	10909121013
36	Copper nut, TLM-D04	1	11324113804
37	Condenser temp sensor	1	10118121828

Exploded View Parts for Model GC-S30HR 220-240V, 50Hz : Indoor Unit

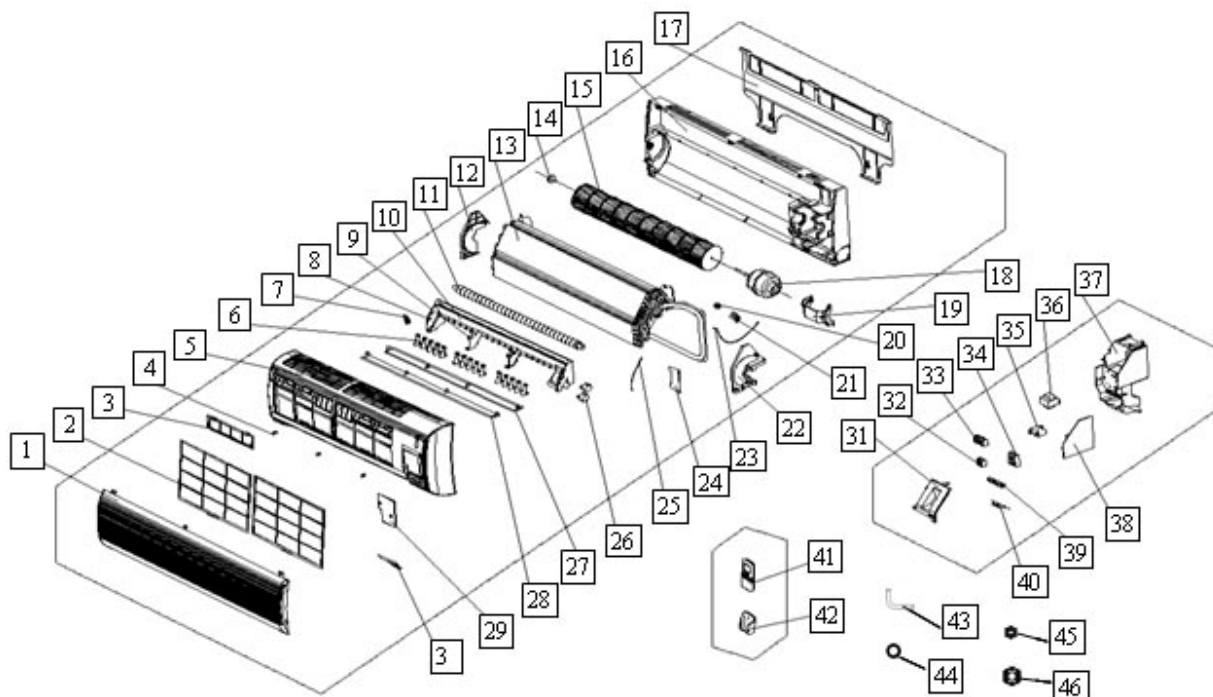

No.	Part Name	Quantity	Sale code
1	Front panel	1	10321121003
2	Air filter	2	10321111001
3	Air cleaner	1	10321111002
4	Screw cap	3	10321111003
5	Panel frame	1	10321121004
6	Horizontal airflow grille	15	10321121005
	Grille holder	3	10321121006
7	Stopple	1	10321121007
8	Big bush	2	10321121008
9	Small bush	4	10321121009
10	Air out frame	1	10321121010
11	Drain hose	1	10118121223
12	Left holder for evaporator	1	10321111004
13	Evaporator	1	10924121003
14	Bearing holder	1	10321111008
15	Cross flow fan, assy	1	10321111009
16	Chassis	1	10321111010

17	Installation Plate	1	10321111011
18	Fan motor	1	10321111012
19	Fixing part for motor	1	10321111013
20	Protector for temp sensor	1	10112121224
21	Clamp for temp sensor	1	10109121231
22	Right holder for evaporator	1	10321111014
23	Indoor temp sensor	1	10118121242
24	Connecting pipe clamp	1	10321111015
25	Evaporator temp sensor	1	10109121242
26	Louver motor	1	10321111016
27	Vertical airflow louver , down	1	10321121011
28	Vertical airflow louver , up	1	10321121012
29	Window cover for repairing	1	10321111017
30	Control assy	1	10321121013
31	E-part box cover	1	10321111018
32	Terminal block	1	10321121001
33	Terminal block	1	10121121227
34	Terminal block	1	10121121233
35	Fan motor capacitor	1	10109121819
36	Transformer	1	10118121232
37	E-Parts box	1	10321111019
38	Main control board	1	10324121001
39	Wire clamp for power cord	1	10121121234
40	Display board	1	10321111021
	Display board enclosure	1	10321111022
41	Remote controller	1	10109121207
42	Holder for remote controller	1	10109121208
43	Connection pipe for drainage	1	11609121003
44	Sealing ring	1	31009321021
45	Copper nut, TLM-B02	1	10909121013
46	Copper nut, TLM-D04	1	11324113804

Exploded View Parts for Model GU-S30HR 220-240V, 50Hz : Outdoor Unit

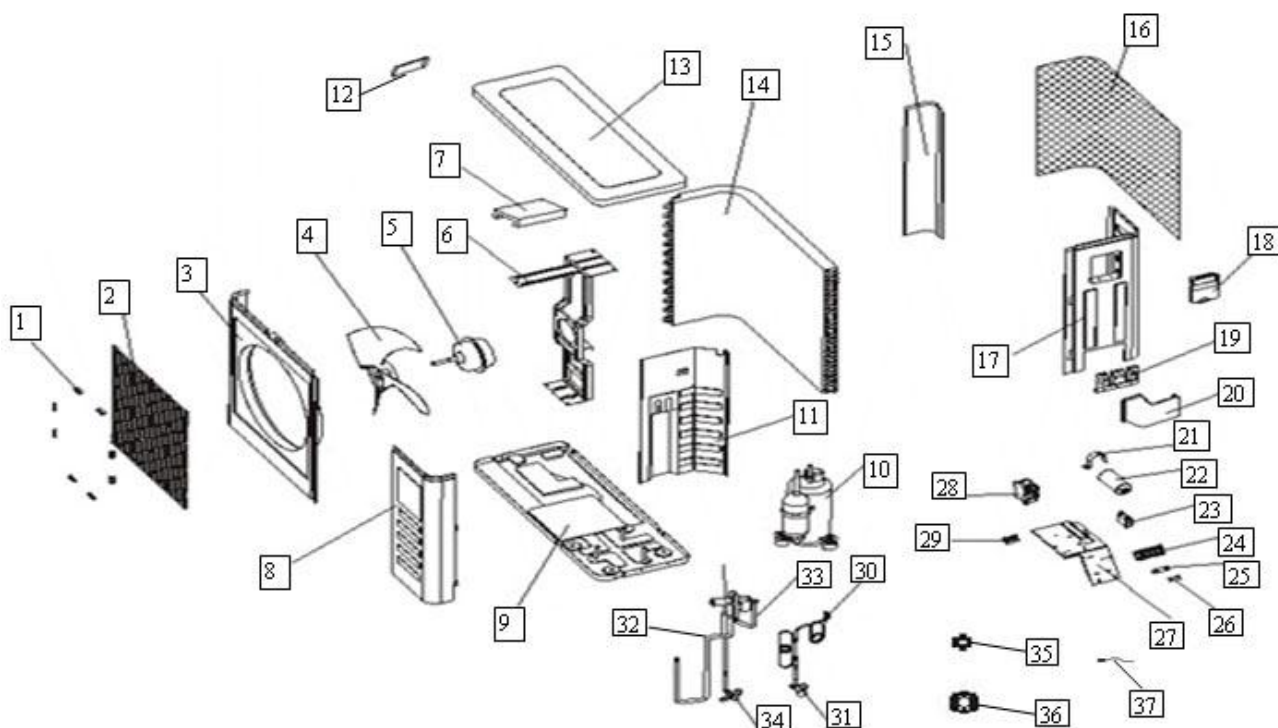

No.	Part Name	Quantity	Sale code
1	Front net	1	10118121801
2	Clamp for front net	8	10112121801
3	Front clapboard	1	10924121801
4	Propeller fan	1	10118121804
5	Fan Motor	1	10121121801
6	Holder for fan motor	1	10118121809
7	Foam over holder for motor	1	10118121807
8	Front right clapboard	1	10118121803
9	Chassis	1	10124121801
10	Compressor	1	10124121809
11	Separating board	1	10124121803
12	Little Handle	1	10830121811
13	Cover	1	10118121827
14	Condenser	1	11318123802
15	Left clapboard	1	10924121808
16	Rear Net	1	10924121809
17	Rear right clapboard	1	10118113804

18	Big Handle	1	10118121817
19	Installation plate for valves	1	10118113805
20	Water collector	1	10118121832
21	Capacitor Clamp	1	10112121814
22	Compressor capacitor	1	10118121820
23	Fan motor capacitor	1	10124121806
24	Wire joint	1	10124121810
25	Washer for wire joint	1	10112121817
26	Clamp for wiring	1	10118121823
27	Installation board for E-parts	1	10424121802
28	Contactator	1	10121121806
29	Wire joint for multiplexer	1	10121121809
30	High Pressure Valve Ass'y	1	15024121802
31	Liquid pipe valve	1	10124121812
32	Low Pressure Valve Ass'y	1	15024121803
33	4-way valve	1	10312121852
34	Low Pressure Valve	1	10124121814
35	Copper nut, TLM-B02	1	10909121013
36	Copper nut, TLM-D04	1	11324113804
37	Condenser temp sensor	1	10121121816

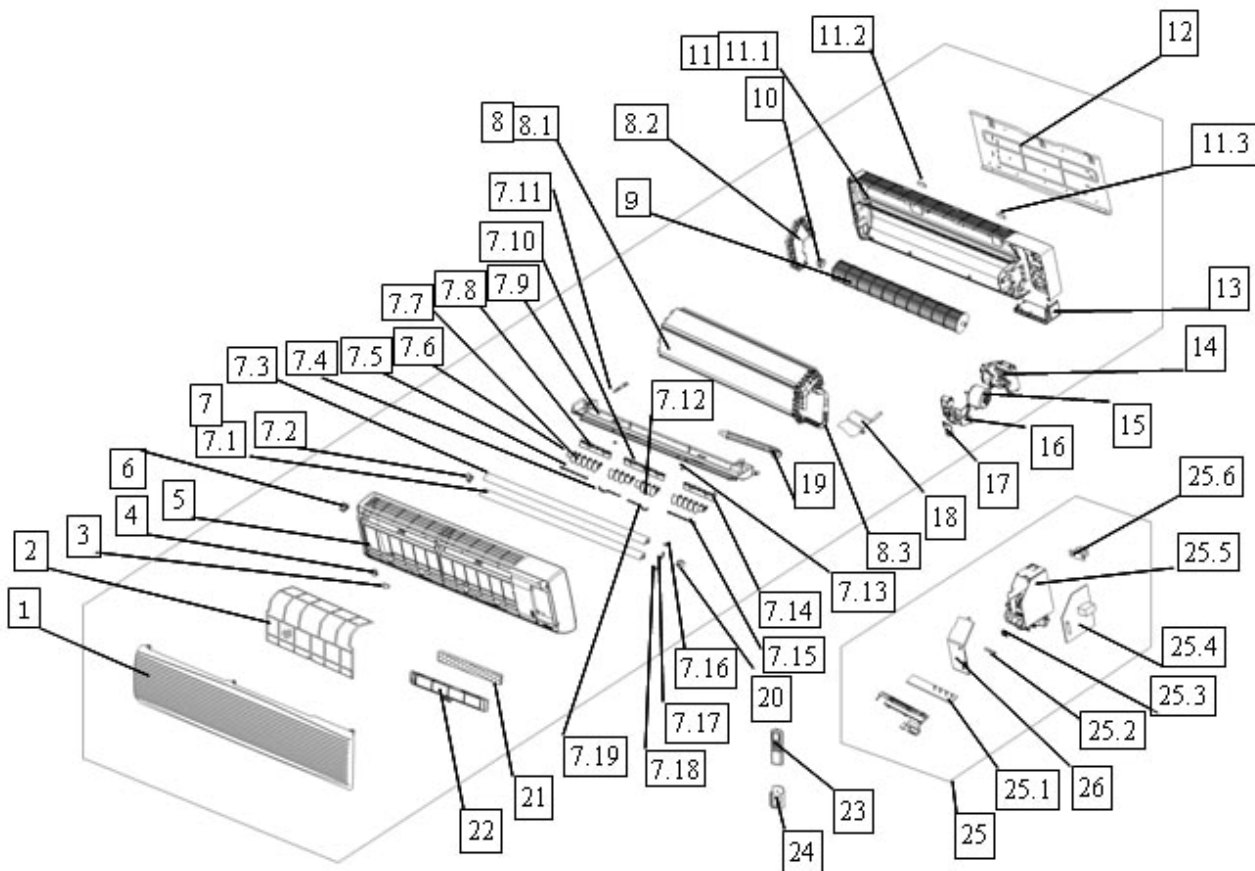

No	Name	Quantity	Sale code
1	Front panel	1	10336111001
2	Air filter	2	10336111002
3	Screw cap	3	10336111003
4	Down clap for panel frame	4	10336111004
5	Panel frame	1	10336111005
6	Up clap for panel frame	2	10336111006
7	Air out frame assy	1	10336111007
7,1	Horizontal louver , down	1	10336111008
7,2	Left bush for horizontal louver	1	10336111009
7,3	Horizontal louver , up	1	10336111010
7,4	Louver connecter, middle-left	1	10336111011
7,5	Louver connecter, left	1	10336111012
7,6	Vertical louver, small size	2	10336111013
7,7	Vertical louver, large size	12	10336111014
7,8	Louver holder, left	1	10336111015
7,9	Air out frame	1	10336111016

7.10	Louver holder, middle	1	10336111017
7.11	Stopple	1	10336111018
7.12	Vertical louver, middle size	2	10336111019
7.13	Bush	4	10336111020
7.14	Louver holder, right	1	10336111021
7.15	Louver connecter, right	1	10336111022
7.16	Swing bar for up horizontal louver	1	10336111023
7.17	Connecter for horizontal louver	1	10336111024
7.18	Swing bar for down horizontal louver	1	10336111025
7.19	Louver connecter, middle-right	1	10336111026
8	Evaporator assy	1	10336111027
8,1	Evaporator I	1	10336111028
	Evaporator II	1	10336111029
	Evaporator III	1	10336111030
	Evaporator IV	1	10336111031
	Right holder for evaporator	1	10336111032
8,2	Left holder for evaporator	1	10336111033
8,3	Input pipe for evaporator	1	10336111034
	Output pipe for evaporator	1	10336111035
9	Cross flow fan, assy	1	10336111036
10	Bearing holder	1	10336111037
11	Chassis assy	1	10336111038
11,1	Chassis	1	10336111039
11,2	Left rear cover for chassis	1	10336111040
11,3	Right rear cover for chassis	1	10336111041
12	Installation plate	1	10336111042
13	Corner board for chassis	1	10336111043
14	Base for motor	1	10336111044
15	Fan motor	1	10336111045
16	Cover for motor	1	10336111046
17	Small cover for motor	1	10336111047
18	Waterproof board	1	10336111048
19	Drain hose	1	10336111049
20	Louver motor	1	10336111050
21	Air cleaner	1	10336111051
22	Air cleaner holder	1	10336111052
23	Remote controller	1	10109121207

24	Holder for remote controller	1	10109121208
25	E-parts assy	1	10336121005
25,1	Display board	1	10336121002
25,2	Wire joint, 4p	1	10336111055
25,3	Wire clamp	1	10336111056
25,4	Main control board	1	10336121004
25,5	E-Parts box	1	10336111058
25,6	Transformer	1	50242122817
25,7	Indoor temp sensor	1	10118121242
25,8	Evaporator temp sensor	1	10109121242
26	E-part box cover	1	10336111059
27	Bottom cover for e-box	1	10336111060
28	Clamp for temp sensor	1	10109121231
29	Protector for temp sensor	1	10112121224
30	Copper nut, TLM-D04	1	11324113804
31	Copper nut, TLM-B02	1	10909121013

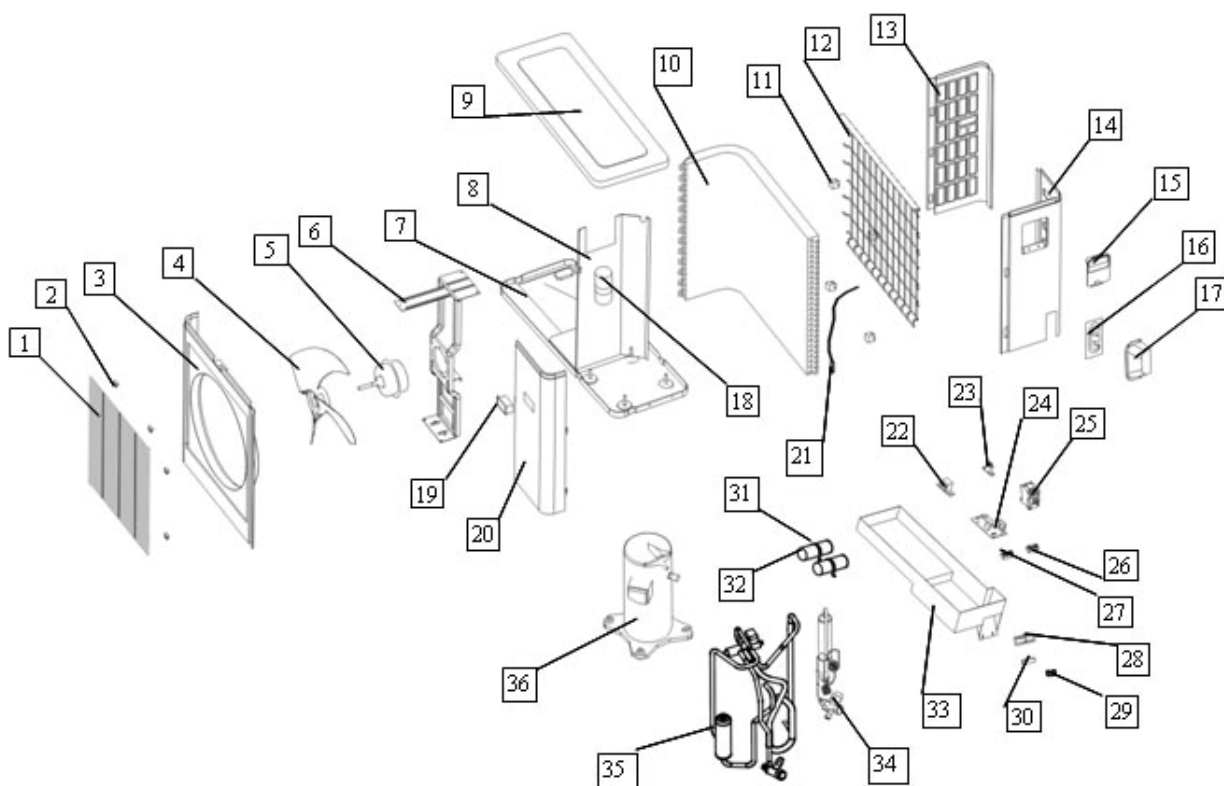

No.	Part Name	Quantity	Sale code
1	Front net	1	10118121801
2	Clamp for front net	8	10112121801
3	Front clapboard	1	11426432801
4	Propeller fan	1	10336111801
5	Fan motor	1	10336111802
6	Holder for fan motor	1	10224121803
7	Chassis	1	11426432808
8	Separating board	1	50224123803
9	Cover	1	10224121804
10	Condenser	1	11324123801
11	Underlay for rear net	4	10118121818
12	Rear net	1	10224121807
13	Left clapboard	1	10224121806
14	Rear right clapboard	1	11426432804
15	Big handle	1	10224121808
16	Installation plate for valves	1	11426432807

17	Water collector	1	10336111804
18	Refrigerant container	1	10224121817
19	Small handle	1	10224121809
20	Front right clapboard	1	10224121825
21	Condenser temp sensor	1	10121121816
22	Transformer	1	10336111806
23	Fan motor capacitor	1	10118121821
24	Main control board	1	10336121804
25	Contactator	1	10336111808
26	Wire joint for multiplexer	2	10121121809
27	Relay	1	10118121238
28	Wire joint	1	10336111809
29	Clamp for wiring	1	10118121823
30	Washer for wire joint	1	10112121817
31	Capacitor clamp	2	10224121816
32	Compressor capacitor	2	10224121815
33	Installation board for E-parts	1	10336111805
34	Liquid pipe valve,assy	1	10336121807
	Liquid pipe valve	1	11426432811
35	4-way valve,assy	1	10336121808
	Gas pipe valve	1	11426432810
	4-way valve	1	10312121852
36	Compressor	1	10336111810
37	Copper nut, TLM-D04	1	11324113804
38	Copper nut, TLM-B02	1	10909121013



Climatic Control Corporation. LLP
 29-30 Margaret Street,
 London W1R 6HH, UK
 Tel /fax: +44 20 7016 0133

Большая библиотека технической документации
<http://splitoff.ru/tehn-doc.html>
каталоги, инструкции, сервисные мануалы, схемы.